



AV AMPLIFIER/AV RECEIVER DSP-AX1/RX-V1

SERVICE MANUAL

IMPORTANT NOTICE

This manual has been provided for the use of authorized YAMAHA Retailers and their service personnel. It has been assumed that basic service procedures inherent to the industry, and more specifically YAMAHA Products, are already known and understood by the users, and have therefore not been restated.

WARNING: Failure to follow appropriate service and safety procedures when servicing this product may result in personal injury, destruction of expensive components, and failure of the product to perform as specified. For these reasons, we advise all YAMAHA product owners that any service required should be performed by an authorized YAMAHA Retailer or the appointed service representative.

IMPORTANT: The presentation or sale of this manual to any individual or firm does not constitute authorization, certification or recognition of any applicable technical capabilities, or establish a principle-agent relationship of any form.

The data provided is believed to be accurate and applicable to the unit(s) indicated on the cover. The research, engineering, and service departments of YAMAHA are continually striving to improve YAMAHA products. Modifications are, therefore, inevitable and specifications are subject to change without notice or obligation to retrofit. Should any discrepancy appear to exist, please contact the distributor's Service Division.

WARNING: Static discharges can destroy expensive components. Discharge any static electricity your body may have accumulated by grounding yourself to the ground buss in the unit (heavy gauge black wires connect to this buss).

IMPORTANT: Turn the unit OFF during disassembly and part replacement. Recheck all work before you apply power to the unit.

CONTENTS

TO SERVICE PERSONNEL	1	TUNER ADJUSTMENTS	34~37
FRONT PANELS	2	IC DATA	38~53
REAR PANELS	3~4	PRINTED CIRCUIT BOARD	54~83
SPECIFICATIONS	5~8	BLOCK DIAGRAM	84~88
INTERNAL VIEW	9	PIN CONNECTION DIAGRAM	89
DISASSEMBLY PROCEDURES	9~10	SCHEMATIC DIAGRAM	90~101
SELF DIAGNOSIS FUNCTION	11~32	PARTS LIST	102~135
AMP ADJUSTMENTS	33	REMOTE CONTROL TRANSMITTER	136~141



このサービスマニュアルは、エコマーク認定の再生紙を使用しています。
This Service Manual uses recycled paper.



■ TO SERVICE PERSONNEL

1. Critical Components Information.
Components having special characteristics are marked \triangle and must be replaced with parts having specifications equal to those originally installed.
2. Leakage Current Measurement (For 120V Models Only).
When service has been completed, it is imperative to verify that all exposed conductive surfaces are properly insulated from supply circuits.
 - Meter impedance should be equivalent to 1500 ohm shunted by 0.15 μ F.
 - Leakage current must not exceed 0.5mA.

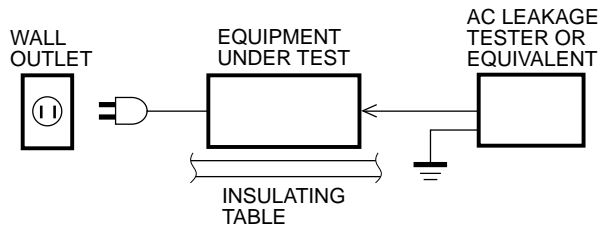

- Be sure to test for leakage with the AC plug in both polarities.



“CAUTION”

“F751 : FOR CONTINUED PROTECTION AGAINST RISK OF FIRE, REPLACE ONLY WITH SAME TYPE 12A, 250V FUSE.”

CAUTION

F751 : REPLACE WITH SAME TYPE 12A, 250V FUSE.

ATTENTION

F751 : UTILISER UN FUSIBLE DE RECHANGE DE MEME TYPE DE 12A, 250V.

WARNING: CHEMICAL CONTENT NOTICE!

The solder used in the production of this product contains LEAD. In addition, other electrical/electronic and/or plastic (where applicable) components may also contain traces of chemicals found by the California Health and Welfare Agency (and possibly other entities) to cause cancer and/or birth defects or other reproductive harm.

DO NOT PLACE SOLDER, ELECTRICAL/ELECTRONIC OR PLASTIC COMPONENTS IN YOUR MOUTH FOR ANY REASON WHATSOEVER!

Avoid prolonged, unprotected contact between solder and your skin! When soldering, do not inhale solder fumes or expose eyes to solder/flux vapor!

If you come in contact with solder or components located inside the enclosure of this product, wash your hands before handling food.

WARNING

Do not change the **IMPEDANCE SELECTOR** switch setting while the power to this unit is on, otherwise this unit may be damaged.

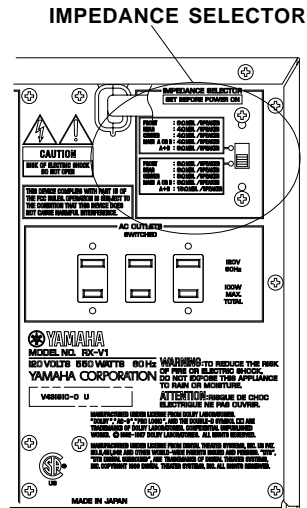

FRONT PANELS

▼ DSP-AX1

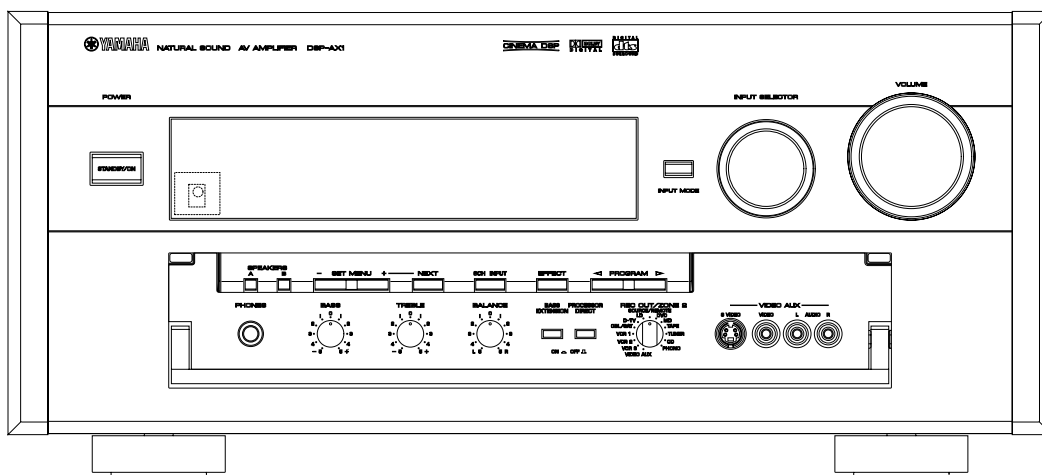

▼ RX-V1

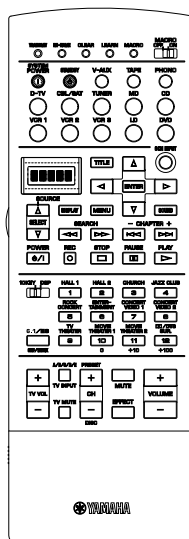
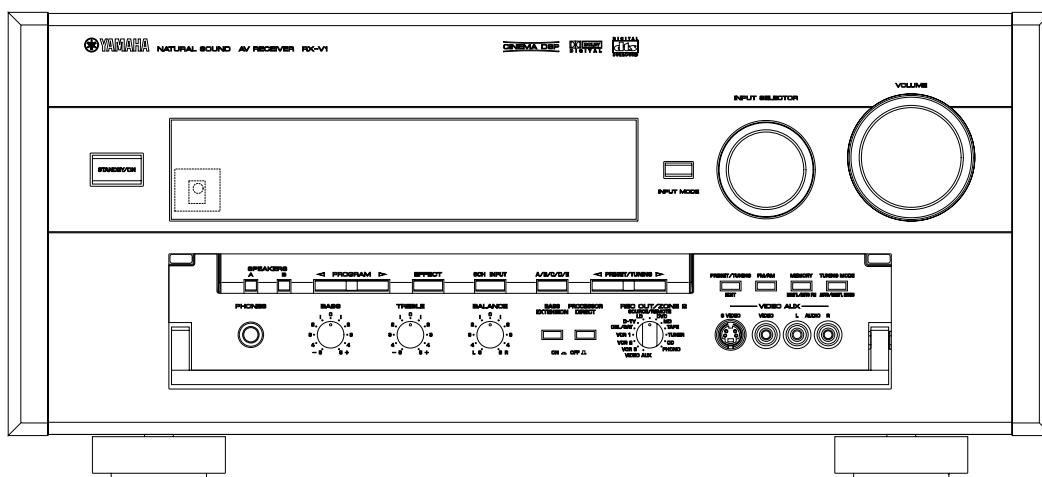

DSP-AX1/RX-V1

■ SPECIFICATIONS

■ AUDIO SECTION

Minimum RMS Output Power per Channel

MAIN, 20Hz to 20kHz, 0.015% THD, 8Ω	110W+110W
CENTER, 20Hz to 20kHz, 0.015% THD, 8Ω	110W
REAR, 20Hz to 20kHz, 0.015% THD, 8Ω	110W+110W
REAR CENTER, 20Hz to 20kHz, 0.015% THD, 8Ω	110W
FRONT, 1kHz, 0.05% THD, 8Ω	35W+35W

Maximum Power per Channel (R, T models only)

MAIN, 1kHz, EIAJ, 10% THD, 8Ω	150W+150W
CENTER, 1kHz, EIAJ, 10% THD, 8Ω	150W
REAR, 1kHz, EIAJ, 10% THD, 8Ω	150W+150W
REAR CENTER, 1kHz, EIAJ, 10% THD, 8Ω	150W
FRONT, 1kHz, EIAJ, 10% THD, 8Ω	45W+45W

Dynamic Power per Channel (U, C, R, T models only)

MAIN, 8/6/4/2Ω	150/180/240/340W
----------------	------------------

Dynamic Headroom (U, C, R, T models only)

8Ω	1.3dB
----	-------

DIN Standard Output Power per Channel (B, G models only)

MAIN, 1kHz, 0.7% THD, 4Ω	180W+180W
CENTER, 1kHz, 0.7% THD, 4Ω	180W
REAR, 1kHz, 0.7% THD, 4Ω	180W+180W
REAR CENTER, 1kHz, 0.7% THD, 4Ω	180W+180W
FRONT, 1kHz, 0.7% THD, 4Ω	60W+60W

IEC Power (B, G models only)

MAIN, 1kHz, 0.015% THD, 8Ω	120W
----------------------------	------

Power Band Width

MAIN, 0.04% THD, 55W/8Ω	10Hz to 50kHz
-------------------------	---------------

Damping Factor

MAIN/CENTER, 20Hz to 20kHz, 8Ω	200 or more
--------------------------------	-------------

Input Sensitivity/Impedance

PHONO MM	2.5mV/47kΩ
CD, etc	150mV/47kΩ
MAIN IN	1V/47kΩ

Maximum Input Signal Level

PHONO MM, 1kHz, 0.05% THD, (Effect on)	100mV
CD, etc, (Effect on)	2.3V

Output Level/Impedance

REC OUT	150mV/600Ω
PRE OUT (MAIN, etc)	1V/1.2kΩ
SUB WOOFER (EFFECT OFF, MAIN SP : SMALL)	
SPLIT	2.0V/1.2kΩ
MONO	4.0V/1.2kΩ

Maximum Voltage Output (20Hz to 20kHz, 1% THD)

PRE OUT (MAIN L/R)	3V
--------------------	----

Headphone Jack Rated Output/Impedance

CD, etc, (40mV, 8Ω)	150mV/100Ω
---------------------	------------

Frequency Response (10Hz to 100kHz)

CD, etc, MAIN L/R	+0/-3.0dB
-------------------	-----------

RIAA Equalization Deviation (20Hz to 20kHz)

PHONO MM	0±0.5dB
----------	---------

Tone Control Characteristics

BASS : Boost/cut	±10dB (50Hz)
Turnover Frequency	350Hz
TREBLE : Boost/cut	±10dB (20kHz)
Turnover Frequency	3.5kHz

Center Graphic Equalizer

Frequency	100/300/1k/3k/10kHz
Boost/cut	±6dB
Q	0.7

Bass Extension

	+6dB (60Hz)
--	-------------

Filter Characteristics

SUB WOOFER OUT : L.P.F.	fc = 90Hz, 24dB/oct.
-------------------------	----------------------

Cinema Equalizer

High	Frequency	1kHz to 12.7kHz
	Boost/cut	-9dB to +6dB
PEQ	Frequency	1kHz to 12.7kHz
	Boost/cut	-9dB to +6dB
	Q	1.85

Total Harmonic Distortion (20Hz to 20kHz)

PHONO MM to REC OUT (1V)	0.01%
CD, etc, to PRE OUT MAIN L/R (1V)	0.005%
MAIN IN to L/C/R SP OUT (55W/8Ω)	0.005%

Signal-to-Noise Ratio (IHF-A-Network)

PHONO MM, Input Shorted 5mV (Effect off)	86dB
CD, etc, Input Shorted (Effect off)	96dB

Residual Noise (IHF-A-Network)

MAIN, SP OUT	150μV
--------------	-------

Channel Separation (Vol. -30dB, Effect off)

PHONO MM, Input Shorted, 1kHz/10kHz	70dB/60dB
CD, etc, Input 5.1kΩ Shorted, 1kHz/10kHz	70dB/60dB

Muting

	-∞
--	----

■ VIDEO SECTION

Video Signal Type

U, C models	NTSC
A, B, G models	PAL
R, T models	NTSC/PAL

Composite Video Signal Level

	1Vp-p/75Ω
--	-----------

S-Video Signal Level

Y	1Vp-p/75Ω
C	0.286Vp-p/75Ω

Component Signal Level

Y	1Vp-p/75Ω
Cb/Cr	0.7V/75Ω

Video Maximum Input Level

	1.5Vp-p
--	---------

Video Signal-to-Noise Ratio

	50dB
--	------

Monitor Output Frequency Response

Composite Video Signal	5Hz~10MHz, -3dB
S-Video Signal	5Hz~10MHz, -3dB
Component Signal	DC~20MHz, -3dB

FM SECTION (RX-V1 only)

Tuning Range
 U, C models 87.5 to 107.9MHz
 A models 87.50 to 108.00MHz

50dB Quieting Sensitivity (IHF, 75 Ω)
 U, C models only
 Mono (1kHz, 100% Mod.) 1.6µV (15.3dBf)
 Stereo (1kHz, 100% Mod.) 23µV (38.5dBf)

Usable Sensitivity (DIN, 75 Ω)
 A model only
 Mono (S/N 26dB) 0.9µV
 Stereo (S/N 46dB) 28µV

Alternate Channel Selectivity (± 400Hz)
 U, C models 75dB

Selectivity (two signals, 40kHz Dev.) (± 300Hz)
 A model 55dB

Signal-to-Noise Ratio
 U, C models
 Mono/Stereo (IHF) 81/75dB
 A model
 Mono/Stereo (DIN-weighted, 40kHz Dev.) 75/69dB

Harmonic Distortion
 Mono/Stereo (1kHz) 0.1/0.2%

Stereo Separation
 1kHz 48dB

Frequency Response
 20Hz to 15kHz 0±1.0dB

Output Level
 U, C models
 FM 100% mod. 1kHz 550mV
 A models
 FM 40kHz Dev. 1kHz 550mV

Antenna Input 75 Ω unbalanced

AM SECTION (RX-V1 only)

Tuning Range
 U, C models 530 to 1,710kHz
 A model 531 to 1,611kHz

Usable Sensitivity 300µV/m

Output Level
 AM 30% mod. 1kHz 150mV

Signal-to-Noise Ratio 52dB

Antenna Loop antenna

Manufactured under license from Dolby Laboratories. "Dolby", "AC-3", "Pro Logic", and the double-D symbol  are trademarks of Dolby Laboratories. © 1992-1997 Dolby Laboratories. All rights reserved.

Manufactured under license from Digital Theater Systems, Inc. US Pat. No. 5,451,942 and other world-wide patents issued and pending. "DTS", "DTS Digital Surround", are trademarks of Digital Theater Systems, Inc. copyright 1996 Digital Theater Systems, inc. All rights reserved.

GENERAL

Power Supply
 U, C models AC 120V, 60Hz
 A model AC 240V, 50Hz
 B, G models AC 230V, 50Hz
 R, T models AC 110/120/220/240V, 50/60Hz

Power Consumption
 U model 550W
 C model 550W/700VA
 A, R, T models 550W

Maximum Power Consumption (R, T models only) .. 770W

AC Outlets
 U, R, T, G models, Switched x 3 100W max (Total)
 C model, Switched x 3 100W max/1.0A max (Total)
 A, B models, Switched x 1 100W max

Dimensions (W x H x D) 471 x 211.5 x 473mm
 (18-9/16" x 8-5/16" x 18-5/8")

Weight 28.0 kg (61 lbs 11oz)

Finish
 RX-V1 Gold color/Black color
 DSP-AX1 Gold color/Black color

Accessories
 RX-V1 only AM loop antenna x 1
 Indoor FM antenna x 1
 DSP-AX1/RX-V1 Remote Control Transmitter x 1
 Battery (size "AA", "R06") x 3

* Specifications subject to change without notice.

- U USA model
- C Canadian model
- A Australian model
- B British model
- G European model
- R General model
- T China model

● DIMENSIONS

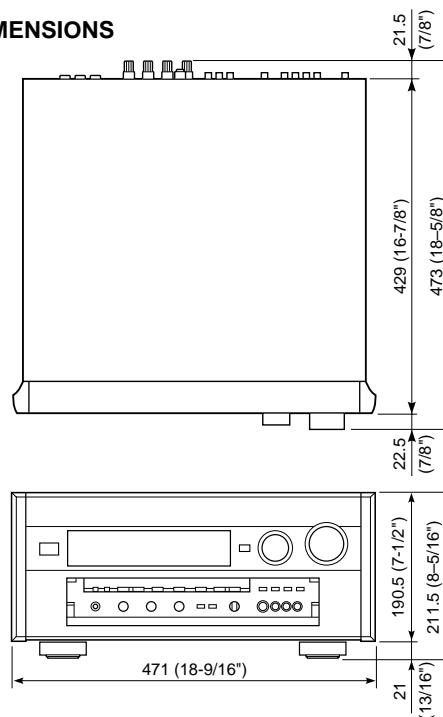

Units : mm (inch)

DSP-AX1/RX-V1

● SET MENU TABLE

No.	SET MENU	PRESET VALUE	SETTING RANGES
1.	SPEAKER SET		
1A	CENTER SPEAKER	LARGE	LARGE/SMALL/NONE
1B	MAIN SPEAKER	LARGE	LARGE/SMALL
1C	REAR L/R SPEAKER	LARGE	LARGE/SMALL/NONE
1D	REAR CT SPEAKER	LARGE	LARGE/SMALL/NONE
1E	LFE/BASS OUT	BOTH	SUBWOOFER/MAIN/BOTH
1F	FRONT EFCT SPEAKER	YES	YES/NONE
1G	MAIN LEVEL	NORMAL	NORMAL/-10dB
2.	LOW FREQ. TEST	TONE : OFF OUTPUT : MAIN L/R FREQUENCY : 88Hz	ON/OFF L/C/R/RS/RC/LS/SW/FRONT 35 — 250Hz
3.	DOLBY DIGITAL SET		
3A	LFE LEVEL	SPEAKER : 0dB HEAD PHONE : 0dB	-20dB — 0dB -20dB — 0dB
3B	DYNAMIC RANGE	SPEAKER : MAX HEAD PHONE : MAX	MAX/STD/MIN MAX/STD/MIN
4.	DTS SET		
4A	LFE LEVEL	SPEAKER : 0dB HEAD PHONE : 0dB	-10dB — +10dB -10dB — +10dB
5.	SPEAKER DELAY TIME	CENTER : 0ms REAR CENTER : 3ms	0ms — 5ms 0ms — 30ms
6.	AUDIO DELAY	0ms	0ms — 99ms
7.	CENTER GRAPHIC EQ.	EACH ch : 0dB	100Hz — 10kHz, -6dB — +6dB
8.	REAR CENTER GRAPHIC EQ.	EACH ch : 0dB	100Hz — 10kHz, -6dB — +6dB
9.	CINEMA EQ.	ALL "OFF"	L, C, R/FRONT EFCT//REAR L,R/REAR CT ON/OFF
9A	L, C, R EQ.	HIGH 12.7kHz, -3dB PEG 12.7kHz, -4dB	HIGH, PGE : 1kHz — 12.7kHz
9B	FRONT EFCT EQ.	HIGH 12.7kHz, 0dB PEG 8kHz, -3dB	GAIN : -9dB — +6dB
9C	REAR L/R EQ.	HIGH 12.7kHz, 0dB PEG 8kHz, -3dB	
9D	REAR CENTER EQ.	HIGH 12.7kHz, 0dB PEG 8kHz, -3dB	
10.	HP TONE CTRL	BASS : 0dB TREBLE : 0dB	-6dB — +3dB -6dB — +3dB
11.	PARAMETER INITIALIZE	OFF	PROGRAM 1 — 12
12.	6.1/ES AUTO	ON	ON/OFF
13.	MEMORY GUARD	OFF	ON/OFF
14.	COMPONENT VIDEO INPUT	[A] : DVD [B] : D-TV [C] : CBL/SAT	DVD, LD, D-TV, CBL/SAT, VCR1, VCR2, VCR3, V-AUX DVD, LD, D-TV, CBL/SAT, VCR1, VCR2, VCR3, V-AUX DVD, LD, D-TV, CBL/SAT, VCR1, VCR2, VCR3, V-AUX
15.	INPUT MODE	D-TV : AUTO CBL/SAT : AUTO VCR1 : AUTO	AUTO/LAST AUTO/LAST AUTO/LAST
16.	INPUT RENAME	LD(Currently selected input)	
17.	DIMMER	0	-4 — 0
18.	ZONE2 SET	ZONE2 OUT : FIX	FIX/VAR

● SUPERIMPOSING

Input LD, etc.		Output		Superimposing
Terminal	Signal	Monitor connection		
S	O	O		O (On screen)
V	O	—		X
S	O	X		X
V	O	—		O (On screen)
S	O	O		O (On screen)
V	X	—		X
S	O	X		X
V	X	—		O (Blue back)
S	X	—		X
V	O	—		X (On screen)
S	X	—		O (Blue back)
V	X	—		O (Blue back)

S : S video signal
V : Composite video signal
O : YES
X : NO
— : NO CARE

Caution: Superimposing function is not usable for component signals.

● PARAMETER TABLE

[SP MODE]																				
Sub-program Name	(P)INITDLY (ms)	(P)ROOM SIZE	(P)LIVENESS	S,DELAY (2ch) ms	S,DELAY (DD/dts) ms	S,INITDLY (DD/dts) ms	S,INITDLY (DD-EX/dts+E5) ms	S,ROOM SIZE (2ch)	S,ROOM SIZE (DD/dts)	S,ROOM SIZE (DD-EX/dts+E5) (2ch)	S,LIVENESS (DD/dts)	S,LIVENESS (DD-EX/dts+E5)	RC,INITDLY (ms)	RC,ROOM SIZE	RC,LIVENESS	REV,TIME \$	REV,DELAY (ms)	REV,LEVEL (%)	EFFECT TRIM (db)	
Europe Hall A	30	1.0	5		10															0
Europe Hall B	30	1.0	5		5															0
Europe Hall C	30	1.0	5		5															0
U.S.A. Hall D	35	1.0	5		5															0
Europe Hall E	30	1.0	5		5															0
Live Concert	45	1.0	5		5															0
Tokyo	40	1.0	3		15												2.5	122	56	0
Frankfurt	95	1.0	3		12												4.0	130	55	0
Restaurant	69	1.0	3		12												4.0	120	52	0
Village Gate	21	1.0	3		5															0
Village Vanguard	26	1.0	3		5												1.6	100	7	0
The Bottom Line	30	1.0	3		5												2.0	160	6	0
Roxy Theatre	15	1.0	5		7												2.0	120	8	0
Warehouse Loft	15	1.0	5		8												2.7	120	4	0
Arena	15	1.0	7		8												2.5	140	4	0
Disco	26	1.0	5		12												2.5	130	10	0
Party	15	1.0	5		12												2.2	120	1	0
Game/Amusement	45	1.0	5		12															0
Pop/Rock	21	1.0	5	25	5	31	31	1.0	1.0	1.0	4	4	15	1.0	5					0
DJ	30	1.0	5	30	5	31	31	1.0	1.0	1.0	4	4	15	1.0	5					0
Classical/Opera	28	1.0	5	30	5	31	31	1.0	1.0	1.0	4	4	15	1.0	5	2.5	142	4	0	
Pavilion	23	1.0	5	30	5	20	20	1.0	1.0	1.0	4	4	15	1.0	5	1.6	100	4	0	
Mono Movie	49	1.0	2		8															0
Variety/Sports	13	1.0	2		30															0
Spectacle	13	1.0	23		15															0
Sci-Fi	16	1.0	2		20															0
Adventure	15	1.0	12		15															0
General	15	1.0	20		15															0
Normal	20	1.0	5		20															0
Enhanced	20	1.0	5		20															0

[HP MODE]																				
Sub-program Name	(P)INITDLY (ms)	(P)ROOM SIZE	(P)LIVENESS	S,DELAY (2ch) ms	S,DELAY (DD/dts) ms	S,INITDLY (DD/dts) ms	S,INITDLY (DD-EX/dts+E5) ms	S,ROOM SIZE (2ch)	S,ROOM SIZE (DD/dts)	S,ROOM SIZE (DD-EX/dts+E5) (2ch)	S,LIVENESS (DD/dts)	S,LIVENESS (DD-EX/dts+E5)	RC,INITDLY (ms)	RC,ROOM SIZE	RC,LIVENESS	REV,TIME \$	REV,DELAY (ms)	REV,LEVEL (%)	EFFECT TRIM (db)	
Europe Hall A	30	1.0	5		10															
Europe Hall B	32	1.0	5		5															
Europe Hall C	30	1.0	5		5															
U.S.A. Hall D	35	1.0	5		5															
Europe Hall E	30	1.0	5		5															
Live Concert	45	1.0	5		5															
Tokyo	40	1.0	3		15												2.5	122	56	0
Frankfurt	95	1.0	3		15												4.0	117	55	0
Royalton	69	1.0	3		15												4.0	120	52	0
Village Gate	21	1.0	3		5															
Village Vanguard	26	1.0	3		5															
The Bottom Line	30	1.0	5		5															
Roxy Theatre	15	1.0	5		7												1.6	100	7	0
Warehouse Loft	15	1.0	5		8												2.0	160	6	0
Arena	28	1.0	7		8												2.0	120	8	0
Disco	26	1.0	5		12												2.7	120	4	0
Party	15	1.0	5		12												2.5	140	4	0
Game/Amusement	45	1.0	5		12												2.5	110	10	0
Pop/Rock	21	1.0	5	25	5	31	31	1.0	1.0	1.0	4	4	15	1.0	5		2.2	120	2	0
DJ	30	1.0	5	30	5	30	30	1.0	1.0	1.0	4	4	15	1.0	5					0
Classical/Opera	28	1.0	5	30	5	18	18	1.0	1.0	1.0	4	4	15	1.0	5	2.5	142	4	0	
Pavilion	23	1.0	5	30	5	20	20	1.0	1.0	1.0	4	4	15	1.0	5	1.6	100	4	0	
Mono Movie	45	1.0	2		8															0
Variety/Sports	10	1.0	8		30															0
Spectacle	13	1.0	23		8															0
Sci-Fi	21	1.0	2		20															0
Adventure	16	1.0	12		8															0
General	15	1.0	20		15															0
Normal	20	1.0	5		20															0
Enhanced	20	1.0	5		20															0

INTERNAL VIEW

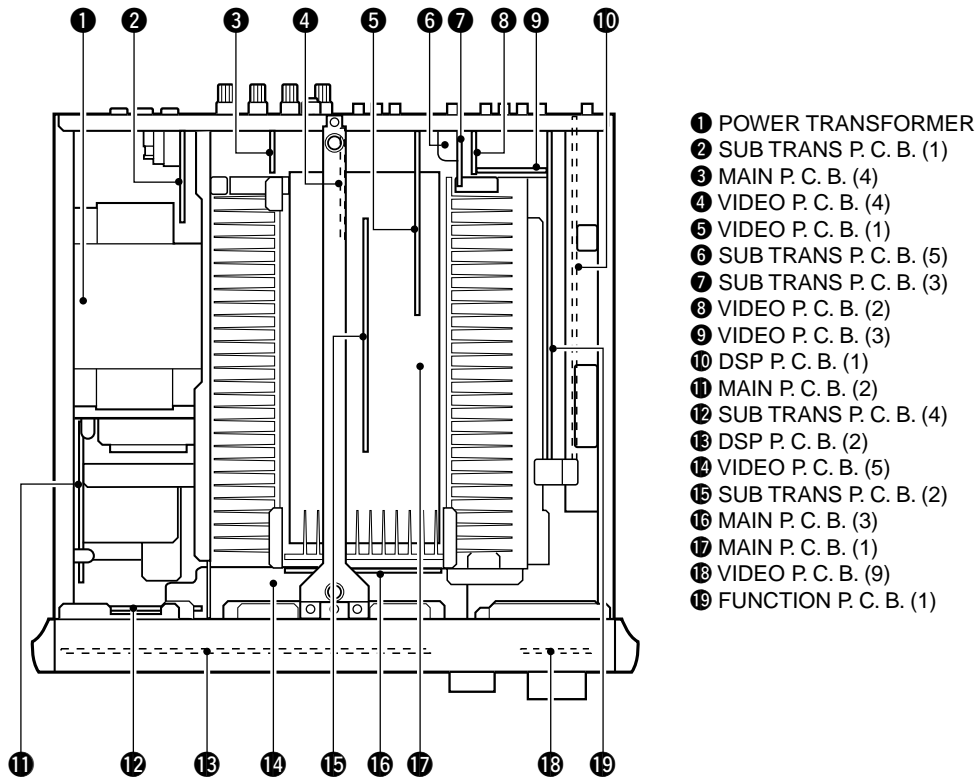

DISASSEMBLY PROCEDURES (Remove parts in the order as numbered.)

1. Removal of Top Cover

- Remove 8 screws (1) and then slide the Side Panel to remove it in Fig. 1.
- Remove 2 screws (2) and 2 screws (3) and then remove the Top Cover in Fig. 1.

2. Removal of Bottom Cover

- Remove 12 screws (4) and then remove the Bottom Cover in Fig. 1.

3. Removal of Front Panel

- Remove 2 knobs in Fig. 1.
- Remove 4 screws (5) and then slide the Panel/Side forward to remove it in Fig. 1.
- Remove 4 screws (6) and then remove the Front Panel in Fig. 1.

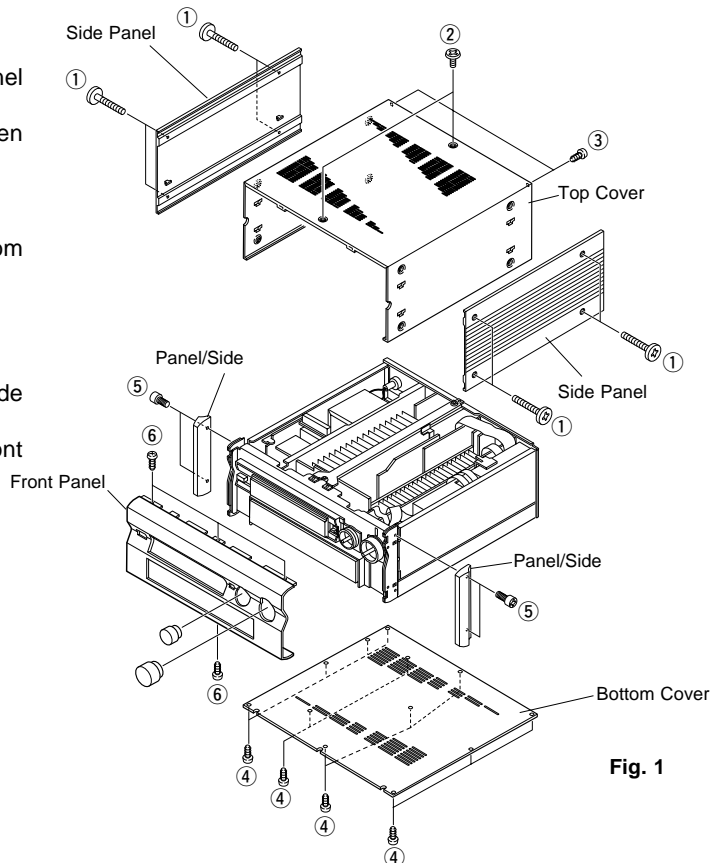

Fig. 1

4. Removal of DSP P.C.B. (1)

- a. Remove 2 screws (⑦) and remove the right Plate Side in Fig. 2.
- b. Remove 15 screws (⑧) and remove the right Upper Frame in Fig. 2.

Note :
 1. When the rear panel has been removed, the ground wire of the input/output pin jack becomes loose. Connect it to the chassis by using a lead wire.

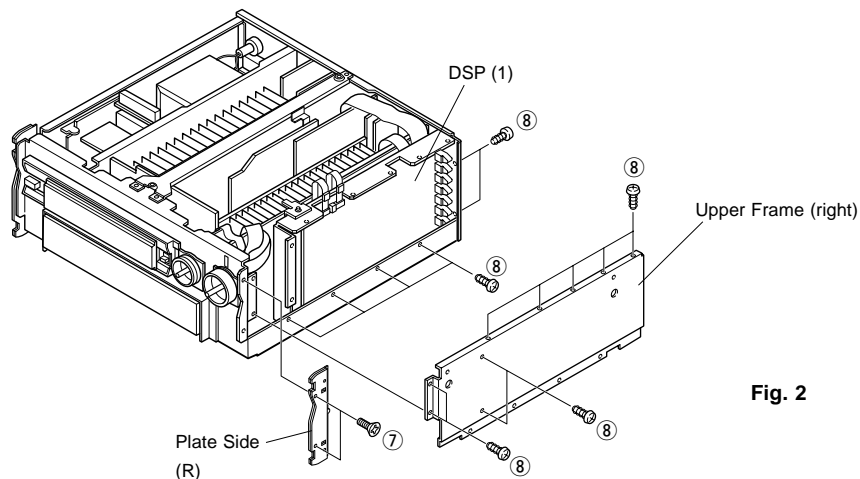

Fig. 2

5. Removal of Main P.C.B. (2)

- a. Remove 2 screws (⑨) and remove the left Plate Side in Fig. 3.
- a. Remove 6 screws (⑩) and then remove the left Side Frame in Fig. 3.

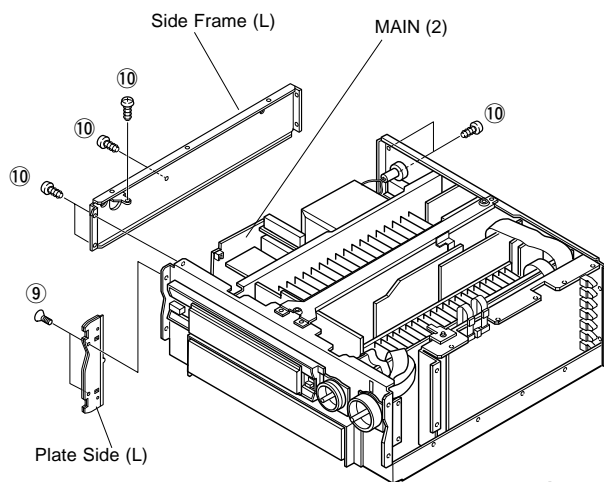

Fig. 3

6. Removal of Main P.C.B. (3)

- a. Remove 4 screws (⑪) and remove the center Upper Frame in Fig. 4.
- b. Remove 6 screws (⑫) and then take up the Sub Chassis in Fig. 4.

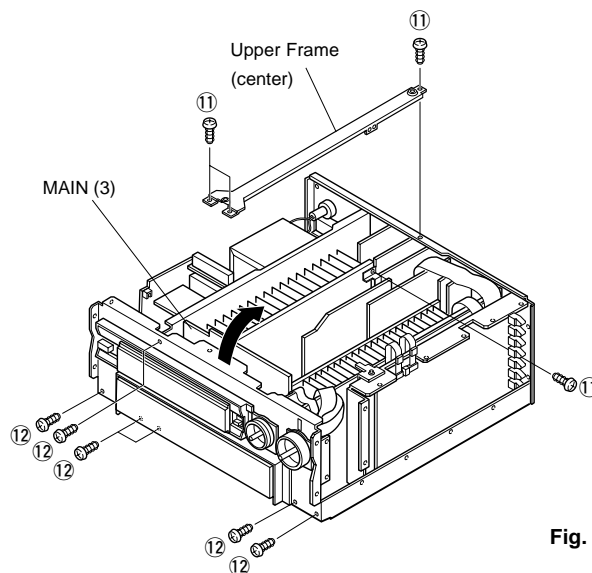

Fig. 4

DSP-AX1/RX-V1

■ SELF DIAGNOSIS FUNCTION

This product has a built-in self diagnosis function (DIAG) to facilitate inspection, measurement and determination of a faulty item, if any. There are 14 DIAG menu items each of which has sub-menu items.

Listed in the table below are menu items and sub-menu items.

No.	DIAG menu	Sub-menu	Remote control code (key)
1	DSP THROUGH	1. ANALOG BYPASS	7A---90 (PRG 9)
		2. DSP 0dB	7A---91 (PRG 10)
		3. DSP FULL BIT	7A---92 (PRG 11)
2	DECODER THROUGH	1. YSS918/908	7A---93 (PRG 12)
		2. DSP FULL BIT	7A---10 (TUNER PRESET +)
3	RAM THROUGH	1. 2ch/MULTI	7A---11 (TUNER PRESET -)
		2. DSP FULL BIT	7A---12 (TUNER A/B/C/D/E)
4	PRO LOGIC	1. YSS918	7A---9C (SET DOWN)
		2. YSS908	7A---9D (SET UP)
		3. EFFECT OFF	7A---9E (SET INC)
5	BYPASS	1. DECODER	7A---9F (SET DEC)
		2. DSP	-----
6	SPEAKERS SET	1. MAIN:SMALL 0dB	7A---88 (PRG 1)
		2. MAIN:LARGE -10	7A---89 (PRG 2)
		3. CENTER:NONE	7A---8A (PRG 3)
		4. LFE/BASS:MAIN	7A---8B (PRG 4)
		5. FRONT MIX:5ch	7A---8C (PRG 5)
		6. CENTER:SMALL	7A---8D (PRG 6)
		7. REAR:SMALL	7A---8E (PRG 7)
7	DISPLAY CHECK	1. EFFECT OFF (initial screen)	7A---8E (PRG 8)
		2. DISPLAY OFF	-----
		3. DISPLAY ALL	-----
		4. DISPLAY DIMMER (50%)	-----
		5. CHECKED PATTERN	-----
8	MANUAL TEST	1. ALL	7A---00 (TAPE PLAY)
		2. MAIN L	7A---01 (TAPE RW)
		3. CENTER	7A---02 (TAPE FW)
		4. MAIN R	7A---03 (TAPE STOP)
		5. REAR R	7A---04 (TAPE PAUSE)
		6. REAR C	7A---05 (TAPE MUTE)
		7. REAR L	7A---06 (TAPE A/B)
		8. FRONT L	7A---07 (TAPE DIR A)
		9. FRONT R	7A---08 (CD PLAY)
		10. LFE	7A---09 (CD STOP)
9	RS-232C	1. TX DATA	-----
		2. HARD FLOW	-----
10	PRESET	1. INHIBIT (memory initialization inhibited)	-----
		2. RESERVED (memory initialized)	-----
11	FAN/AD	1. FAN HISTORY	-----
		2. KY0, KY1(PANEL KEY)	-----
		3. MTR, THM, PRD, PRV	7A---56 (EFFECT)
12	IF STATUS (0 – 18)	1. SCPU	-----
		2. VER	-----
		3. SUM	-----
		4. CHS1	-----
		5. CHS2	-----
		6. CHS3	-----
		7. CHS4	-----
		8. CHS5	-----
		9. BSI1	-----
		10. BSI2	-----

No.	DIAG menu	Sub-menu	Remote control code (key)
12	IF STATUS	11. BSI3	-----
		12. BSI4	-----
		13. BSID	-----
		14. DIR5	-----
		15. Y918	-----
		16. Y908	-----
		17. DSP6	-----
		18. RAM1	-----
		19. RAM2	-----
13	DSP RAM CHECK	#1, #2 (DSP RAM check)	-----
14	SUM/VER/PORT	1. M, S (main/sub checksum)	-----
		2. M, S (main/sub version)	-----
		3. PORT (setting confirmation of function setting port)	-----
		4. REC-OUT (confirmation of REC OUT port)	-----

● **Starting DIAG**

For DSP-AX1:

Press the “POWER” (STANDBY/ON) key of the main unit while pressing the “SET MENU+” key and the “NEXT” key located in the sealing panel of the main unit, and DIAG will be activated.

For RX-V1:

Press the “POWER” (STANDBY/ON) key of the main unit while pressing the “PROGRAM ▷” key and the “EFFECT” key located in the sealing panel of the main unit, and DIAG will be activated.

● **Starting DIAG in the protection cancel mode**

If the power supply, amplifier protection function is activated and hinders the trouble diagnosis, cancel the protection function as described below, and it will be possible to enter the DIAG mode. (The protection function other than the excess current detect function will be cancelled.)

For DSP-AX1:

Press the “POWER” (STANDBY/ON) key while pressing the “SET MENU+” key and the “NEXT” key. At this time, keep pressing the “SET MENU+” key and the “NEXT” for 3 seconds or longer.

For RX-V1:

Press the “POWER” (STANDBY/ON) key while pressing the “PROGRAM ▷” key and the “EFFECT” key. At this time, keep pressing the “PROGRAM ▷” key and the “EFFECT” key for 3 seconds or longer.

In this mode, “  ” in the FL display of the main unit flashes.

CAUTION!

Using this product with the protection function cancelled may cause damage to itself. Use special care for this point when using this mode.

● **Canceling DIAG**

Turn off the power by pressing the “POWER” (STANDBY/ON) key of the main unit or the “STANDBY” key of the remote control unit.

CAUTION: When canceling this function, check that DIAG menu No.10 PRESET (memory initialization inhibited/reserved) has been set. (To keep the user memory, be sure to select “INHIBIT” (initialization inhibited) from the No.10 PRESET menu before canceling the DIAG function.)

● Display at the start of DIAG

The diagnostic menu appears on the monitor screen. (It remains on display until it is canceled.)

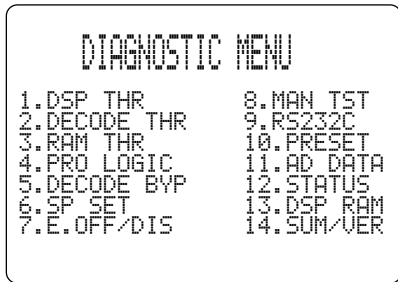

On the FL display of the main unit, an opening message (including the version and the history of protection function) appears for a few seconds followed by the diagnostic menu display of 1 DSP THROUGH: ANALOG BYPS.

Opening message

When there is no history of protection function (*1)

Version of the main/sub microprocessor (1 alphabet)

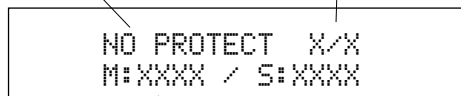

Checksum of the main microprocessor

Checksum of the sub microprocessor

Checksum (4 figures consisting of alphabets and numbers)

The checksum is obtained by adding 4M bits per 1 octo of the entire program code and expressing the result as a 4-figure hexadecimal data. (0xff is added for the area where no code has been entered and for the area other than ROM code.)

DIAG menu display

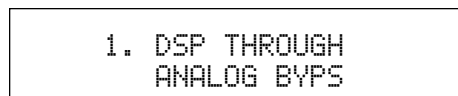

(*1) If the history of the protection function has been recorded, the type of the protection function and the voltage value recorded last are displayed.

In the case where the protection function works after DIAG has been started and the power is turned off ;
 When the protection function (*2) works, the history of the protection function appears on display and the power turns off. Repair the faulty parts according to the displayed history.

(*2) When an excess current or any other faulty condition is found with the power source, DC, etc., the protection function forces the power to turn off.

```
I PROTECT X/X
M:XXXX / S:XXXX
```

I PROTECTION display

(When the power is turned on without an abnormality corrected, the protection function works the moment the power relay is turned on to shut off the power supply.)

Cause: There is an abnormal current flow to the power amplifier.
Supplementary information: If I PROTECTION function has worked after SP relay ON, a warning message "CHECK SP WIRES" appears the next time the power is turned on. This indicates that some trouble exists after the SP terminal, such as a short-circuit of the speaker cable.

```
PS PRT :000 X/X
M:XXXX / S:XXXX
```

PS PRT display

(When the power is turned on without an abnormality corrected, the protection function works about 1 second later to shut off the power supply. Display may not be provided, if there is an abnormality with the power supply for the display.)

Cause: There is an abnormality in the power supply section (voltage).
Supplementary information: As the power from following sources is detected, it is possible to determine where an abnormality exists.

- Transformer secondary winding
- VI X 2(CB704), YE x 2(CB482)
- U, C only : GY x 2(CB481)
- Stabilizing power source
- ±12, ±5V, +5D1, +5D2, +3.3, VP

```
DC PRT :000 X/X
M:XXXX / S:XXXX
```

DC PRT display

(When the power is turned on without an abnormality corrected, the protection function works about 3 seconds later to shut off the power supply.)

Cause: A DC output from the power amplifier is detected in the bad channel.

```
TMP PRT:000 X/X
M:XXXX / S:XXXX
```

TMP PRT display

(When the power is turned on without an abnormality corrected, the protection function works about 3 seconds later to shut off the power supply.)

Cause: The temperature of the heat sinks in the power amplifier is detected. When the temperature rises and an abnormality is detected, the power turns off.

Besides the above possible causes, the cause may exist in the disconnected connector or around CPU. PS PRT, DC PRT and TMP PRT displays include the abnormal A/D value in % (voltage value obtained by considering 5V as 100%). Concerning this value, refer to DIAG menu No.11 FAN/AD described on page 28.

● History of protection function

When the protection function has worked, its history is stored in memory with a backup. Even when no abnormality is noted while the unit is being serviced, an abnormality which has occurred previously can be defined as long as the backup data has been stored.

The protection history is cleared when DIAG is canceled by selecting "RESERVED" (memory initialization) from the setting items of the DIAG menu No.10 PRESET or when the backup data is erased.

● **Operation procedure of DIAG menu and SUB-MENU**

There are No.1 to No.14 MENU items and some SUB-MENU items as well.

DIAG menu selection

DSP-AX1 Main unit: PROGRAM ▷(forward)/◁(reverse) key
 RX-V1 Main unit: PRESET TUNING + (forward)/-(reverse) key

SUB-MENU selection

DSP-AX1 Main unit: SET MENU + (forward)/-(reverse) key
 RX-V1 Main unit: PROGRAM ▷(forward)/◁(reverse) key
 Remote control unit: Only the remote control key in the Menu List can directly call a sub menu.

● **Functions during DIAG being set**

In addition to the DIAG menu, functions as listed below are available.

- Input selection (including ZONE2), 6CH input
- REC OUT switching
- ZONE2 input, volume
- Front/Center/Rear/Sub-woofer level adjustment
- Muting
- Speaker A/B
- Power on/off operation
- Master volume

It is possible to set to the following volume values using the remote control unit only during DIAG being set.

Volume value (dB)	Remove control code (key)
0	7A---E0 (PAGE A)
-21	7A---E1 (PAGE B)
-35	7A---E2 (PAGE C)
MUTE	7A---E3 (PAGE D)

- Functions related to the tuner and the set menu are not available.
- It is possible to confirm Menu No.12 IF STATUS while keeping the signal process (operation status) of each DIAG menu by using the INPUT MODE key of the main unit.

● **Initial settings used to start DIAG function**

Following initial settings are used when starting the DIAG function.
 When the DIAG function is canceled, the settings before starting DIAG will be restored.

- Input, ZONE2 input: LD (6CH INPUT OFF)
- Master volume: -40dB
- ZONE2 volume: -6dB
- Front/Center/Rear/Sub-woofer level: 0dB
- Audio mute: OFF
- Speaker A/B: ON

Details of DIAG menu

In each menu, "SPEAKERS" is always set to "LARGE", D-RANGE to "MAX", LFE LEVEL to 0dB (-10dB when DOLBY DIGITAL is used) and CENTER DELAY to 0ms unless otherwise specified.

1. DSP THROUGH

There are 3 sub menu items (ANALOG BYPS, DSP 0dB, FULL BIT).

1. DSP THROUGH
ANALOG BYPS

1. DSP THROUGH
DSP 0dB

1. DSP THROUGH
FULL BIT

ANALOG BYPS [Remote control code: 7A—90(PRG 9)]

- The input mode is fixed to use the analog (A/D) system.
- The L/R signal is output through the analog bypass without using the DSP section.
- C/RC, RL/RR, FL/FR, SWL/SWR signals are output using L/R through via DSP.

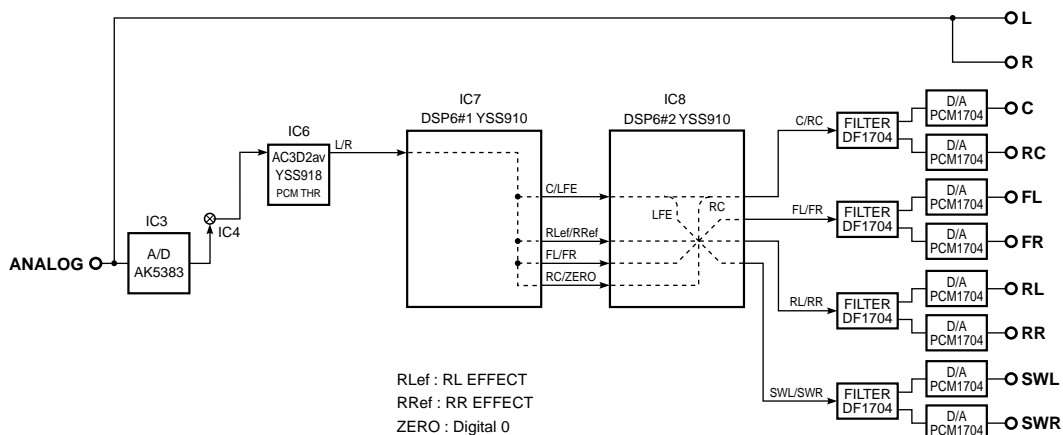

AC3D2av outputs signals using 2ch though. (L/F)

- DSP#1 outputs the L/R input signals to C/LFE (SD611), RLef/RRef (SD613), FL/FR (SD614), RC (SD615, L only).
- DSP#2 outputs the output signals from DSP#1 to C/RC (SD621), RL/RR (SD623), FL/FR (SD622), SWL/SWR (SD624).

Note: (SDxxx) represents a terminal name of DSP#1 and DSP#2.

Reference

CD ANALOG IN	: -20dBV, Both ch
VOLUME	: MAX
PRE OUT	
MAIN L (1kHz)	: -3.7dBV
MAIN R (1kHz)	: -3.7dBV
CENTER (1kHz)	: -3.2dBV
REAR CENTER (1kHz)	: -3.4dBV
FRONT L (1kHz)	: -3.5dBV
FRONT R (1kHz)	: -3.4dBV
REAR L (1kHz)	: -3.4dBV
REAR R (1kHz)	: -3.3dBV
SW L (50Hz)	: -3.3dBV
SW R (50Hz)	: -3.3dBV
SW MONO (50Hz)	: +2.7dBV

DSP-AX1/RX-V1

DSP 0dB [Remote control code: 7A—91 (PRG 10)]

The input signal is automatically identified and switched in the priority order of dts > DOLBY DIGITAL > PCM AUDIO > Analog (A/D) according to the signal detection.

The L/R, C/LFE, FL/FR, RL/RR, RC signals are output through DSP.

(In the case of 2-ch source)

- AC3D2av outputs signals using 2ch though. (L/R)
- DSP6#1 outputs the L/R input signals to L/R (SD610), C/LFE (SD611), RLef/RRef (SD613), FL/FR (SD614), RC (SD615, L only).
- DSP6#2 outputs the output signals of DSP6#1 to L/R (SD620), C/RC (SD621), RL/RR (SD623), FL/FR (SD622), SWL/SWR (SD624).

Reference	CD ANALOG IN	: -20dBV, Both ch	
	VOLUME	: MAX	
	PRE OUT		
	MAIN L (1kHz)	: -3.5dBV	REAR L (1kHz)
	MAIN R (1kHz)	: -3.5dBV	REAR R (1kHz)
	CENTER (1kHz)	: -3.2dBV	SW L (50Hz)
	REAR CENTER (1kHz)	: -3.4dBV	SW R (50Hz)
	FRONT L (1kHz)	: -3.5dBV	SW MONO (50Hz)
	FRONT R (1kHz)	: -3.4dBV	: +2.7dBV

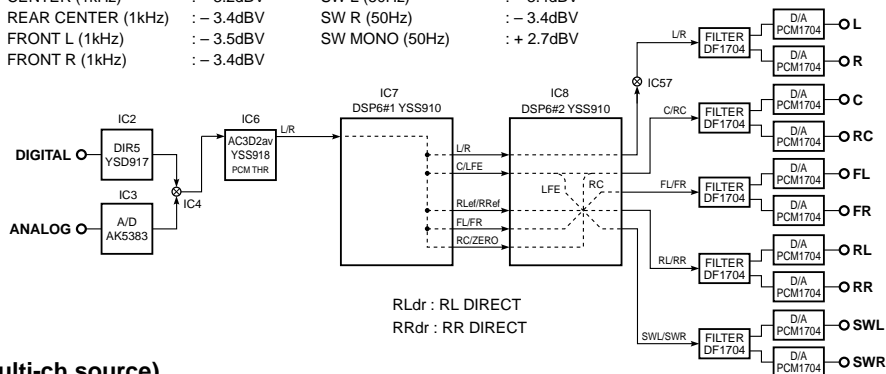

(In the case of multi-ch source)

- AC3D2av outputs signals using DOLBY DIGITAL/dts decode operation.
- DSP6#1 outputs the L/R input signals to L/R (SD610), RC (SD615, L only), C/LFE to C/LFE (SD611), LSt/RSt to RLdr/RRdr (SD612), FL/FR (SD614) respectively.
- DSP6#2 outputs the output signals of DSP6#1 to L/R (SD620), C/RC (SD621), RL/RR (SD623), FL/FR (SD622), SWL/SWR (SD624).

Reference	CD DIGITAL IN	: 1kHz, -20dBV	
	VOLUME	: MAX	
	PRE OUT		
	MAIN L	: +4.2dBV	FRONT L
	MAIN R	: +4.2dBV	FRONT R
	CENTER	: +4.5dBV	REAR L
	REAR CENTER	: +4.2dBV	REAR R
			: +4.3dBV

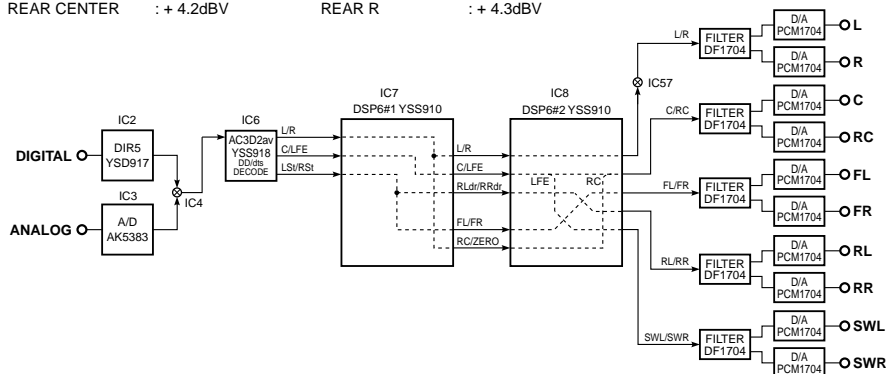

FULL BIT [Remote control code: 7A—92 (PRG11)]

The head margin is unused and the digital data is output in full bit.

The same applies as "DSP 0dB" except that the digital data is output in full bit at D/A.

Reference	CD ANALOG IN	: -30dBV, Both ch	
	VOLUME	: MAX	
	PRE OUT		
	MAIN L (1kHz)	: -7.5dBV	REAR L (1kHz)
	MAIN R (1kHz)	: -7.5dBV	REAR R (1kHz)
	CENTER (1kHz)	: -7.2dBV	SW L (50Hz)
	REAR CENTER (1kHz)	: -7.5dBV	SW R (50Hz)
	FRONT L (1kHz)	: -7.5dBV	SW MONO (50Hz)
	FRONT R (1kHz)	: -7.5dBV	: +13.5dBV

2. DECODER THR.

The input signal is automatically identified and switched in the priority order of dts > DOLBY DIGITAL > PCM AUDIO > Analog (A/D). There are two sub-menu items (YSS918/908, FULL BIT). This menu is used to check the signal passage of the decoder LSI (YSS918, YSS908).



YSS918/908 [Remote control code: 7A—93 (PRG12)]

(In the case of 2-ch source)

- AC3D2av outputs L/R input signals from L/R (SDA200, Lt/Rt (SDA21) and C/LFE (SDA22).
- AC3D2av outputs the Lt/Rt output signals of AC3D2av from LS/RS (SDA10).
- DSP6#1 outputs the L/R input signals to L/R (SD610) and RC (SD615, L only), C/LFE (SD611) input signals to C/LFE (SD611), Lt/Rt input signals to FL/FR (SD614) and LS/RS input signals to RLdr/RRdr (SD612) respectively.
- DSP6#2 outputs the output signals of DSP6#1 to L/R (SD620), C/RC (SD621), RL/RR (SD623), FL/FR (SD622) and SWL/SWR (SD624).

Note: (SDAxx) represents the terminal name of AC3Dav and AC3D2av.
(SDxxx) represents the terminal name of DSP6#1 and DSP6#2.

Reference	CD ANALOG IN	: -20dBV, Both ch		
	VOLUME	: MAX		
	PRE OUT			
	MAIN L (1kHz)	: -3.5dBV	REAR L (1kHz)	: -3.4dBV
	MAIN R (1kHz)	: -3.4dBV	REAR R (1kHz)	: -3.3dBV
	CENTER (1kHz)	: -3.2dBV	SW L (50Hz)	: -3.3dBV
	REAR CENTER (1kHz)	: -3.4dBV	SW R (50Hz)	: -3.3dBV
	FRONT L (1kHz)	: -3.5dBV	SW MONO (50Hz)	: +2.7dBV
	FRONT R (1kHz)	: -3.4dBV		

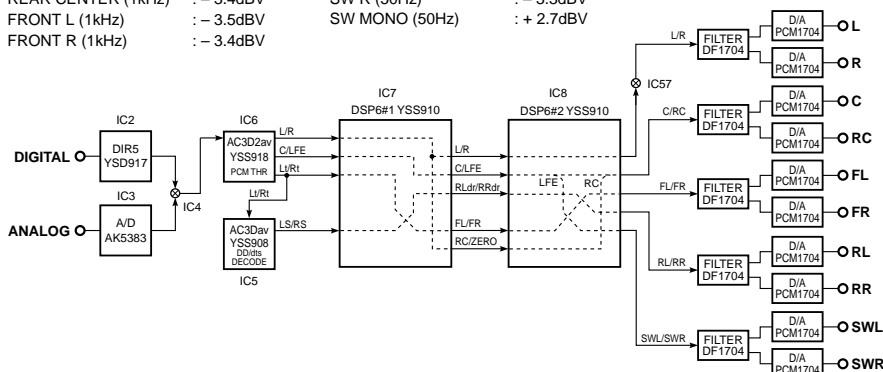

(In the case of multi-ch source)

- AC3D2av outputs dts or DOLBY DIGITAL encoded input signals from Lt/Rt (SDA21) without decoding.
- AC3Dav processes Lt/Rt output signals of AC3D2av by dts or DOLBY DIGITAL decoding and outputs them to LS/RS (SDA10) and RC (SDA12, L only) through 3/0 down-mixing.
- DSP6#1 outputs the LS/RS input signals to RLdr/RRdr (SD612) and the RC (L only) input signals to RC (SD615, L only).
- DSP6#2 outputs the output signals of DSP6#1 to RC (SD621, R only) and RL/RR (SD623).

Reference	CD DIGITAL IN	: 1kHz, -20dBV		
	VOLUME	: MAX		
	PRE OUT			
	MAIN L	: +4.5dBV	FRONT L	: +4.6dBV
	MAIN R	: +4.6dBV	FRONT R	: +4.6dBV
	CENTER	: +4.9dBV	REAR L	: +4.7dBV
	REAR CENTER	: +4.6dBV	REAR R	: +4.7dBV

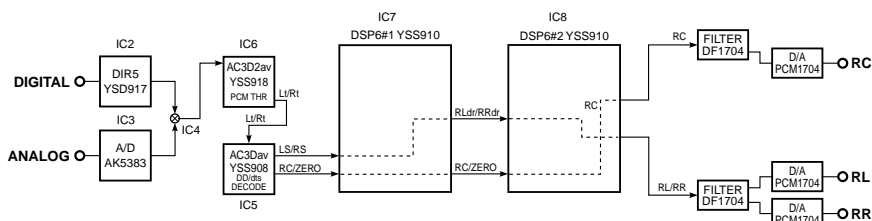

DSP-AX1/RX-V1

FULL BIT [Remote control code: 7A—10 (TUNER PRESET +)]

The head margin is unused and the digital data is output in full bit.

The same applies as YSS918/908 except that the digital data is output in full bit at D/A.

Reference	CD ANALOG IN	: -30dBV, Both ch	
	VOLUME	: MAX	
	PRE OUT		
	MAIN L (1kHz)	: -7.5dBV	REAR L (1kHz) : -1.4dBV
	MAIN R (1kHz)	: -7.5dBV	REAR R (1kHz) : -1.3dBV
	CENTER (1kHz)	: -7.2dBV	SW L (50Hz) : +7.6dBV
	REAR CENTER (1kHz)	: -7.5dBV	SW R (50Hz) : +7.5dBV
	FRONT L (1kHz)	: -7.5dBV	SW MONO (50Hz) : +13.7dBV
	FRONT R (1kHz)	: -7.4dBV	

3. RAM THROUGH

The input data is automatically identified and switched in the priority order of dts > DOLBY DIGITAL > PCM AUDIO > Analog (A/D) according to the signal detection.

The main L/R uses the analog through method when analog signals are input and the DSP through method when digital signals are input.

There are two sub-menu items (2ch/MULTI, FULL BIT).

3. RAM THROUGH
2ch/MULTI

3. RAM THROUGH
FULL BIT

2ch/MULTI [Remote control code: 7A—11 (TUNER PRESET -)]

(In the case of 2-ch source)

- AC3D2av outputs signals using 2ch though. (L/R)
- DSP6#1 outputs the L/R input signals to L/R (SD610), C/LFE (SD611) and RC (SD615, L only). Also, it outputs L/2 + R/2 to RLeF/RReF (SD613) and FL/FR (SD614) through the external RAM.
- DSP6#2 outputs the output signals of DSP6#1 to L/R (SD620), RL/RR (SD623), FL/FR (SD622), SWL/SWR (SD624). Also, it outputs C/RC to C/RC (SD621) through the external RAM.

Reference	CD ANALOG IN	: -20dBV, Both ch	
	VOLUME	: MAX	
	PRE OUT		
	MAIN L (1kHz)	: -3.5dBV	REAR L (1kHz) : -3.4dBV
	MAIN R (1kHz)	: -3.4dBV	REAR R (1kHz) : -3.3dBV
	CENTER (1kHz)	: -3.2dBV	SW L (50Hz) : -3.3dBV
	REAR CENTER (1kHz)	: -3.4dBV	SW R (50Hz) : -3.3dBV
	FRONT L (1kHz)	: -3.4dBV	SW MONO (50Hz) : +2.7dBV
	FRONT R (1kHz)	: -3.4dBV	

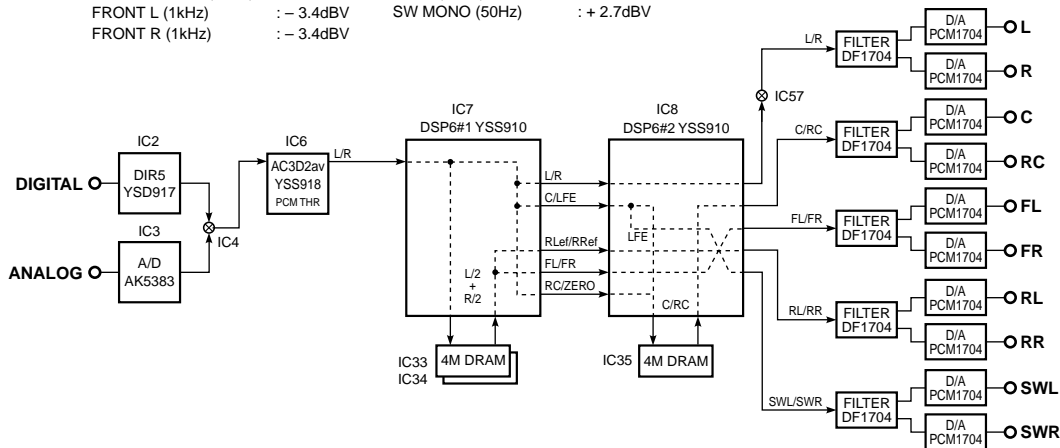

DSP-AX1/RX-V1

(In the case of multi-ch source)

- AC3D2av outputs signals using DOLBY DIGITAL/dts decode operation.
- DSP6#1 outputs the L/R signals to L/R (SD610), RC (SD615, L only), C/LFE to C/LFE (SD611), LSt/ RSt to RLdr/RRdr (SD612). Also, it outputs L/2 + R/2 to FL/FR (SD614) through the external RAM.
- DSP6#2 outputs the output signals of DSP6#1 to L/R (SD620), FL/FR (SD622), SWL/SWR (SD624). Also, it outputs C/RC and RL/RR to C/RC (SD621) and RL/RR (SD623) through the external RAM.

Reference	CD DIGITAL IN	: 1kHz, -20dBV		
	VOLUME	: MAX		
	PRE OUT			
	MAIN L	: +4.2dBV	REAR L	: +4.3dBV
	MAIN R	: +4.2dBV	REAR R	: +4.3dBV
	CENTER	: +4.5dBV		
	REAR CENTER	: +4.2dBV		
	FRONT L	: +4.2dBV		
	FRONT R	: +4.3dBV		

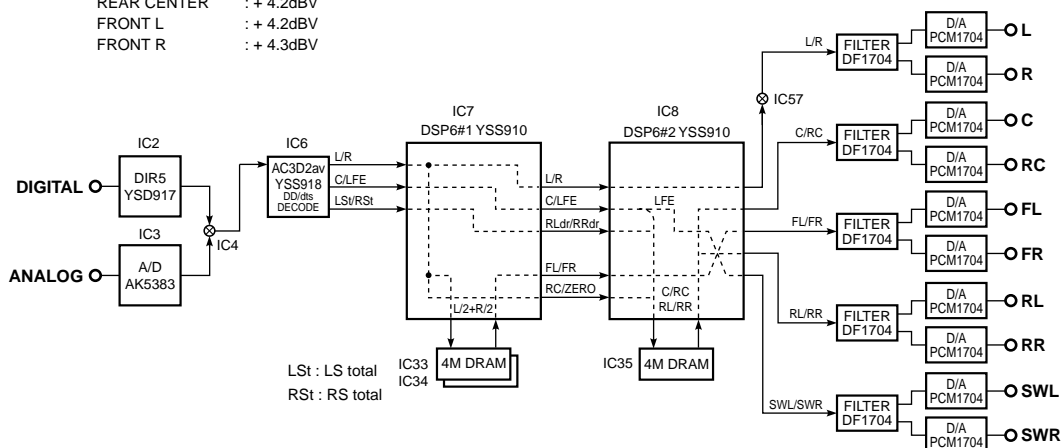

FULL BIT [Remote control code: 7A—92 (TUNER A/B/C/D/E)]

The head margin is unused and the digital data is output in full bit.

The same applies as "2ch/MULTI" 0dB" except that the digital data is output in full bit at D/A.

Reference	CD ANALOG IN	: -30dBV, Both ch		
	VOLUME	: MAX		
	PRE OUT			
	MAIN L (1kHz)	: -7.5dBV	REAR L (1kHz)	: -1.4dBV
	MAIN R (1kHz)	: -7.5dBV	REAR R (1kHz)	: -1.3dBV
	CENTER (1kHz)	: -7.2dBV	SW L (50Hz)	: +7.6dBV
	REAR CENTER (1kHz)	: -7.4dBV	SW R (50Hz)	: +7.5dBV
	FRONT L (1kHz)	: -7.5dBV	SW MONO (50Hz)	: +13.6dBV
	FRONT R (1kHz)	: -7.4dBV		

4. PRO LOGIC

The input data is automatically identified in the priority order of PCM > Analog. DTS is inhibited. There are three sub-menu items. Either Pro-logic (auto input balance turned off) or EFFECT OFF (analog through) is selected.

4. PRO LOGIC
YSS918

4. PRO LOGIC
YSS908

4. PRO LOGIC
EFFECT OFF

YSS918 [Remote control code: 7A—9C (SET DOWN)]

When the analog, PCM audio or DOLBY DIGITAL 2/0 mode is used, L, R, C, S signals are pro-logic decoded in YSS918 and output.

When the DOLBY DIGITAL mode other than 2/0 is used, the pro logic function does not work and they are muted.

(2-ch source) ... Muted in the case of multi-ch source

- AC3D2av outputs signals using PRO LOGIC decoding operation with the auto input balance off (with -3dB gain).
- DSP6#1 outputs the PRO LOGIC output signals to L/R (SD610), C(SD611, L only). Also, it passes the S signal through the external RAM and -3dB processing and outputs it to RLeF/RRef (SD613).
- DSP6#2 outputs the output signals of DSP6#1 to L/R (SD620), RL/RR (SD623). Also, it outputs the C signal to C (SD621, L only) through the external RAM.

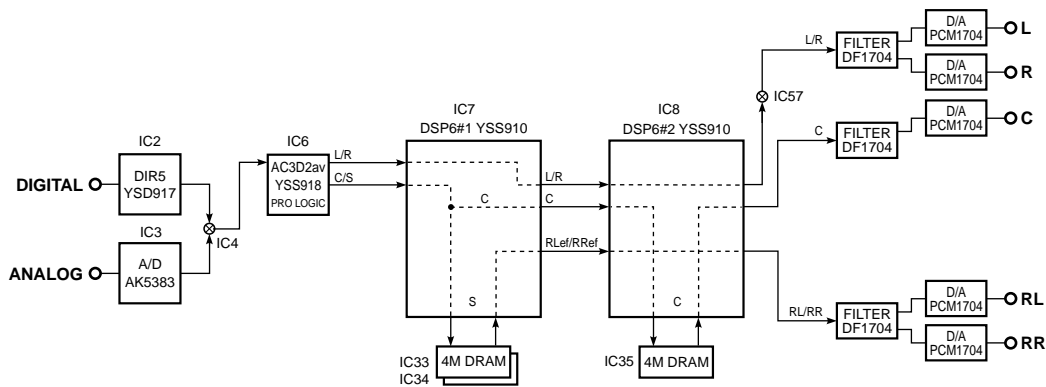

Reference	CD ANALOG IN	
	VOLUME	: -20dBV, Both ch
	PRE OUT	: MAX
	MAIN L (1kHz)	: -43.0dBV
	MAIN R (1kHz)	: -39.0dBV
	CENTER (1kHz)	: -0.2dBV
	REAR CENTER (1kHz)	: -47.5dBV
	FRONT L (1kHz)	: ∞ dBV
	FRONT R (1kHz)	: ∞ dBV
	REAR L (1kHz)	: ∞ dBV
	REAR R (1kHz)	: ∞ dBV
	SW L (50Hz)	: ∞ dBV
	SW R (50Hz)	: ∞ dBV
	SW MONO (50Hz)	: -44.8dBV

Reference	CD ANALOG IN	
	VOLUME	: -20dBV, L ch only
	PRE OUT	: MAX
	MAIN L (1kHz)	: -3.5dBV
	MAIN R (1kHz)	: ∞ dBV
	CENTER (1kHz)	: -42.4dBV
	REAR CENTER (1kHz)	: ∞ dBV
	FRONT L (1kHz)	: ∞ dBV
	FRONT R (1kHz)	: ∞ dBV
	REAR L (1kHz)	: -47.5dBV
	REAR R (1kHz)	: -47.5dBV
	SW L (50Hz)	: ∞ dBV
	SW R (50Hz)	: ∞ dBV
	SW MONO (50Hz)	: -44.8dBV

YSS908 [Remote control code: 7A—9D (SET UP)]

When the analog, PCM audio or DOLBY DIGITAL 2/0 mode is used, LS, RS, RC signals are pro-logic decoded in YSS908 and output.

When the DOLBY DIGITAL mode other than 2/0 is used, the pro logic function does not work and they are muted.

(2-ch source) ... Muted in the case of multi-ch source

- AC3D2av outputs 2-ch input signals from LSt/RSt (SDA21).
- AC3D2av outputs signals using DOLBY 3 Stereo decoding operation with the auto input balance off (with -3dB gain).
- DSP6#1 outputs LS/RS to RLdr/RRdr (SD612) and RC to RC (SD615, L only) respectively.
- DSP6#2 outputs the output signals of DSP6#1 to RL/RR (SD623) and RC (SD621, R only) through the external RAM.

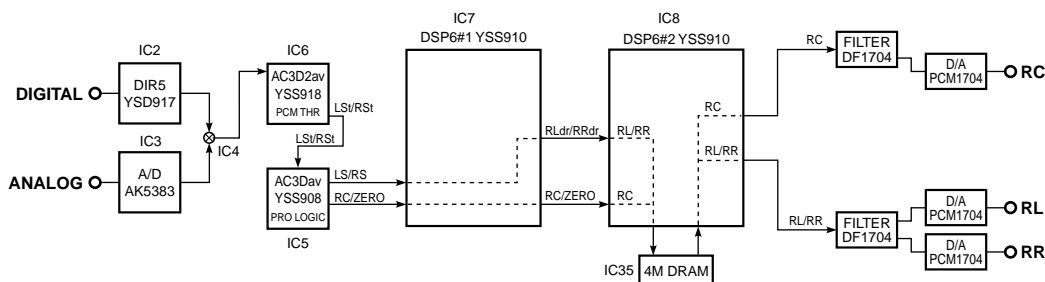

Reference	CD ANALOG IN VOLUME PRE OUT		CD ANALOG IN VOLUME PRE OUT	
	MAIN L (1kHz)	: -∞ dBV	MAIN L (1kHz)	: -∞ dBV
	MAIN R (1kHz)	: -∞ dBV	MAIN R (1kHz)	: -∞ dBV
	CENTER (1kHz/50Hz)	: -0.5dBV/ -2.0dBV	CENTER (1kHz)	: -∞ dBV
	REAR CENTER (1kHz)	: -∞ dBV	REAR CENTER (1kHz/50Hz)	: -42.6dBV/ -13.6dBV
	FRONT L (1kHz)	: -∞ dBV	FRONT L (1kHz)	: -∞ dBV
	FRONT R (1kHz)	: -∞ dBV	FRONT R (1kHz)	: -∞ dBV
	REAR L (1kHz/50Hz)	: -43.1dBV/ -12.2dBV	REAR L (1kHz/50Hz)	: -3.4dBV/ -5.3dBV
	REAR R (1kHz/50Hz)	: -38.7dBV/ -12.1dBV	REAR R (1kHz/50Hz)	: -∞ dBV/ -39.2dBV
	SW L (50Hz)	: -∞ dBV	SW L (50Hz)	: -∞ dBV
	SW R (50Hz)	: -∞ dBV	SW R (50Hz)	: -∞ dBV
	SW MONO (50Hz)	: -45.5dBV	SW MONO (50Hz)	: -45.5dBV

EFFECT OFF [Remote control code: 7A—9E (SET INC)]

- The input mode is fixed to Analog.
- The L/R signal is output through ANALOG MAIN BYPASS.

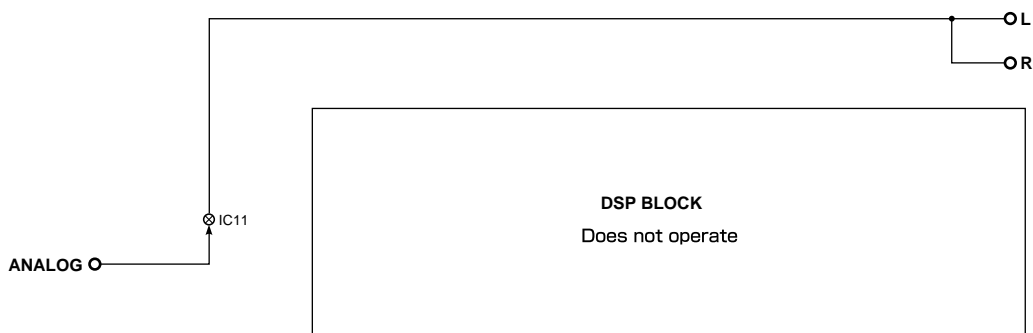

DSP-AX1/RX-V1

5. BYPASS

Only PCM and analog modes are used for input signals. The bypassing operation is used according to the menu setting. There are two sub-menu items (DECODER, DSP). This menu is useful when locating the faulty part by bypassing the decoder LSI and DSP6.



DECODER [Remote control code: 7A—9F (SET DEC)] (2-ch source) ... Muted in the case of multi-ch source

- AC3D2av, AC3Dav and DSP6#1 are muted.
- DIR5 or A/D output (SDAT) signals are input directly to DSP6#2 and output to L/R (SD620), C/R/C (SD621), RL/RR (SD623), FL/FR (SD622) and SWL/SWR (SD624).

Reference	CD ANALOG IN	: -20dBV, Both ch	
	VOLUME	: MAX	
	PRE OUT		
	MAIN L (1kHz)	: -7.5dBV	REAR L (1kHz) : -1.4dBV
	MAIN R (1kHz)	: -7.5dBV	REAR R (1kHz) : -1.3dBV
	CENTER (1kHz)	: -7.2dBV	SW L (1kHz/50Hz) : +7.7dBV/ +7.5dBV
	REAR CENTER (1kHz)	: -7.4dBV	SW R (1kHz/50Hz) : +7.7dBV/ +7.5dBV
	FRONT L (1kHz)	: -7.5dBV	SW MONO (1kHz/50Hz) : +13.8dBV/ +13.5dBV
	FRONT R (1kHz)	: -7.4dBV	

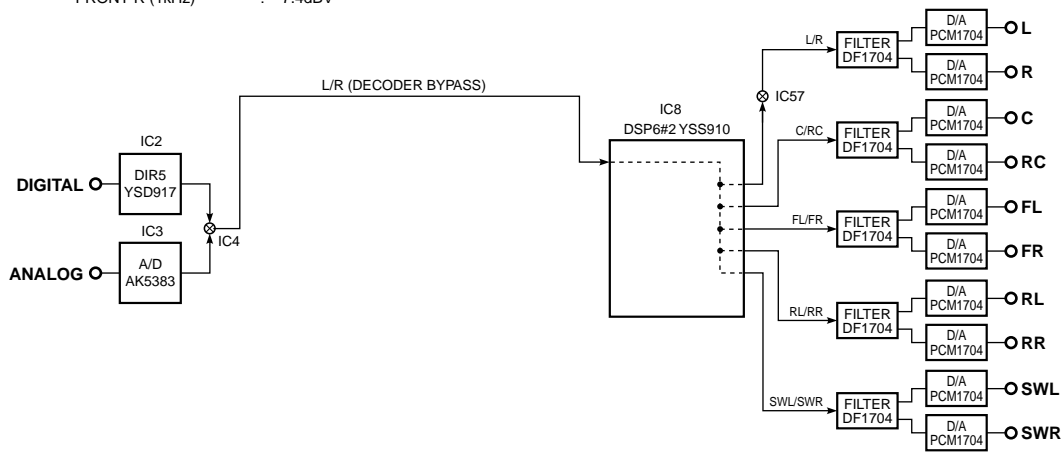

DSP [Remote control code: ----] (2-ch source) ... Muted in the case of multi-ch source

- AC3D2av, AC3Dav, DSP6#1 and DSP6#2 are muted.
- The DIR5 or A/D output (SDAT) signal is input directly to DAC and L/R is reproduced.

Reference	CD ANALOG IN	: -20dBV, Both ch	
	VOLUME	: MAX	
	PRE OUT		
	MAIN L (1kHz)	: -3.4dBV	REAR L (1kHz) : -∞ dBV
	MAIN R (1kHz)	: -3.4dBV	REAR R (1kHz) : -∞ dBV
	CENTER (1kHz)	: -∞ dBV	SW L (50Hz) : -∞ dBV
	REAR CENTER (1kHz)	: -∞ dBV	SW R (50Hz) : -∞ dBV
	FRONT L (1kHz)	: -∞ dBV	SW MONO (50Hz) : -∞ dBV
	FRONT R (1kHz)	: -∞ dBV	

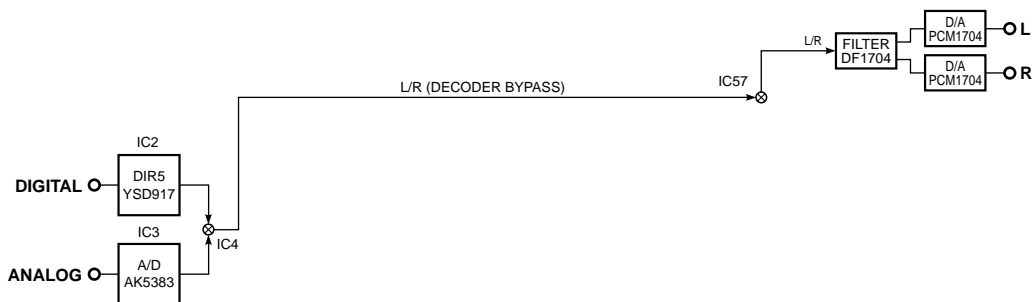

6. SPEAKERS SET

The input signal is automatically identified in the priority order of dts > DOLBY DIGITAL > PCM > Analog. There are seven sub-menu items.

The signals output from the DSP are the same as 1. DSP THROUGH: DSP 0dB.

[Remote Control Code: 7A—88 (PRG 1)]

```
6. SPEAKERS SET
MAIN:SMALL 0dB
```

[Remote Control Code: 7A—89 (PRG 2)]

```
6. SPEAKERS SET
MAIN:LARGE -10
```

[Remote Control Code: 7A—8A (PRG 3)]

```
6. SPEAKERS SET
CENTER:NONE
```

[Remote Control Code: 7A—8B (PRG 4)]

```
6. SPEAKERS SET
LFE/BASS:MAIN
```

[Remote Control Code: 7A—8C (PRG 5)]

```
6. SPEAKERS SET
FRONT MIX:5ch
```

[Remote Control Code: 7A—8D (PRG 6)]

```
6. SPEAKERS SET
CENTER:SMALL
```

[Remote Control Code: 7A—8E (PRG 7)]

```
6. SPEAKERS SET
REAR:SMALL
```

The analog switch settings for each sub-menu are as shown in the table below.

	Sub-menu	CENTER	REAR	MAIN SP	MAIN LVL	LFE/BASS	FRONT MIX
1	MAIN : SMALL 0dB	LARGE	LARGE	SMALL	0dB	SWFR	7ch
2	MAIN : LARGE -10	LARGE	LARGE	LARGE	-10dB	SWFR	7ch
3	CENTER : NONE	NONE	LARGE	LARGE	0dB	SWFR	7ch
4	LFE/BASS : MAIN	LARGE	LARGE	LARGE	0dB	MAIN	7ch
5	FRONT MIX : 5ch	LARGE	LARGE	LARGE	0dB	SWFR	5ch
6	CENTER : SMALL	SMALL	LARGE	LARGE	0dB	SWFR	7ch
7	REAR : SMALL	LARGE	SMALL	LARGE	0dB	SWFR	7ch

LARGE: Signals are output in all bandwidths.

SMALL: Only signals lower than 90Hz are mixed in the channel specified by LFE/BASS.

NONE: The center contents are distributed to the MAIN L/R channels after -3dB.

	Sub-menu	Application
1	MAIN : SMALL 0dB	Confirmation of high/low pass filter characteristic and gain when BASS REDIRECTION is used.
2	MAIN : LARGE -10	Confirmation of the effects of MAIN LEVEL function
3	CENTER : NONE	Confirmation of gain of CENTER MIX (Only CENTER contents are output from MAIN L/R.)
4	LFE/BASS : MAIN	Confirmation of gain of BASS MIX (Only LFE/BASS contents are output from MAIN L/R.)
5	FRONT MIX : 5ch	Confirmation of gain of FRONT MIX (Only FRONT contents are output from MAIN L/R.)
6	CENTER : SMALL	Confirmation of high/low pass filter characteristic and gain when BASS REDIRECTION is used.
7	REAR : SMALL	Confirmation of high/low pass filter characteristic and gain when BASS REDIRECTION is used.

7. DISPLAY CHK

This program is used to check lighting of the FL display which changes as shown below according to operation of the sub-menu.

The signals are processed in the same way as EFFECT OFF of No.4. (The L/R signal is output using ANALOG MAIN BYPASS setting.)

As for internal/external synchronization switching of super-imposing (image signals), forced external synchronization is selected by the microprocessor control.

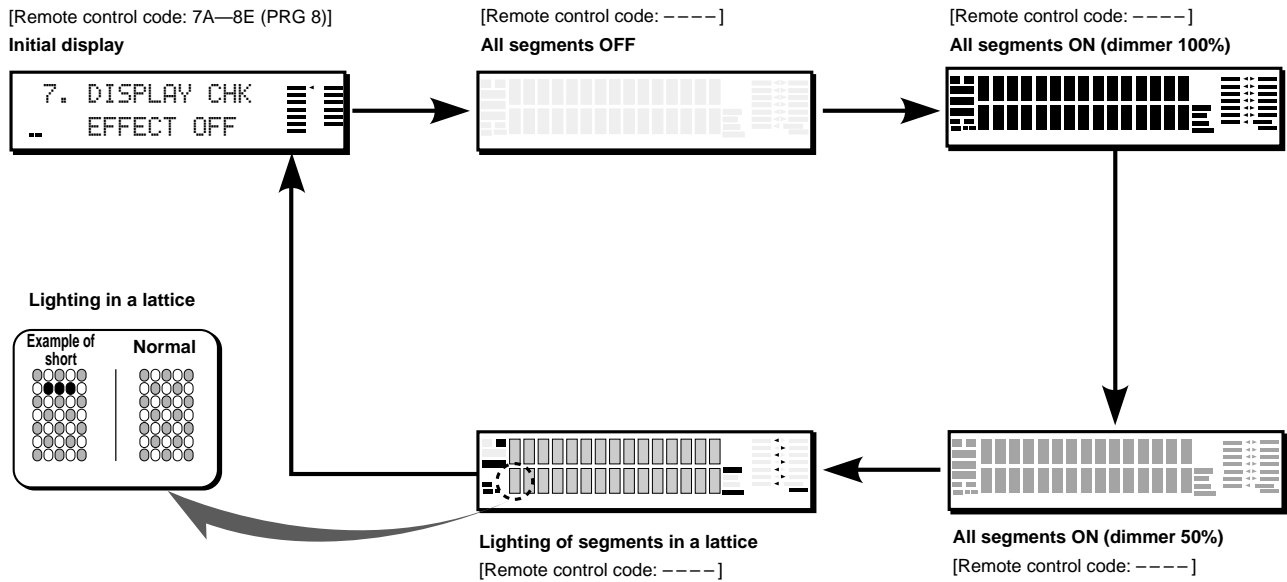

Segment conditions of the FL driver (IC901, IC902) and the FL tube are checked by turning ON and OFF all segments. Next, the operation of the FL driver is checked by using the dimmer control. Then a short between segments next to each other is checked by turning ON and OFF all segments alternately (in a lattice). (In the above example, the center segment in the second row from the top is shorted.)

8. MANUAL TEST

The test noise is output by the noise generator with a built-in DSP through the channels specified by the sub-menu. There are ten sub-menu items.

```
8. MANUAL TEST
  ALL
```

- ALL** [Remote control code: 7A—00 (TAPE PLAY)]
Noise is output through all channels.
- MAIN L** [Remote control code: 7A—01 (TAPE RW)]
Noise is output through the MAIN L channel.
- CENTER** [Remote control code: 7A—02 (TAPE FW)]
Noise is output through the CENTER channel.
- MAIN R** [Remote control code: 7A—03 (TAPE STOP)]
Noise is output through the MAIN R channel.
- REAR R** [Remote control code: 7A—04 (TAPE PAUSE)]
Noise is output through the REAR R channel.
- REAR C** [Remote control code: 7A—05 (TAPE MUTE)]
Noise is output through the REAR CENTER channel.
- REAR L** [Remote control code: 7A—06 (TAPE A/B)]
Noise is output through the REAR L channel.
- FRONT L** [Remote control code: 7A—07 (TAPE DIR A)]
Noise is output through the FRONT L channel.
- FRONT R** [Remote control code: 7A—08 (CD PLAY)]
Noise is output through the FRONT R channel.
- LFE** [Remote control code: 7A—09 (CD STOP)]
Noise is output through the LFE (sub-woofer) channel.

9. RS-232C

This menu is used to check transmission of the data and the flow port of the hardware. With the power turned off, short between pins No.2 (RxD) and No.3 (TxD) and between pins No.7 (RTS) and No.8 (CTS) of the RS-232C terminal. (Be sure to turn off the power when shorting pins.) Start DIAG and select the menu. There are two sub-menu items. The signals are processed in the same way as EFFECT OFF under item 4. PRO LOGIC. (The L/R signals are output using ANALOG MAIN BYPASS.)

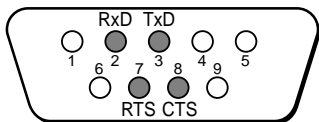

```
9. RS-232C
TxD/RxD DATA:XX
```

TxD/RxD DATA
This sub-menu is used to check transmission of the test data. "OK" appears when the data is transmitted properly and "NG" when it is not. In this mode, NULL command transmission is continued after the test command is transmitted.

```
9. RS-232C
HARD FLOW :XX
```

HARD FLOW
This sub-menu is used to check operation of the flow port of the hardware. "OK" appears when the check result is satisfactory and "NG" when it is not.

10. PRESET

This menu reserves and inhibits initialization of the back-up RAM (parameter, set menu contents, etc. for the sound field program). The input signals are automatically identified in the priority order of AC-3 > PCM > Analog. The signals are processed in the same way as EFFECT OFF of No.4.

10. PRESET INHIBIT

INHIBIT (Initialization inhibited)

RAM initialization is not executed. Select INHIBIT to protect the values set by the user.

10. PRESET RESERVED

RESERVED

Initialization of the back-up RAM is reserved and it is executed when the power is turned ON after canceling DIAG. RESERVED should be selected when shipping out of the factory or resetting RAM.

CAUTION : Before setting to the PRESET RESERVED, write down the existing preset memory content of the Tuner in a table as shown below. (This is because setting to the PRESET RESERVED will cause the user memory content to be erased.) (RX-V1 only)

Preset group	P1	P2	P3	P4	P5	P6	P7	P8
A								
B								
C								
D								
E								

● PRESET STATIONS

STATION		FM FACTORY PRESET DATA (MHz)			STATION		AM FACTORY PRESET DATA (kHz)	
PAGE	NO.	U, C, R, T	R, T, L, A	J	PAGE	NO.	U, C, R, T	R, T, L, A, J
A/C/E	1	87.5	87.5	76.0	B/D	1	630	630
	2	90.1	90.1	83.0		2	1080	1080
	3	95.1	95.1	84.0		3	1440	1440
	4	98.1	98.1	86.0		4	530	531
	5	107.9	108.0	90.0		5	1710	1611
	6	88.1	88.1	78.0		6	900	900
	7	106.1	106.1	88.0		7	1350	1350
	8	107.9	108.0	82.1		8	1400	1404

12. IF STATUS

Using this menu, the status data is displayed in the hexadecimal notation one after another. During signal processing, the status before execution of this menu is maintained. If the input mode is analog fixed in the menu before execution, it is necessary to change it to the digital mode according to the following procedure.

- 1) Select either DIAG menu No.2 or No.3 and enter a digital signal.
- 2) Menu No.12 can be selected by pressing the INPUT MODE key of the main unit. (The input mode will be fixed to the digital mode.)

There are ten sub-menu items. The following status information is displayed in the hexadecimal notation according to the sub-menu operation.

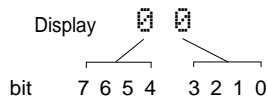
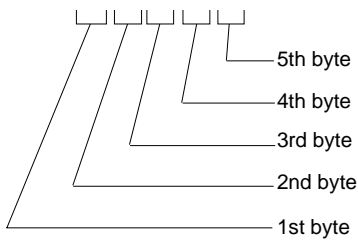
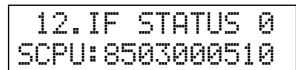

Display	bit			
	3	2	1	0
0	0	0	0	0
1	0	0	0	1
2	0	0	1	0
3	0	0	1	1
4	0	1	0	0
5	0	1	0	1
6	0	1	1	0
7	0	1	1	1
8	1	0	0	0
9	1	0	0	1
A	1	0	1	0
B	1	0	1	1
C	1	1	0	0
D	1	1	0	1
E	1	1	1	0
F	1	1	1	1

Example: "E 1" reads as follows.

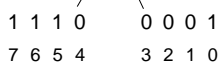

IF STATUS 0: Indicates the information communicated between sub-micro-processors.

1st byte

Indicates the communication time lag between the main microprocessor and the sub-microprocessor, malfunction (in display, etc.) caused by a communication error or some other reason, the input mode selected by the sub-microprocessor to deter the flickering effect and the head phone state.

bit 7	HEAD PHONE IN
bit 6	0
bit 5	EXT.DECODER IN
bit 4	0
bit 3	From 0000b, PHONO/TUNER/CD/MD/TAPE/DVD/
bit 2	LD/D-TV/CBL-SAT/VCR1/VCR2/VCR3/
bit 1	V-AUX/NONE/there after ERROR
bit 0	

2nd byte

Indicates the Fs information of the reproduction signals.

0x00 : analog
 0x01 : 32kHz 0x02 : 44.1kHz 0x03 : 48kHz 0x04 : 64kHz 0x05 : 88kHz
 0x06 : 96kHz 0x07 : Unknown
 Other : Error

3rd byte

Indicates the audio code mode information of the reproduction signals.

0x00 : 1+1 0x01 : 1/0 0x02 : 2/0 0x03 : 3/0 0x04 : 2/1
 0x05 : 3/1 0x06 : 2/2 0x07 : 3/2 0x08 : dts7.1
 Other : Error

4th byte

Indicates the format information of the reproduction signals.

0x00 : analog (Unlock) 0x01 : Wrong digital (*1)
 0x02 : Digital Data 0x03 : IEC1937 Data 0x04 : PCM Audio
 0x05 : Dolby Digital 0x06 : D.D.Karaoke 0x07 : D.D.EX
 0x08 : RED dts 0x09 : ORANGE dts 0x0A : dts ES
 Other : Error

(*1): Digital reproduction cannot be used due to a commercial bit or 4ch audio reason. So analog reproduction is used.

5th byte

Indicates the information on the signal processing status.

bit7	MUTE requested
bit6	dts flashing
bit5	6.1/ES sound field being processed
bit4	RF-DEM mute pin
bit3	MAIN commands all requested
bit2	THROUGH & BYPASS (*2)
bit1	6.1/ES AUTO
bit0	dts analog muted

(*2): In the case of digital signals other than 32kHz, 44.1kHz and 48kHz, through processing is used for reproducible signals.

IF STATUS 1: Version information of sub-microprocessor (Asky code)

```
12. IF STATUS 1
VER. : 41323541
```

IF STATUS 2: Checksum of sub-microprocessor (Asky code)

```
12. IF STATUS 2
SUM : 46423732
```

IF STATUS 3~7: IEC60958 channel status information of input signals

```
12. IF STATUS 3
CHS1: 0299000299
```

```
12. IF STATUS 7
CHS5: 00000000
```

IF STATUS 8~11: Bit stream information included in the DOLBY DIGITAL signal (indicated one by one from the 1st byte)

```
12. IF STATUS 8
BSI1: 0000000000
```

```
12. IF STATUS11
BSI4: 000000FF00
```

IF STATUS 12: Bit stream information included in the dts signal

```
12. IF STATUS12
BSID: FFFFFFFF
```

IF STATUS 13: Device status information of DIR5 (IC2)

```
12. IF STATUS13
DIR5: 1A418000
```

IF STATUS 14: Device status information of YSS918 (IC6)

```
12. IF STATUS14
Y918: 01014180
```

IF STATUS 15: Device status information of YSS908 (IC5)

```
12. IF STATUS15
Y908: 00010100
```

IF STATUS 16: Device status information of DSP6 (IC7, IC8)

```
12. IF STATUS16
DSP6: 00000000
```

IF STATUS 17: External RAM check status information of DSP6#1 (IC7)

```
12. IF STATUS17
RAM1: 4E6F4572
```

IF STATUS 18: External RAM check status information of DSP6#2 (IC8)

```
12. IF STATUS18
RAM2: 4E6F4572
```

13. DSP RAM CHECK

This menu is used to self-diagnose whether or not the external RAM (IC33, 34, 35) and DSP (IC7, 8) are connected properly, utilizing the CPU -Ext. RAM interface function included in DSP6. During signal processing, the status before execution of this menu is maintained.

```
13.DSP RAM CHECK
#1:NoEr #2:NoEr
```

#1, #2

Checks the address bus and the data bus of DSP#1 (IC7 of DSP circuit board) and DSP#2 (IC8 of DSP circuit board), and indicates the connection condition. "NoEr" appears when no error is detected.

When an error is detected in the data bus;
 1619 (example): Indicates that there is an incorrect value between bits 16 and 19. If there are two or more incorrect values, priority is placed on the LSB side.

When an error is detected in the address bus;
 Ad01 (example): Indicates that the address bit 1 has an error.
 Ad17 (example): Indicates that the address bus bit 17 has an error. (With this product, however, it is possible that A8 and /OE are short-circuited.)

- Note that a bus error may be indicated also when there is an error with the terminal other than above buses.
- Detection for the bus check is executed immediately after resetting.
 An error which has occurred after starting DIAG cannot be detected.

14. SUM/VER /PORT

There are four sub-menu items. Indicates the checksum, version, port of the main microprocessor (IC27 of the function circuit board) as well as the checksum and version of the sub-microprocessor (IC1 of the DSP circuit board). The signals are processed in the same way as EFFECT OFF under item 4. PRO LOGIC. (The L/R signals are output using ANALOG MAIN BYPASS.)

CAUTION : When replacing the microprocessor, be sure to check the microprocessor compatibility before replacement. The microprocessor may not be suitable for replacement depending on its communication format. Use of a microprocessor whose communication format is not compatible with the existing one will cause some communication error between microprocessors.

```
14.SUM/VER/PORT
M:51F5 / S:A3BB
```

Checksum of main/sub microprocessor

Checksum: The checksum is obtained by adding 4M bits per 1 octo of the entire program code and expressing the result as a 4-figure hexadecimal data. (0xf is added for the area where no code has been entered and for the area other than ROM code.)

Checksum of sub-microprocessor
 (4 figures of alphabets and numbers)

Checksum of main microprocessor
 (4 figures of alphabets and numbers)

```
14.SUM/VER/PORT
M:G38DB/ S:E42D
```

**Software version/compatible version/RS-232C version of main microprocessor
Software version and compatible version of sub-microprocessor**

The alphabet of the compatible version represents the communication format compatibility between the main and sub microprocessors. If the alphabet representing the communication format compatibility agrees, the microprocessors are interchangeable. If the alphabet is different, the replacement microprocessor will fail to function properly.

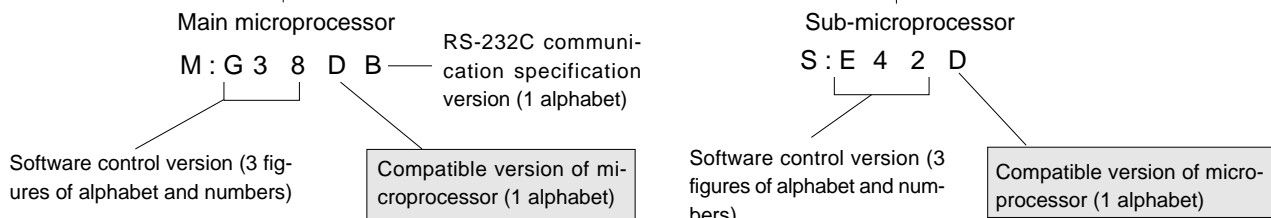

```
14.SUM/VER/PORT
PORT: 00000000
```

Port to check functions of the main microprocessor

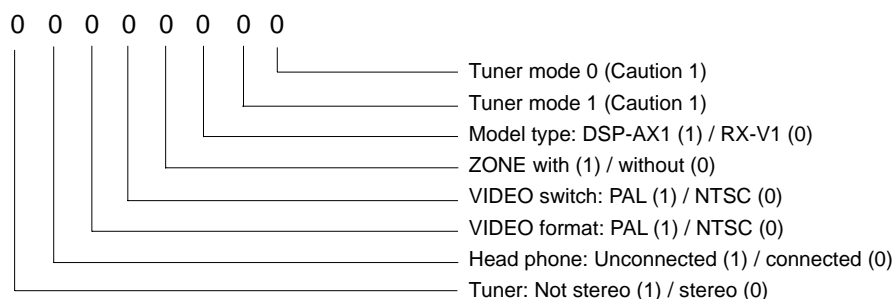

(Caution 1)

Tuner mode 0	Tuner mode 1	Tuner frequency
0	0	AM : 531-1611kHz/9kHz FM : 76.0-90.0MHz/100kHz
0	1	AM : 531-1611kHz/9kHz FM : 87.5-108.0MHz/50kHz
1	0	AM : 530-1710kHz/10kHz FM : 87.5-107.9MHz/200kHz
1	1	DSP-AX1

Port to check functions of the REC OUT

```
14.SUM/VER/PORT
REC-OUT: 0000
```

bit 3 2 1 0
0 0 0 0

REC OUT	bit			
	3	2	1	0
PHONO	0	1	1	1
CD	0	1	1	0
TUNER	0	1	0	0
TAPE	0	1	0	1
MD	0	0	0	1
DVD	0	0	0	0
SOURCE	0	0	1	0
LD	0	0	1	1
D-TV	1	0	1	1
CBL/SAT	1	0	1	0
VCR1	1	0	0	0
VCR2	1	0	0	1
VCR3	1	1	0	1
V-AUX	1	1	0	0

AMP ADJUSTMENTS

● IDLING CURRENT ADJUSTMENT

Before this adjustment, wait for 10 minutes with no signal applied after the power is turned ON.

Item	Test Point	Adjustment point	Rating (DC)
MAIN L	CB503	VR504	4.0mV to 12.0mV
MAIN R	CB504	VR505	
CENTER	CB505	VR506	
REAR L	CB506	VR501	2.0mV to 6.0mV
REAR R	CB507	VR502	
REAR CENTER	CB508	VR503	
FRONT L	CB509	VR507	4.0mV to 12.0mV
FRONT R	CB510	VR508	

● Test Point

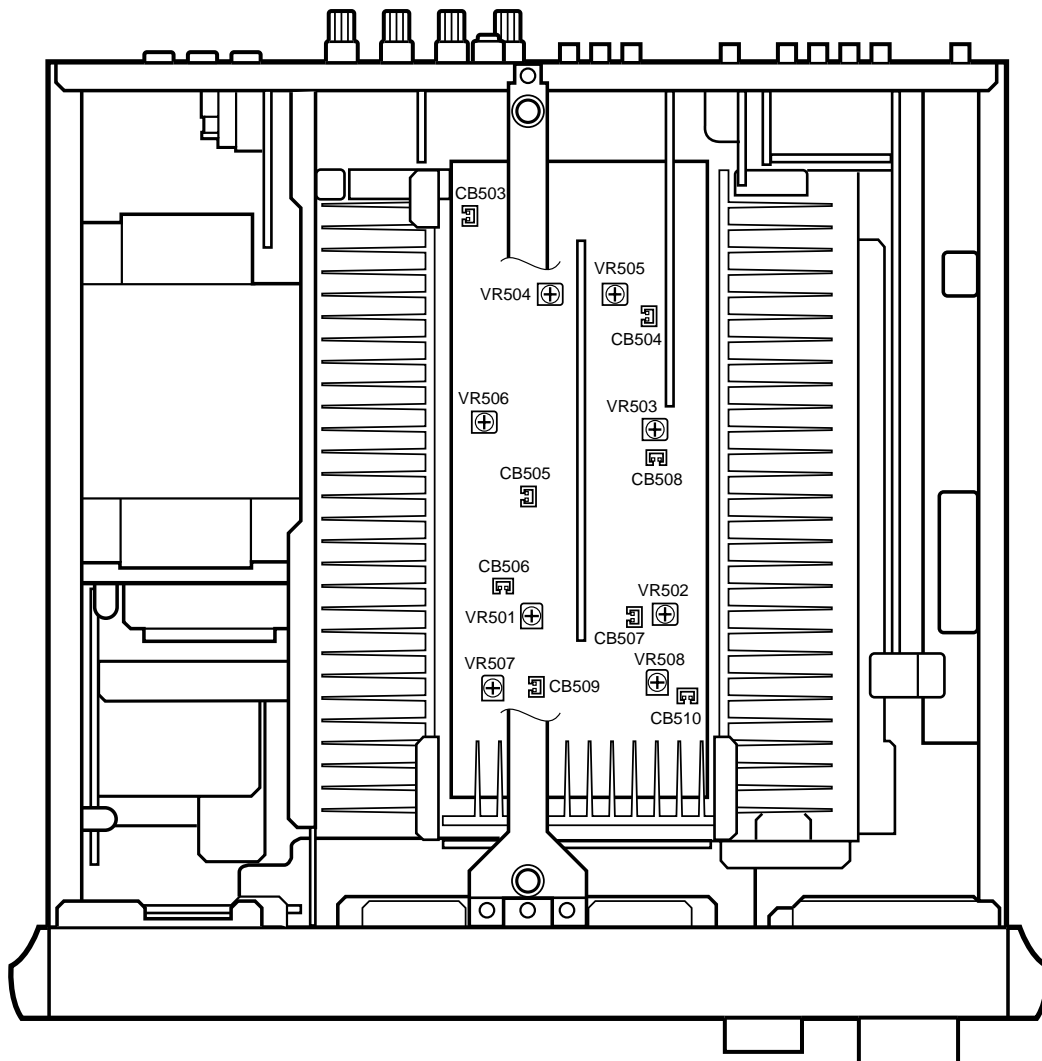

■ TUNER ADJUSTMENTS (RX-V1 only)

● Measuring Instruments

- FM signal generator (FM SG)
- Stereo signal generator (SSG)
- AM signal generator (AM SG)
- Distortion meter (DIST. M)
- AC voltmeter (ACVM)
- DC voltmeter (DCVM)
- Oscilloscope
- Low pass filter (YLF-15, $f_c=15\text{kHz}$)
- Oscillator

● Dummy antenna

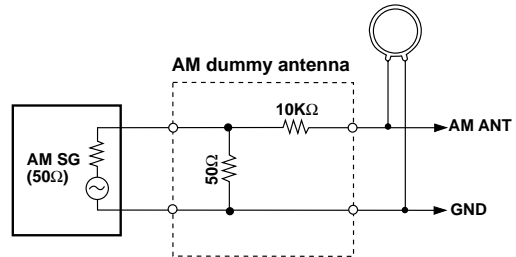
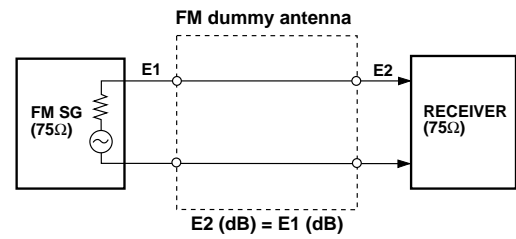
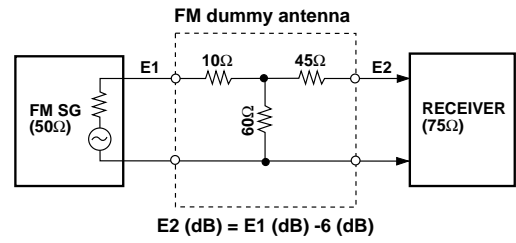

● Test point

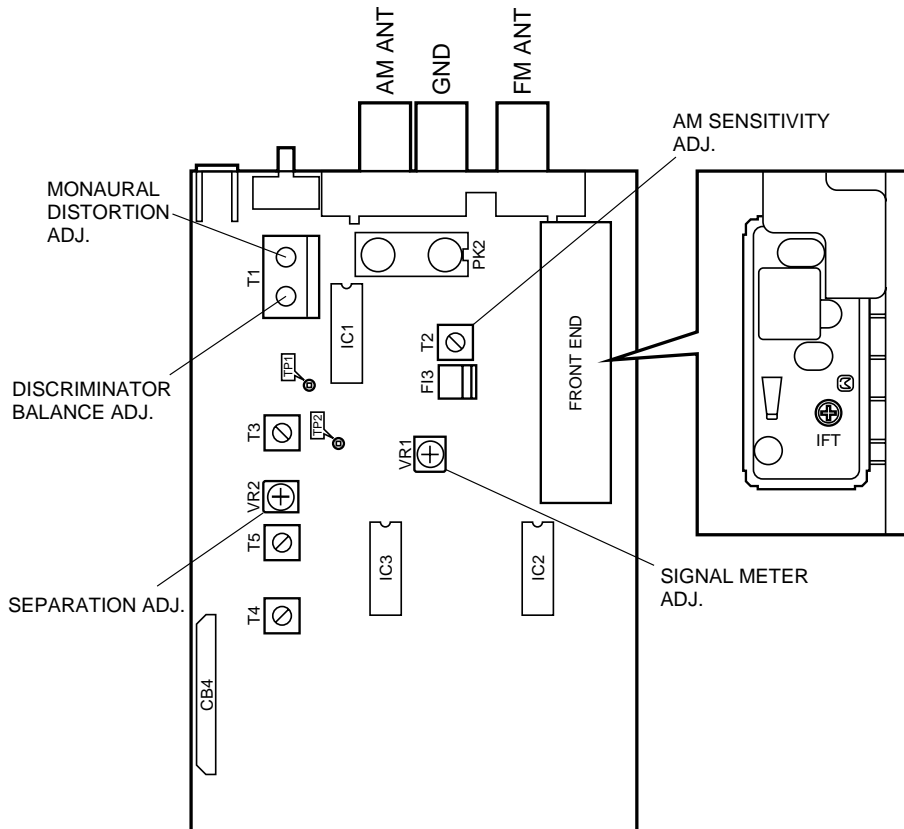

FM Adjustment

● **Before Adjustment**

- 1) For dB, $1\mu V=0dB\mu$
Example : $60dB\mu=1mV$
- 2) 100% modulation means that the frequency deviation is $\pm 75kHz$.

- 3) Install the Matching Transformer and connect FM SG.
- 4) Set each switch to the following position unless otherwise specified.

INPUT SELECTOR TUNER
 TUNING MODE AUTO

● **Connection diagram (Measuring instruments)**

1) **Discriminator balance adjustment**

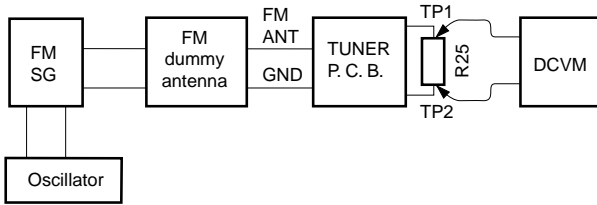

3) **Stereo distortion adjustment/separation adjustment**

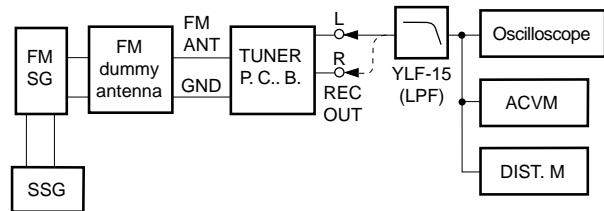

2) **Monaural distortion adjustment**

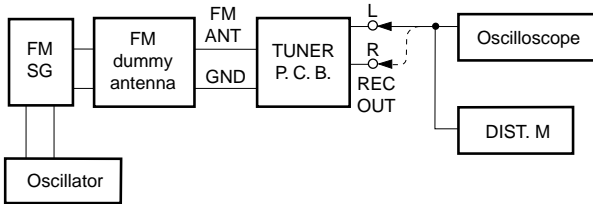

4) **Sensitivity Verification**

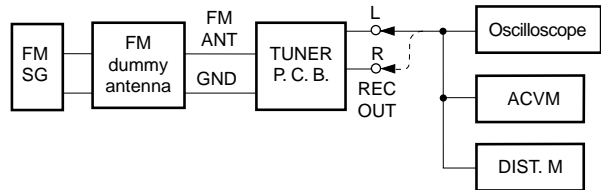

See page 34 for TP locations & adjustment points.

Step	Adjustment item	Signal (ANT IN)	Reception frequency	Adjustment point	Test point	Rating
1	Rough adjustment of discriminator balance	FM ANT (75Ω) 98.1MHz \pm 5kHz 70dBμ MONO 100Hz 100% modulation	98.1MHz * (A-4)	T1 (IC side core)	Both ends of R25 (Between TP1 and TP2)	DC 0V \pm 100mV
2	Rough adjustment of monaural distortion	Same as Step 1.	98.1MHz * (A-4)	T1 (Antenna side core)	REC OUT L, R	Minimize the distortion.
3	Fine adjustment of discriminator balance	Same as Step 1.	98.1MHz * (A-4)	T1 (IC side core)	Both ends of R25 (Between TP1 and TP2)	DC 0V \pm 50mV
4	Fine adjustment of monaural distortion	Same as Step 1.	98.1MHz * (A-4)	T1 (Antenna side core)	REC OUT L, R	Minimize the distortion (to 0.25% or less).
5	Verification of discriminator balance	Same as Step 1.	98.1MHz * (A-4)	T1 (IC side core)	Both ends of R25 (Between TP1 and TP2)	DC 0V \pm 50mV

* : Execution of PRESET (Refer to page 27.) will facilitate setting reception frequency for adjustment.

Step	Adjustment item	Signal (ANT IN)	Reception frequency	Adjusted point	Test point	Rating
6	Adjustment of front end IFT	FM ANT (75Ω) 98.1MHz ± 5kHz 30dBμ MONO 1kHz, 100% modulation	98.1MHz * (A-4)	Front end IFT	Pin 16 of IC1	Adjust so that the DC voltage is maximum. CAUTION : Over-adjustment of the IFT core will reduce the sensitivity. Maximum ±90°
7	Verification of monaural distortion	FM ANT (75Ω) 98.1MHz 70dBμ MONO 1kHz, 100% modulation	98.1MHz * (A-4)		REC OUT L, R	0.4% or less
8	Verification of stereo distortion	FM ANT (75Ω) 98.1MHz 70dBμ Stereo L or R 1kHz, 100% modulation	98.1MHz * (A-4) * Tuning mode should be AUTO.		REC OUT L, R	1% or less •STEREO indicator should light.
9	Verification of sensitivity	FM ANT (75Ω) 88.1MHz 98.1MHz 106.1MHz MONO 1kHz 100% modulation	88.1MHz * (A-6) 98.1MHz * (A-4) 106.1MHz * (A-7)		ANT (75Ω)	1) Set the tuning mode to MAN'L MONO. (Muting OFF) 2) S/N should be 30dB at each frequency of 88.1MHz, 98.1MHz, and 106.1MHz. 3) Check to ensure that the voltage at the ANT terminal is 5dBμ or less. (A only : 7dBμ or less)
10	Adjustment of Separation	FM ANT (75Ω) 98.1MHz 70dBμ Stereo L or R 1kHz, 100% modulation	98.1MHz * (A-4)	VR2	REC OUT L, R	With SSG output at L or R, the signal leakage level at the other channel should be minimized. 35dB or more
11	Adjustment of Signal meter	FM ANT (75Ω) 98.1MHz 45dBμ MONO 1kHz 30% modulation	98.1MHz * (A-4)	VR1		Adjust so that all segments light.
		-10dBμ or less				Check to ensure that signal meters turn OFF.
12	Verification of auto tuning	FM ANT (75Ω) 98.1MHz 26dBμ Stereo L or R 1kHz, 30% modulation	98.1MHz			•Automatic reception should be available when the tuning key is moved UP and DOWN. •The stereo indicator should light. •Audio muting should be applied during tuning.

* : Execution of PRESET (Refer to page 27.) will facilitate setting reception frequency for adjustment.

AM Adjustment (This should be done after FM adjustment.)

● **Connection Diagram (Measuring instruments)**

1) Adjustment of sensitivity

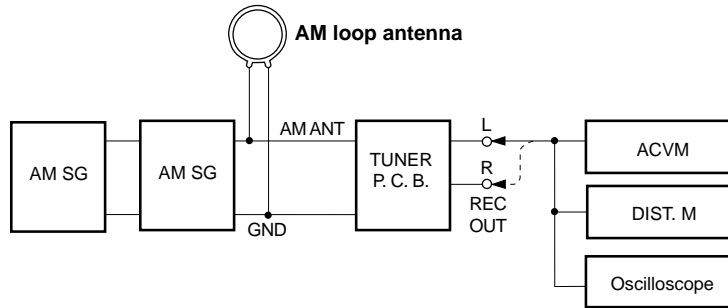

See page 34 for TP locations & adjustment points.

Step	Adjustment item	Signal (ANT IN)	Reception frequency	Adjustment point	Test point	Rating
1	Adjustment of sensitivity (1440Hz)	AM ANT 1440kHz 50dB μ 1kHz 30% modulation	1440kHz * (B-3)	T2	REC OUT	Audio output should be maximized.
2	Verification of sensitivity (630kHz)	AM ANT 630kHz 50dB μ 1kHz 30% modulation	630kHz * (B-1)	T2	REC OUT	Audio output should be maximized. Repeat the Step 1 and 2.
3	Verification of sensitivity	AM ANT 630kHz 1080kHz 1440kHz 30% modulation	630kHz * (B-1) 1080kHz * (B-2) 1440kHz * (B-3)		AM ANT	Distortion should be 10% or less at each frequency. Check to ensure that the voltage at the ANT terminal is 54dB μ or less.
4	Verification of auto tuning	AM ANT 60dB μ				Auto reception should be available when the tuning key is moved UP and DOWN.

* : Execution of PRESET (Refer to page 27.) will facilitate setting reception frequency for adjustment.

● ANODE CONNECTION

	1GA~15GA	16GA		16B~156B	166B
P1A	1-1	SLEEP	P1B	1-1	dtc
P2A	2-1	ZONE 2	P2B	2-1	VIRTUAL
P3A	3-1	▷ (PHONO)	P3B	3-1	DIGITAL
P4A	4-1	▷ (CD)	P4B	4-1	PRO LOGIC
P5A	5-1	▷ (TUNER)	P5B	5-1	DSP
P6A	1-2	▷ (TAPE)	P6B	1-2	EX/ES
P7A	2-2	▷ (MD)	P7B	2-2	PCM
P8A	3-2	▷ (DVD)	P8B	3-2	-
P9A	4-2	▷ (LD)	P9B	4-2	SPEAKERS
P10A	5-2	▷ (D-TV)	P10B	5-2	A
P11A	1-3	▷ (CBL/SAT)	P11B	1-3	B
P12A	2-3	▷ (VCR1)	P12B	2-3	HEADPHONE
P13A	3-3	▷ (VCR2)	P13B	3-3	DI
P14A	4-3	▷ (VCR3)	P14B	4-3	-
P15A	5-3	▷ (V-AUX)	P15B	5-3	-
P16A	1-4	S1	P16B	1-4	-
P17A	2-4	STEREO	P17B	2-4	-
P18A	3-4	AUTO TUNING	P18B	3-4	-
P19A	4-4	MEMORY	P19B	4-4	-
P20A	5-4	-	P20B	5-4	-
P21A	1-5	-	P21B	1-5	-
P22A	2-5	-	P22B	2-5	-
P23A	3-5	-	P23B	3-5	-
P24A	4-5	-	P24B	4-5	-
P25A	5-5	-	P25B	5-5	-
P26A	1-6	-	P26B	1-6	-
P27A	2-6	-	P27B	2-6	-
P28A	3-6	-	P28B	3-6	-
P29A	4-6	-	P29B	4-6	-
P30A	5-6	-	P30B	5-6	-
P31A	1-7	-	P31B	1-7	-
P32A	2-7	-	P32B	2-7	-
P33A	3-7	-	P33B	3-7	-
P34A	4-7	-	P34B	4-7	-
P35A	5-7	-	P35B	5-7	-

IC DATA

IC27 : M30624FGFP (P.C.B. FUNCTION)
16 bit μ-COM (Main CPU)

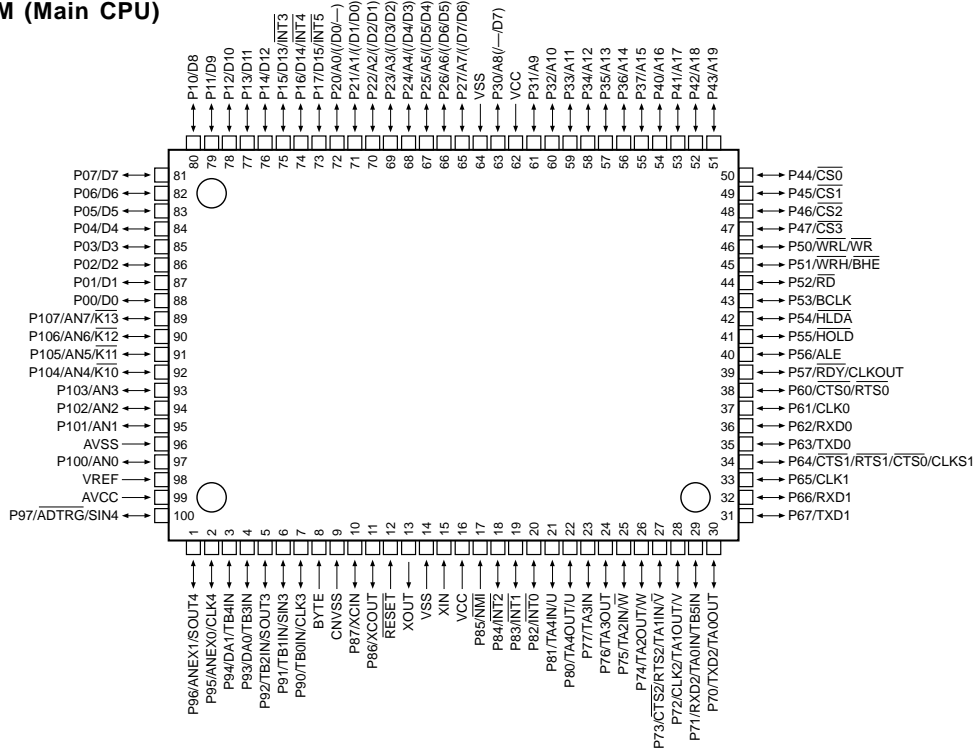

No.	PORT	Name	I/O	Function	Power On	Power Off	Backup
1	SOUT4	DTC	O	SDT for CS3310	SO	OL	OL
2	CLK4	CKC	SCK	SCK for CS3310	SCK	OL	OL
3	DA1	FAN	DA	Fan Control	I	I	OL
4	P93	/SBR	O	Reset for Sub CPU	O	O	OL
5	SOUT3	MTS	SO	CPU I/F Main to Sub	OL	OL	OL
6	SIN3	STM	SI	CPU I/F Sub to Main	I	I	OL
7	CLK3	MCBC	SCK	Bit Clock	OL	OL	OL
8	BYTE	BYTE	VSS	Single Chip Mode : VSS	VSS	VSS	VSS
9	CNVSS	CNVSS	VSS/VCC	Single Chip Mode : VSS, Flush Write : VCC	VSS	VSS	VSS
10	P87	TRQ	I	CPU I/F Transfer Request	I	I	OL
11	P86	MCWC	I	CPU I/F Word Clock	I	I	OL
12	RESET	/RES	I	Reset	---	---	---
13	XOUT	XOUT	OPEN	Oscillator out	---	---	---
14	VSS	VSS	VSS	Ground	---	---	---
15	XIN	XIN	12MHz	Oscillator in	---	---	---
16	VCC	VCC	VCC	+ 5V	---	---	---
17	NMI	NMI	VCC	Not used (pull-up VCC)	I	I	I
18	INT2	PSW	INT	Power Switch (High Edge : Interrupt)	I	I	OL
19	INT1	PDT	INT	Power Detect (Low Edge : Interrupt)	I	I	I
20	INT0	REM2	INT	ZONE 2 Remote in (Low Edge : Interrupt)	I	I	OL
21	P81	SCKA	SCK	SCK for Audio	O	OL	OL
22	P80	SDTA	SO	SDT for Audio	O	OL	OL
23	P77	CET	O	CE Toshiba for Audio	O	OL	OL
24	P76	CEL	O	CE Sanyo for Audio	O	OL	OL
25	P75	SPE	O	Speaker Relay Effect	O	OL	OL
26	P74	SPB	O	Speaker Relay B	O	OL	OL
27	P73	SPA	O	Speaker Relay A	O	OL	OL
28	CLK2	SCKN	SCK	SCK for Non Audio	SCK	OL	OL
29	TB5IN	VSY	TBIN5	Video Vertical Sync (Connection pin 24)	I	I	OL

DSP-AX1/RX-V1

DSP-AX1/RX-V1

**IC27 : M30624FGFP (P.C.B. FUNCTION)
16 bit μ -COM (Main CPU)**

No.	PORT	Name	I/O	Function	Power On	Power Off	Backup
30	TXD2	SDTN	O	SDT for Non Audio	SO	OL	OL
31	TXD1	TXDF	FLASH	Serial Write Data Transmission for Flash ROM	OL	OL	OL
32	RXD1	RXDF	FLASH	Serial Data Reception for Flash ROM	OL	OL	OL
33	CLK1	CLKF	FLASH	SCK for Flash ROM	OL	OL	OL
34	P64	BUSY	O/FLASH	232C RTS out/Flash BUSY out	O	OL	OL
35	TXD0	TXDR	ASO	232C Transmission Data	O	O	OL
36	RXD0	RXDR	ASI	232C Reception Data	I	I	OL
37	P61	CEM0	O	CE for FL1	O	OL	OL
38	CTS0	CTS	I	232C CTS input	I	I	OL
39	P57	CEM1	O	CE for FL2	O	OL	OL
40	P56	/FLR	O	FL IC Reset	O	OL	OL
41	HOLD	/HOLD	GND	For Flash Write	I	I	I
42	P54	CES	O	CE for On Screen	I	I	OL
43	P53	E/I	O	Video Internal/External	O	OL	OL
44	P52		OPEN	Not used	OL	OL	OL
45	P51	/ST	I	Tuner Stereo	I	I	OL
46	P50		I	For Flash Write	I	I	I
47	P47	SDTP	SO	SDT for Tuner PLL	O	OL	OL
48	P46	RDTP	SI	RDT for Tuner PLL	I	I	OL
49	P45	SCKP	SCK	SCK for Tuner PLL	O	OL	OL
50	P44	CEP	O	CE for Tuner PLL	O	OL	OL
51	P43	/TMT	O	Tuner Mute	O	OL	OL
52	P42	CEC	O	CE for CS3310	O	OL	OL
53	P41	ISB	I	Input Selector B	I	I	OL
54	P40	ISA	I	Input Selector A	I	I	OL
55	P37		OPEN	Not used	OL	OL	OL
56	P36	P/N	I	PAL/NTSC SW (0 : NTSC, 1 : PAL)	I	I	OL
57	P35	CMP1	O	Component 1	O	OL	OL
58	P34	CMP0	O	Component 0	O	OL	OL
59	P33	ZONE2	I(PU)	ZONE2 function (0 : present, 1 : absent)	I(PU)	I(PU)	OL
60	P32	TYPE	I(PU)	Model detect (0 : RX-V1, 1 : DSP-AX1)	I(PU)	I(PU)	OL
61	P31	TUN1	I(PU)	Tuner Mode 1 (Note 1)	I(PU)	I(PU)	OL
62	VCC	VCC	VCC	+ 5V	---	---	---
63	P30	TUN0	I(PU)	Tuner Mode 0 (Note 1)	I(PU)	I(PU)	OL
64	VSS	VSS	VSS	Ground	---	---	---
65	P27		OPEN	Not used	OL	OL	OL
66	P26	/MLV	O	Main Level Select (0/-10dB)	O	OL	OL
67	P25	/Z2MT	O	ZONE2 Mute	O	OL	OL
68	P24	/HPMT	O	Head Phone Mute	O	OL	OL
69	P23	/FMFTF	O	Full Mute (FL/FR)	O	OL	OL
70	P22	/FMFTS	O	Full Mute (SWL/SWR/SW MONO)	O	OL	OL
71	P21	/FMFTC	O	Full Mute (CENTER)	O	OL	OL
72	P20	/FMFTM	O	Full Mute (MAINL/R, RL/RC/RR)	O	OL	OL
73	INT5	RXDR	INT	232C Reception Data (Connection pin 29)	I	I	OL
74	INT4	VSY	INT	Video Vertical Sync ((Low Edge : Interrupt)	I	I	OL
75	INT3	REM	INT	Remote in (Low Edge : Interrupt)	I	I	OL
76	P14	CEB	O	CE for BU2092	O	OL	OL
77	P13	RSEL3	I	REC OUT Selector 3	I	I	OL
78	P12	RSEL2	I	REC OUT Selector 2	I	I	OL
79	P11	RSEL1	I	REC OUT Selector 1	I	I	OL
80	P10	RSEL0	I	REC OUT Selector 0	I	I	OL
81	P07	/HPI	I	Head Phone Detect	I	I	OL
82	P06	VCPN	O	NTSC/PAL Format (0 : NTSC, 1 : PAL)	I	I	OL
83	P05	/CSM	O	Reset for CS3310	O	OL	OL
84	P04		O	Not used	OL	OL	OL

IC27 : M30624FGFP (P.C.B. FUNCTION)
16 bit μ -COM (Main CPU)

No.	PORT	Name	I/O	Function	Power On	Power Off	Backup
85	P03	PRY	O	Power Relay	O	OL	OL
86	P02	VLRB	I	Volume B	I	I	OL
87	P01	VLRA	I	Volume A	I	I	OL
88	P00	PRI	I	I Protection	I	I	OL
89	AN7	MTER	AD	Tuner Meter	I	I	I
90	AN6		AD	Not used	I	I	I
91	AN5	KEY1	AD	Key State 1	I	I	I
92	AN4	KEY0	AD	Key State 0	I	I	I
93	AN3		AD	Not used	I	I	I
94	AN2	THM	AD	Thermal Detect	I	I	I
95	AN1	PRD	AD	DC Protection	I	I	I
96	AVSS	AVSS	VSS	Ground for AD	VSS	VSS	VSS
97	AN0	PRV	AD	V Protection	I	I	I
98	VREF	VREF	VCC	Reference voltage for AD	VCC	VCC	VCC
99	AVCC	AVCC	VCC	Power Supply for AD	VCC	VCC	VCC
100	P97		O	Not used	OL	OL	OL

(Note 1) Pin 61, 63 Tuner Mode 0 and 1

Tuner Mode 1	Tuner Mode 0	Tuner Frequency
0	0	AM : 531-1611kHz(9kHz step) FM : 76.0-90.0MHz(100kHz step)
0	1	AM : 530-1710kHz(10kHz step) FM : 87.5-107.9MHz(200kHz step)
1	0	AM : 531-1611kHz(9kHz step) FM : 87.5-108.0MHz(50kHz step)
1	1	DSP-AX1

IC1 : M30624FGFP (P.C.B. DSP)
16 bit μ -COM (Sub CPU)

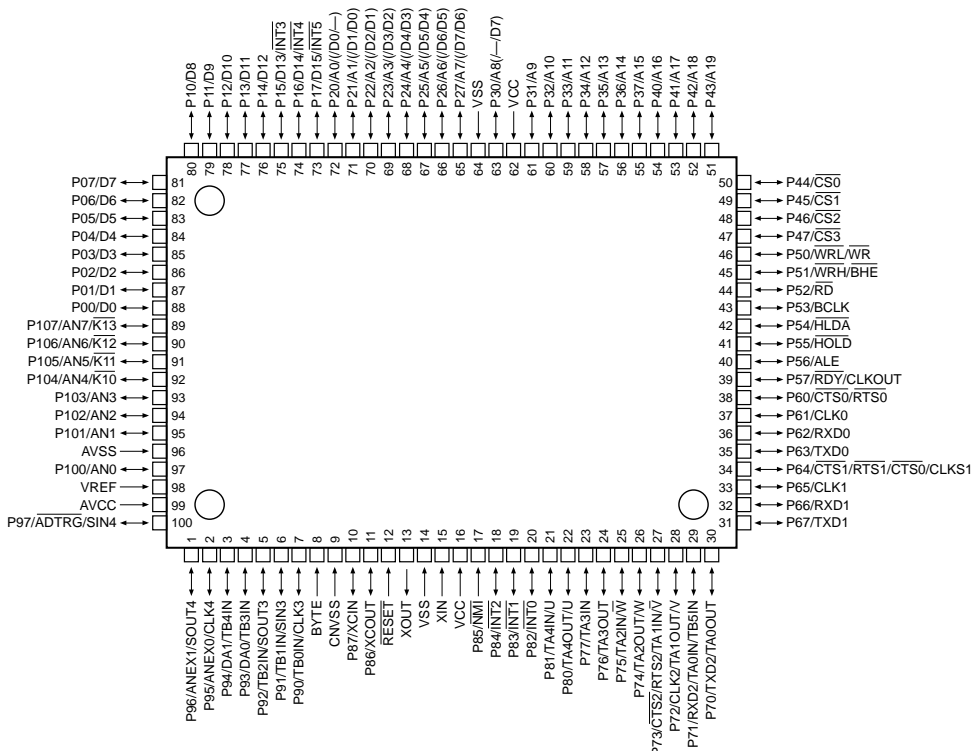

DSP-AX1/RX-V1

DSP-AX1/RX-V1

IC1 : M30624FGFP (P.C.B. DSP)
16 bit μ -COM (Sub CPU)

No.	PORT	Name	Function	I/O	No.	PORT	Name	Function	I/O
1	P96	/CSA2	CS for AC3D2av	O	51	P43	CA3	DSP6 Address Bus 3	O
2	P95	/CSA1	CS for AC3Dav	O	52	P42	CA2	DSP6 Address Bus 2	O
3	TB4IN	DBL	DIR5 Double Rate	I	53	P41	CA1	DSP6 Address Bus 1	O
4	P93	/CSD	CS for DIR5	O	54	P40	CA0	DSP6 Address Bus 0	O
5	SOUT	SDM	Tx for AC3Dav/AC3D2av/DIR5	TXD	55	P37	CD15	DSP6 Data Bus 15	I/O
6	SIN	SDD	Rx for AC3Dav/AC3D2av/DIR5	RXD	56	P36	CD14	DSP6 Data Bus 14	I/O
7	CLK3	SCK	CLK for AC3Dav/AC3D2av/DIR5	CLK	57	P35	CD13	DSP6 Data Bus 13	I/O
8	BYTE	BYTE	Single Chip Mode : VSS		58	P34	CD12	DSP6 Data Bus 12	I/O
9	CNVSS	CNVSS	Single Chip Mode : VSS, Flush Write : VCC		59	P33	CD11	DSP6 Data Bus 11	I/O
10	P87	NC	–	OL	60	P32	CD10	DSP6 Data Bus 10	I/O
11	P86	NC	–	OL	61	P31	CD9	DSP6 Data Bus 9	I/O
12	/RESET	/RST	Reset from Main	RST	62	VCC	VCC	+5V	
13	XOUT	XOUT	16MHz		63	P30	CD8	DSP6 Data Bus 8	I/O
14	VSS	GND	GND		64	VSS	VSS	GND	
15	XIN	XIN	16MHz		65	P27	CD7	DSP6 Data Bus 7	I/O
16	VCC	VCC	+5V		66	P26	CD6	DSP6 Data Bus 6	I/O
17	P85	/NMI	+5V	I	67	P25	CD5	DSP6 Data Bus 5	I/O
18	INT2	NPCM	AC3D2av Non PCM	IRQ	68	P24	CD4	DSP6 Data Bus 4	I/O
19	INT1	ERRA	AC3D2av Mute	IRQ	69	P23	CD3	DSP6 Data Bus 3	I/O
20	INT0	IRQD	DIR5 IRQ	IRQ	70	P22	CD2	DSP6 Data Bus 2	I/O
21	P81	NC	–	OL	71	P21	CD1	DSP6 Data Bus 1	I/O
22	P80	/ICD	IC for AC3Dav/DIR/DA/AD/DEM	O	72	P20	CD0	DSP6 Data Bus 0	I/O
23	P77	96SL	fs 96kHz Select (Hi : 96kHz)	O	73	INT5	/IRQ62	DSP6 #2 IRQ	IRQ
24	P76	/DMT	Digital Full Mute	O	74	P16		–	OL
25	P75	NC	–	OL	75	INT3	/IRQ61	DSP6 #1 IRQ	IRQ
26	P74	TRQ	CPU I/F Request	O	76	P14	/IC6	DSP6 Initial Clear	O
27	P73	MCWC	CPU I/F Word Clock	O	77	P13		–	OL
28	CLK2	MCBC	CPU I/F Bit Clock	CLK	78	P12		–	OL
29	RXD2	MTS	CPU I/F Main to Sub	RXD	79	P11		–	OL
30	TXD2	STM	CPU I/F Sub to Main	TXD	80	P10		–	OL
31	TXD1	TXFL	Tx for Flash	TXD	81	P07		–	OL
32	RXD1	RXFL	Rx for Flash	RXD	82	P06		–	OL
33	CLK1	CLKFL	CLK for Flash	CLK	83	P05		–	OL
34	RTS1	BSYFL	BUSY for Flash	RTS	84	P04		–	OL
35	P63		–	OL	85	P03		–	OL
36	P62		–	OL	86	P02		–	OL
37	P61		–	OL	87	P01		–	OL
38	P60		–	OL	88	P00		–	OL
39	P57	/WT62	DSP6 #2 Wait	I	89	P107		–	OL
40	P56	/WT61	DSP6 #1 Wait	I	90	P106		–	OL
41	P55	/EPM	GND for Flash	I	91	P105		–	OL
42	P54	/CS62	DSP6 #2 Chip Select	O	92	P104	MUTO	RF DEM MUTO	I
43	P53	/CS61	DSP6 #1 Chip Select	O	93	P103	CXCA	CABLE Coaxial	I
44	P52	/WR6	DSP6 Write Enable	O	94	P102	CXDV	DVD Coaxial	I
45	P51	/RD6	DSP6 Read Enable	O	95	P101	CXCD	CD Coaxial	I
46	P50	/CE	+5V for Flash	I	96	AVSS	AVSS	GND for Analog	I
47	P47	CA7	DSP6 Address Bus 7	O	97	AN0		–	AD
48	P46	CA6	DSP6 Address Bus 6	O	98	VREF	VREF	Reference voltage for AD	
49	P45	CA5	DSP6 Address Bus 5	O	99	AVCC	AVCC	Power supply for Analog	
50	P44	CA4	DSP6 Address Bus 4	O	100	P97	/CSAS	CS for AC3D2av Sub DSP	O

DSP-AX1/RX-V1

IC2 : YSD917 (P.C.B. DSP)
DIR5 (Digital Format Interface Receiver)

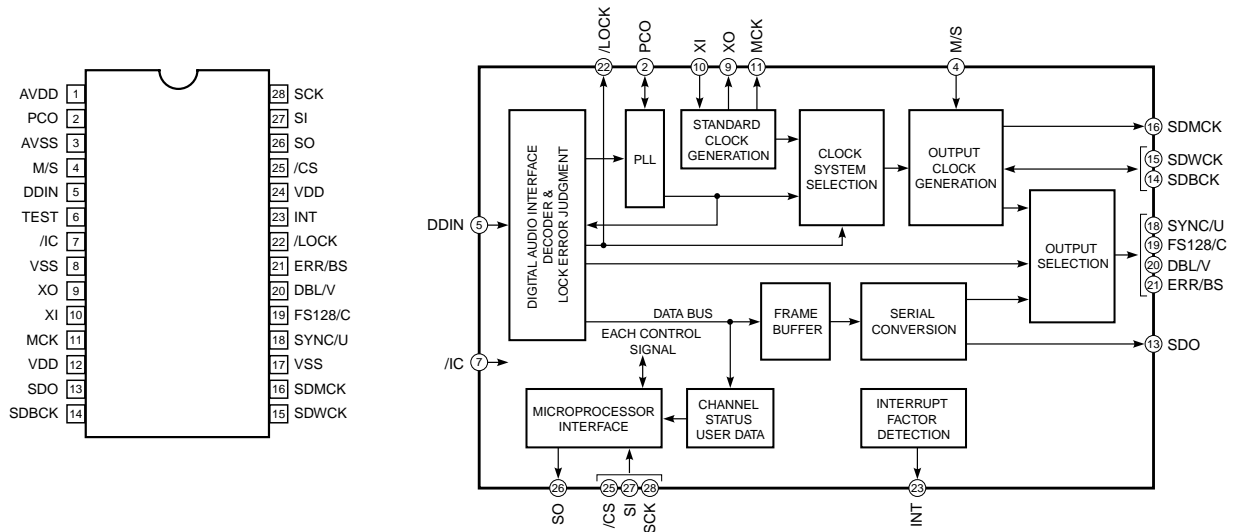

No.	Name	I/O	Function
1	AVDD		Analog power supply for PLL (+5V)
2	PCO	A	PLL filter connecting terminal
3	AVSS		Analog ground
4	M/S	Is+	Master/slave mode selection
5	DDIN	Is	Digital audio interface data input
6	TEST	Is+	Test terminal (to be open)
7	/IC	Is	Initial clear input
8	VSS		Ground
9	XO	O	24.576MHz crystal oscillator connecting terminal (output)
10	XI	I	24.576MHz crystal oscillator connecting terminal (input)
11	MCK	O	12.288MHz clock output terminal
12	VDD		+5V power supply
13	SDO	O	Serial data output
14	SDBCK	Is/O	Serial data bit clock input/output 64fs
15	SDWCK	I/O	Serial data word clock input/output fs
16	SDMCK	O	Serial data master clock output 256fs or 128fs
17	VSS		Ground
18	SYNC/U	O	Serial data synchronous timing output / user data output
19	FS128/C	O	Serial data master clock 128fs output / channel status output
20	DBL/V	O	Double rate clock output / validity flag output
21	ERR/BS	O	Data error detect output / block start output
22	/LOCK	O	PLL lock detect output
23	INT	O	Interrupt output
24	VDD		+5V power supply
25	/CS	I	Microprocessor interface chip select input
26	SO	Ot	Microprocessor interface data output
27	SI	I	Microprocessor interface data input
28	SCK	Is	Microprocessor interface bit clock input

Is: Schmidt trigger input terminal
 I+: Input terminal with pull-up resistor
 O: digital output terminal
 Ot: Tri-state digital output terminal
 A: Analog terminal

With SYNC/U, FS128, DBL/V and ERR/BS, select each function by setting the control register.

DSP-AX1/RX-V1

IC5 : YSS908-F (P.C.B. DSP)
AC3Dav

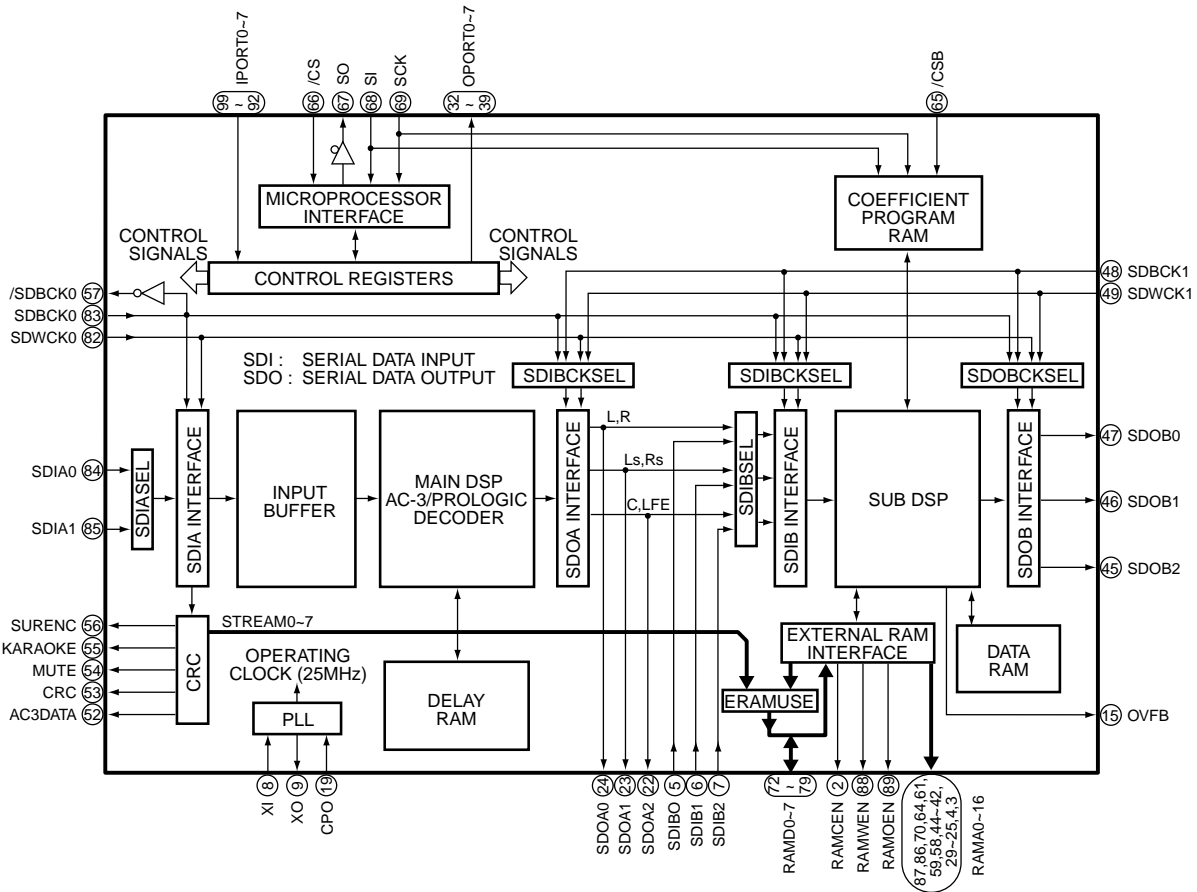
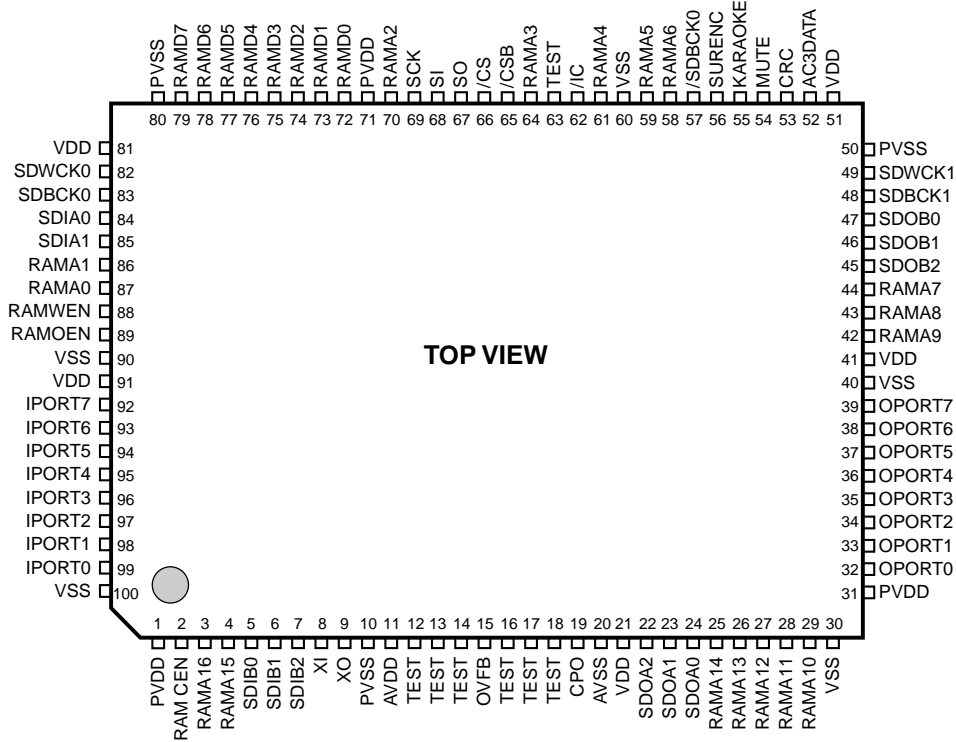

DSP-AX1/RX-V1

IC5 : YSS908 (P.C.B. DSP)
AC3Dav

No.	Name	I/O	Function
1	PVDD		+5V power supply
2	RAMCEN	O	External SRAM chip enable terminal
3	RAMA16	O	External SRAM address terminal 16
4	RAMA15	O	External SRAM address terminal 15
5	SDIB0	I	PCM input terminal 0 to Sub DSP
6	SDIB1	I	PCM input terminal 1 to Sub DSP
7	SDIB2	I	PCM input terminal 2 to Sub DSP
8	XI	I	Crystal oscillator connecting terminal (12.288MHz)
9	XO	O	Crystal oscillator connecting terminal
10	PVSS		Ground terminal (for digital)
11	AVDD		+3V power terminal (for analog)
12	TEST		Test terminal (unconnected)
13	TEST		Test terminal (unconnected)
14	TEST		Test terminal (unconnected)
15	OVFB	O	Sub DSP overflow detect terminal
16	TEST		Test terminal (unconnected)
17	TEST		Test terminal (unconnected)
18	TEST		Test terminal (unconnected)
19	CPO	O	PLL output terminal (connected to external analog filter circuit)
20	AVSS		Ground terminal (for PLL circuit)
21	VDD2		+3.3V power terminal (for internal circuit)
22	SDOA2	O	PCM output terminal from Main DSP (C/LFE output at AC-3/DTS, C/S output at Pro Logic)
23	SDOA1	O	PCM output terminal from Main DSP (LS/RS output at AC-3/DTS, Lt/Rt output at Pro Logic)
24	SDOA0	O	PCM output terminal from Main DSP (L/R output at both AC-3/DTS and Pro Logic)
25	RAMA14	O	External SRAM address terminal 14
26	RAMA13	O	External SRAM address terminal 13
27	RAMA12	O	External SRAM address terminal 12
28	RAMA11	O	External SRAM address terminal 11
29	RAMA10	O	External SRAM address terminal 10
30	VSS		Ground terminal (for internal circuit)
31	PVDD		+5V power terminal
32	OPORT0	O	General purpose output terminal (L/R ch is shifted by +3dB at Dolby Pro Logic)
33	OPORT1	O	General purpose output terminal (N.C.)
34	OPORT2	O	General purpose output terminal (N.C.)
35	OPORT3	O	General purpose output terminal (N.C.)
36	OPORT4	O	General purpose output terminal (N.C.)
37	OPORT5	O	General purpose output terminal (N.C.)
38	OPORT6	O	General purpose output terminal (N.C.)
39	OPORT7	O	General purpose output terminal (N.C.)
40	VSS		Ground terminal (for internal circuit)
41	VDD		+3V power terminal
42	RAMA9	O	External SRAM address terminal 9
43	RAMA8	O	External SRAM address terminal 8
44	RAMA7	O	External SRAM address terminal 7
45	SDOB2	O	PCM output terminal from Sub DSP
46	SDOB1	O	PCM output terminal from Sub DSP
47	SDOB0	O	PCM output terminal from Sub DSP
48	SDBCK1	I	Bit clock input terminal for SDOA, SDIB, SDOB signals
49	SDWCK1	I	Word clock input terminal for SDOA, SDIB, SDOB signals
50	VSS		Ground terminal
51	VDD		+3V power terminal
52	AC3DATA	O	AC-3 data output terminal, AC-3 bit stream data detect

DSP-AX1/RX-V1

DSP-AX1/RX-V1

**IC5 : YSS908 (P.C.B. DSP)
AC3Dav**

No.	Name	I/O	Function
53	CRC	O	AC-3 CRC error detect terminal
54	MUTE	O	Auto mute detect terminal
55	KARAOKE	O	AC-3 KARAOKE data detect terminal
56	SURENC	O	AC-3 2/0 mode Dolby surround encode input detect terminal
57	/SDBCK0	O	SDBCK0 invert clock output terminal
58	RAMA6	O	External SRAM address terminal 6
59	RAMA5	O	External SRAM address terminal 5
60	VSS		Ground terminal
61	RAMA4	O	External SRAM address terminal 4
62	/IC	I	Initial clear terminal
63	TEST		Test terminal (unconnected)
64	RAMA3	O	External SRAM address terminal 3
65	/CSB	I	Sub DSP chip select input terminal
66	/CS	I	Microprocessor interface chip select input terminal
67	SO	O	Microprocessor interface data output terminal
68	SI	I	Microprocessor interface and Sub DSP data input terminal
69	SCK	I	Microprocessor interface and Sub DSP clock input terminal
70	RAMA2	O	External SRAM address terminal 2
71	PVDD		+5V power terminal
72	RAMD0	I/O	External SRAM data terminal (STREAM 0 output when external SRAM is not used)
73	RAMD1	I/O	External SRAM data terminal (STREAM 1 output when external SRAM is not used)
74	RAMD2	I/O	External SRAM data terminal (STREAM 2 output when external SRAM is not used)
75	RAMD3	I/O	External SRAM data terminal (STREAM 3 output when external SRAM is not used)
76	RAMD4	I/O	External SRAM data terminal (STREAM 4 output when external SRAM is not used)
77	RAMD5	I/O	External SRAM data terminal (STREAM 5 output when external SRAM is not used)
78	RAMD6	I/O	External SRAM data terminal (STREAM 6 output when external SRAM is not used)
79	RAMD7	I/O	External SRAM data terminal (STREAM 7 output when external SRAM is not used)
80	PVSS		Ground terminal
81	VDD2		+3V power terminal
82	SDWCK0	I	Word clock input terminal for SDIA, SDOA, SDIB and SDOB signals
83	SDBCK0	I	Bit clock input terminal for SDIA, SDOA, SDIB and SDOB signals
84	SDIA0	I	AC-3/DTS bit stream (or PCM) data input terminal to Main DSP
85	SDIA1	I	AC-3/DTS bit stream (or PCM) data input terminal to Main DSP
86	RAMA1	O	External SRAM address terminal 1
87	RAMA0	O	External SRAM address terminal 0
88	RAMWEN	O	External SRAM write enable terminal
89	RAMOEN	O	External SRAM output enable terminal
90	VSS		Ground terminal
91	VDD		+3V power terminal
92	IPORT7	I	General purpose input terminal (GND)
93	IPORT6	I	General purpose input terminal (GND)
94	IPORT5	I	General purpose input terminal (GND)
95	IPORT4	I	General purpose input terminal (GND)
96	IPORT3	I	General purpose input terminal (GND)
97	IPORT2	I	General purpose input terminal (GND)
98	IPORT1	I	General purpose input terminal (GND)
99	IPORT0	I	General purpose input terminal (GND)
100	VSS		Ground terminal

DSP-AX1/RX-V1

DSP-AX1/RX-V1

**IC6 : YSS918 (P.C.B. DSP)
AC3D2av**

No.	Name	I/O	Function
1	VDD		+5V power supply (for terminal section)
2	RAMCEN	O	External SRAM chip enable terminal
3	RAMA16	O	External SRAM address terminal 16
4	RAMA15	O	External SRAM address terminal 15
5	SDIB0	Itp	PCM input terminal 0 to Sub DSP
6	SDIB1	Itp	PCM input terminal 1 to Sub DSP
7	SDIB2	Itp	PCM input terminal 2 to Sub DSP
8	XI	Ic	Crystal oscillator connecting terminal (12.288MHz)
9	XO	O	Crystal oscillator connecting terminal
10	VSS		Ground terminal (for terminal section)
11	AVDD		+3.3V power terminal (for PLL circuit)
12	SDIB3	Itp	PCM input terminal 3 to Sub DSP
13	TEST		Test terminal (unconnected)
14	TEST		Test terminal (unconnected)
15	OVFB	O	Sub DSP overflow detect terminal
16	DTSDATA	O	DTS data detect terminal
17	AC3DATA	O	AC-3 data detect terminal
18	SDOB3	O	PCM output terminal from Sub DSP
19	CPO	A	PLL output terminal (connected to external analog filter circuit)
20	AVSS		Ground terminal (for PLL circuit)
21	VDD2		+3.3V power terminal (for internal circuit)
22	SDOA2	O	PCM output terminal from Main DSP (C/LFE output at AC-3/DTS, C/S output at Pro Logic)
23	SDOA1	O	PCM output terminal from Main DSP (LS/RS output at AC-3/DTS, Lt/Rt output at Pro Logic)
24	SDOA0	O	PCM output terminal from Main DSP (L/R output at both AC-3/DTS and Pro Logic)
25	RAMA14	O	External SRAM address terminal 14
26	RAMA13	O	External SRAM address terminal 13
27	RAMA12	O	External SRAM address terminal 12
28	RAMA11	O	External SRAM address terminal 11
29	RAMA10	O	External SRAM address terminal 10
30	VSS		Ground terminal (for internal circuit)
31	VDD1		+5V power terminal (for terminal section)
32	OPORT0	O	General purpose output terminal (ISL0 : DIGITAL INPUT SEL)
33	OPORT1	O	General purpose output terminal (ISL1 : DIGITAL INPUT SEL)
34	OPORT2	O	General purpose output terminal (ISL2 : DIGITAL INPUT SEL)
35	OPORT3	O	General purpose output terminal (RFSL : LD RF INPUT SEL)
36	OPORT4	O	General purpose output terminal (RSL0 : DIGITAL REC OUT SEL)
37	OPORT5	O	General purpose output terminal (RSL1 : DIGITAL REC OUT SEL)
38	OPORT6	O	General purpose output terminal (RSL2 : DIGITAL REC OUT SEL)
39	OPORT7	O	General purpose output terminal (ADSL : AD INPUT SEL)
40	VSS		Ground terminal (for internal circuit)
41	VDD2		+3.3V power terminal (for internal circuit)
42	RAMA9	O	External SRAM address terminal 9
43	RAMA8	O	External SRAM address terminal 8
44	RAMA7	O	External SRAM address terminal 7
45	SDOB2	O	PCM output terminal from Sub DSP
46	SDOB1	O	PCM output terminal from Sub DSP
47	SDOB0	O	PCM output terminal from Sub DSP
48	SDBCK1	Itp	Bit clock input terminal for SDOA, SDIB, SDOB signals
49	SDWCK1	Itp	Word clock input terminal for SDOA, SDIB, SDOB signals
50	VSS		Ground terminal (for terminal section)
51	VDD2		+3.3V power terminal (for internal circuit)
52	NONPCM	O	Non-PCM data detect terminal

IC6 : YSS918 (P.C.B. DSP)
AC3D2av

No.	Name	I/O	Function
53	CRC	O	AC-3 CRC error detect terminal
54	MUTE	O	Auto mute detect terminal
55	KARAOKE	O	AC-3 KARAOKE data detect terminal
56	SURENC	O	AC-3 2/0 mode Dolby surround encode input detect terminal
57	/SDBCK0	O	SDBCK0 invert clock output terminal
58	RAMA6	O	External SRAM address terminal 6
59	RAMA5	O	External SRAM address terminal 5
60	VSS		Ground terminal (for internal circuit)
61	RAMA4	O	External SRAM address terminal 4
62	/IC	Ics	Initial clear terminal
63	TEST		Test terminal (unconnected)
64	RAMA3	O	External SRAM address terminal 3
65	/CSB	ltsp	Sub DSP chip select input terminal
66	/CS	Its	Microprocessor interface chip select input terminal
67	SO	O*	Microprocessor interface data output terminal
68	SI	Its	Microprocessor interface and Sub DSP data input terminal
69	SCK	Its	Microprocessor interface and Sub DSP clock input terminal
70	RAMA2	O	External SRAM address terminal 2
71	VDD1		+5V power terminal (for terminal section)
72	RAMD0	Itp/O	External SRAM data terminal (STREAM 0 output when external SRAM is not used)
73	RAMD1	Itp/O	External SRAM data terminal (STREAM 1 output when external SRAM is not used)
74	RAMD2	Itp/O	External SRAM data terminal (STREAM 2 output when external SRAM is not used)
75	RAMD3	Itp/O	External SRAM data terminal (STREAM 3 output when external SRAM is not used)
76	RAMD4	Itp/O	External SRAM data terminal (STREAM 4 output when external SRAM is not used)
77	RAMD5	Itp/O	External SRAM data terminal (STREAM 5 output when external SRAM is not used)
78	RAMD6	Itp/O	External SRAM data terminal (STREAM 6 output when external SRAM is not used)
79	RAMD7	Itp/O	External SRAM data terminal (STREAM 7 output when external SRAM is not used)
80	VSS		Ground terminal (for terminal section)
81	VDD2		+3.3V power terminal (for internal circuit)
82	SDWCK0	It	Word clock input terminal for SDIA, SDOA, SDIB and SDOB signals
83	SDBCK0	It	Bit clock input terminal for SDIA, SDOA, SDIB and SDOB signals
84	SDIA0	It	AC-3/DTS bit stream (or PCM) data input terminal to Main DSP
85	SDIA1	It	AC-3/DTS bit stream (or PCM) data input terminal to Main DSP
86	RAMA1	O	External SRAM address terminal 1
87	RAMA0	O	External SRAM address terminal 0
88	RAMWEN	O	External SRAM write enable terminal
89	RAMOEN	O	External SRAM output enable terminal
90	VSS		Ground terminal
91	VDD2		+3.3V power terminal (for internal circuit)
92	IPORT7	Itp	General purpose input terminal (Used for IC YSS908/918 identification: +3.3V)
93	IPORT6	Itp	General purpose input terminal (GND)
94	IPORT5	Itp	General purpose input terminal (GND)
95	IPORT4	Itp	General purpose input terminal (GND)
96	IPORT3	Itp	General purpose input terminal (GND)
97	IPORT2	Itp	General purpose input terminal (GND)
98	IPORT1	Itp	General purpose input terminal (GND)
99	IPORT0	Itp	General purpose input terminal (GND)
100	VSS		Ground terminal

Note) Listed below are symbols in the I/O column and their meanings.

Ic: CMOS level input terminal

It: TTL level input terminal

Is: Schmidt trigger input terminal

Ip: Input terminal with pull-up resistor

O: Digital output terminal

O*: Tri-state digital output terminal

A: Analog input terminal

DSP-AX1/RX-V1

IC7, 8 : YSS910-S
 DSP6 (Digital Audio Processor)

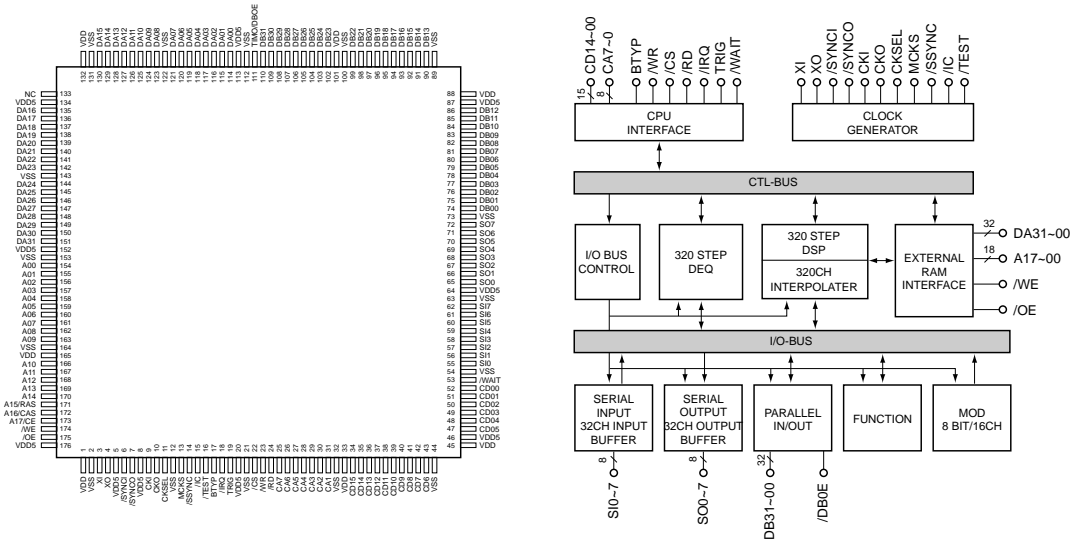

Name	I/O	Function
XI	I	System master clock input (60MHz or 30MHz)
XO	O	System master clock output (60MHz or 30MHz)
/SYNCI	I	System synchronous signal input
CKI	I	System clock input (30MHz)
/SYNCO	O	System synchronous signal output
CKO	O	System clock output (30MHz)
CKSEL	I	System master clock select (0:60MHz, 1: 30MHz)
MCKS	I	Master clock input for serial I/O (128 x Fs)
/SSYNC	I	Synchronous signal input for serial I/O
/IC	Is	Initial clear
/TEST	I+	Test mode setting (0: Test, 1: Normal)
CD14-00	I/O	Host CPU data bus
CA0/CD15	I/O	Host CPU address bus / data bus
CA7-1	I	Host CPU address bus
BTYP	I	Host CPU data bus width select (0: 8 bit, 1: 16 bit)
/CS	Is+	Chip select signal input
/RD	Is+	Read signal input
/WR	Is+	Write signal input
/IRQ	O	IRQ output
TRIG	I/O	Transfer trigger signal input/output
/WAIT	O	WAIT output
SI7-0	I+	Serial data input
SO7-0	O	Serial data output
DBE31-00	I+/O	Parallel data bus
TIMO/DBOE	I/O	Timing signal output / parallel data bus output control input
DA31-00	I+/O	External memory data bus
A17/CE	O	External memory address (SRAM), /CE (PSRAM)
A16/CAS	O	External memory address (SRAM, PSRAM), /CAS (DRAM)
A15/RAS	O	External memory address (SRAM, PSRAM), /RAS (DRAM)
A14-12	O	External memory address (SRAM, PSRAM)
A11-00	O	External memory address (SRAM, PSRAM, DRAM)
/WE	O	External memory Write Enable signal
/OE	O	External memory Output Enable signal
(N.C.)	-	No connection
VDD5	-	+5V
VDD	-	+3.3V
VSS	-	Ground

DSP-AX1/RX-V1

IC24 : PM4007A (P.C.B. DSP)
AC-3 RF Demodulator

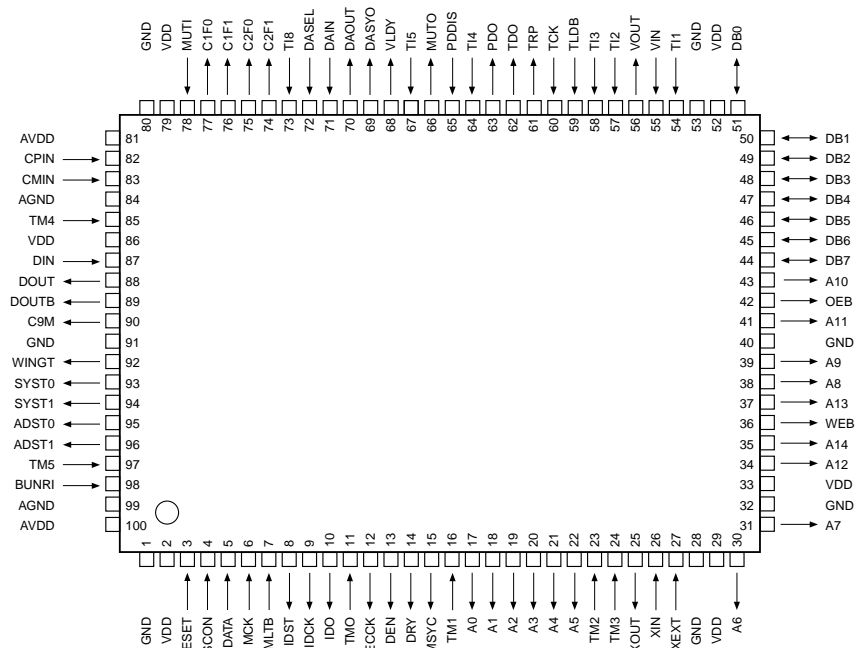

No.	Name	I/O	Function
1	GND		Ground (0V)
2	VDD		+5V power supply
3	RESET	I	System resetting terminal (reset at "L")
4	OSCON	I	Oscillation control terminal. Oscillation ON at "H", set to "H" normally and to "L" when in standby state
5	DATA	I	IC test terminal, normally connected to ground (or unconnected)
6	MCK	I	IC test terminal, normally connected to ground (or unconnected)
7	MLTB	I	IC test terminal, normally connected to ground (or unconnected)
8	IDST	O	Output terminal for IC test
9	IDCK	O	Output terminal for IC test
10	IDO	O	Output terminal for IC test
11	TMO	I	IC test terminal, normally connected to ground (or unconnected)
12	ECCK	O	Output terminal for IC test
13	DEN	O	Output terminal for IC test
14	DRY	O	Output terminal for IC test
15	MSYC	O	Output terminal for IC test
16	TM1	I	IC test terminal, normally connected to ground (or unconnected)
17	A0	O	External RAM address output. Address 0 (LSB)
18	A1	O	External RAM address output. Address 1
19	A2	O	External RAM address output. Address 2
20	A3	O	External RAM address output. Address 3
21	A4	O	External RAM address output. Address 4
22	A5	O	External RAM address output. Address 5
23	TM2	I	IC test terminal, normally connected to ground (or unconnected)
24	TM3	I	IC test terminal, normally connected to ground (or unconnected)
25	XOUT	O	Output terminal for IC test
26	XIN	I	IC test terminal, normally connected to ground (or unconnected)
27	XEXT	I	IC test terminal, normally connected to ground (or unconnected)
28	GND		Ground terminal (0V)
29	VDD		+5V power supply

IC24 : PM4007A (P.C.B. DSP)
AC-3 RF Demodulator

No.	Name	I/O	Function
30	A6	O	External RAM address output. Address 6
31	A7	O	External RAM address output. Address 7
32	GND		Ground terminal (0V)
33	VDD		+5V power supply
34	A12	O	External RAM address output. Address 12
35	A14	O	External RAM address output. Address 14 (MSB)
36	WEB	O	External RAM write enable signal, active at "L"
37	A13	O	External RAM address output. Address 13
38	A8	O	External RAM address output. Address 8
39	A9	O	External RAM address output. Address 9
40	GND		Ground terminal (0V)
41	A11	O	External RAM address output. Address 11
42	OEB	O	External RAM output enable signal, active at "L"
43	A10	O	External RAM address output. Address 10
44	DB7	I/O	External RAM data terminal. Data bus 7
45	DB6	I/O	External RAM data terminal. Data bus 6
46	DB5	I/O	External RAM data terminal. Data bus 5
47	DB4	I/O	External RAM data terminal. Data bus 4
48	DB3	I/O	External RAM data terminal. Data bus 3
49	DB2	I/O	External RAM data terminal. Data bus 2
50	DB1	I/O	External RAM data terminal. Data bus 1
51	DB0	I/O	External RAM data terminal. Data bus 0
52	VDD		+5V power supply
53	GND		Ground terminal (0V)
54	TI1	I	IC test terminal, normally connected to VDD
55	VIN	I	VCXO input
56	VOUT	O	VCXO output
57	TI2	I	IC test terminal, normally connected to GND (or unconnected)
58	TI3	I	IC test terminal, normally connected to GND (or unconnected)
59	TLDB	I	IC test terminal, normally connected to GND (or unconnected)
60	TCK	I	IC test terminal, normally connected to GND (or unconnected)
61	TRP	O	Output terminal for IC test
62	TDO	O	Output terminal for IC test
63	PDO	O	Output terminal for phase comparator (tri-state)
64	TI4	I	IC test terminal, normally connected to GND (or unconnected)
65	PDDIS	I	Input terminal to control PDO output. Output ON at "L"
66	MUTO	O	Muting output. Muting available at "H". Setting becomes "H" when "MUTI=H" or AC-3 is asynchronous.
67	TI5	I	IC test terminal, normally connected to GND (or unconnected)
68	VLDY	O	Output terminal for IC test
69	DASYO	O	Output terminal for IC test
70	DAOUT	O	Digital out output (serial data stream output)
71	DAIN	I	Digital external input, through to DAOUT when DASEL is "H".
72	DASEL	I	Digital out select
73	TI8	I	IC test terminal, normally connected to GND (or unconnected)
74	C2F1	O	Terminal used to indicate error condition after C2 correction, whether completely corrected or not.
75	C2F0	O	Terminal used to indicate error condition after C2 correction, number of errors at C2.
76	C1F1	O	Terminal used to indicate error condition after C1 correction, whether any error exists at C1 or not.
77	C1F0	O	Terminal used to indicate error condition after C1 correction, number of errors at C1.
78	MUTI	I	Muting input. Muting available at "H"
79	VDD		+5V power supply
80	GND		Ground terminal (0V)

**IC24 : PM4007A (P.C.B. DSP)
AC-3 RF Demodulator**

No.	Name	I/O	Function
81	AVDD		+5V power supply for analog comparator
82	CPIN	I	Analog comparator input, positive side (Non-reverse side: QPSK input)
83	CMIN	I	Analog comparator input, negative side (reverse side)
84	AGND		Ground terminal for analog comparator (0V)
85	TM4	I	IC test terminal, normally connected to GND (or unconnected)
86	VDD		+5V power supply
87	DIN	I	IC test terminal, normally connected to GND (or unconnected)
88	DOUT	O	Analog comparator result output
89	DOUTB	O	Analog comparator result reverse output
90	C9M	O	9.216MHz output, output divided into 2 at VIN (No.55 pin)
91	GND		Ground terminal (0V)
92	WINGT	O	Output for IC test
93	SYST0	O	Output for IC test
94	SYST1	O	Output for IC test
95	ADST0	O	Output for IC test
96	ADST1	O	Output for IC test
97	TM5	I	IC test terminal, normally connected to GND (or unconnected)
98	BUNRI	I	IC test terminal, normally connected to GND (or unconnected)
99	AGND		Ground terminal (0V) for 46.08MHz oscillator
100	AVDD		+5V power supply for 46.08MHz oscillator

DSP-AX1/RX-V1

IC12 : M35013-079SP (P.C.B. VIDEO)
Superimpose

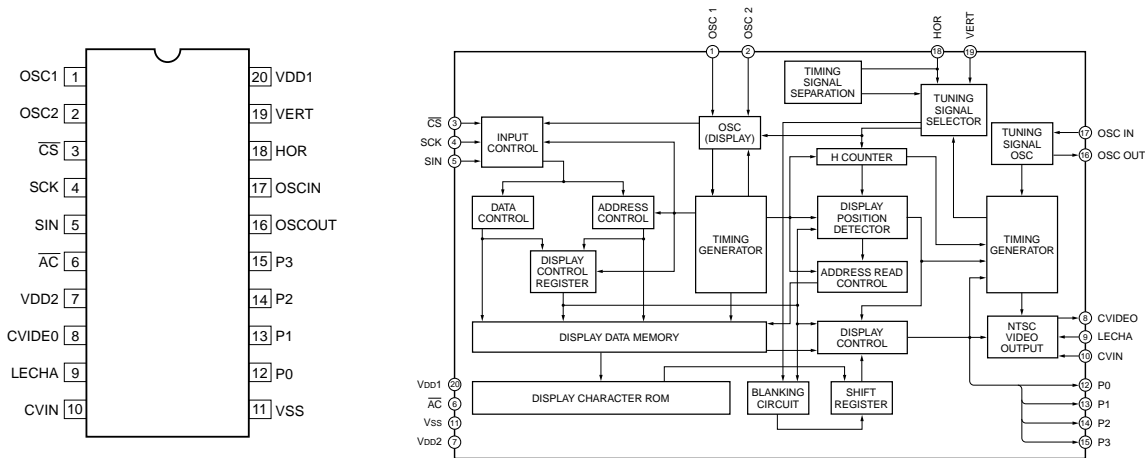

Pin No.	Symbol	Terminal name	Function
1 2	OSC1 OSC2	External terminal for oscillation circuit	External terminal of oscillation circuit for display. The standard oscillation frequency is about 7MHz. The display position in the horizontal direction and width of characters on the TV screen are determined according to this oscillation frequency.
3	\overline{CS}	Chip select input	Chip select terminal "L" is set when the serial data is transferred. Hysteresis input. A pull-up resistor is built in.
4	SCK	Serial clock input	When \overline{CS} terminal is "L", the SIN serial data is taken in at the SCK rise. Hysteresis input. A pull-up resistor is built in.
5	SIN	Serial data input	The data and addresses for the display control register and display data memory are input in serial form. Hysteresis input. A pull-up resistor is built in.
6	\overline{AC}	Auto clear input	The IC internal circuit is reset when in "L" state. Hysteresis input. A pull-up resistor is built in.
7	VDD2	Power supply terminal	Analog type power supply terminal that should be connected to +5V.
8	CVIDEO	Composite video signal output	Output terminal for composite video signal 2Vp-p composite video signal is output. When making a superimposition, the character output and other features are superimposed on the composite video signals input through the CVIN terminal.
9	LECHA	Character level input	Input terminal to determine the output level for the characters in the composite video signals. The color of characters is white.
10	CVIN	Video input	Input terminal for external composite video signals. When making a superimposition, the character output and other features are superimposed on these composite video signals.
11	VSS	Ground terminal	Connection to GND is made by using this terminal.
12	P0	Port 0 output	Port terminal output or character background signals (BLNK1*) are output. The polarity can be selected when determining the font ROM.
13	P1	Port 1 output	Port terminal output or character background signals (CO1*) are output. The polarity can be selected when determining the font ROM.
14	P2	Port 2 output	Port terminal output or character background signals (BLNK2*) are output. The polarity can be selected when determining the font ROM.
15	P3	Port 3 output	Port terminal output or character background signals (CO2*) are output. The polarity can be selected when determining the font ROM.
16 17	OSCOUT OSCIN	Oscillation circuit for generation of synchronous signals	External terminal of the oscillation circuit for generation of synchronous signals. The oscillation frequency is 14.32MHz when the NTSC system is used and 17.73MHz when the PAL system is used.
18	HOR*	Horizontal synchronous signal input	Horizontal synchronous signals are input. Hysteresis input The polarity can be selected when determining the font ROM.
19	VERT*	Vertical synchronous signal input	Vertical synchronous signals are input. Hysteresis input The polarity can be selected when determining the font ROM.
20	VDD1	Power supply terminal	Digital type power supply terminal that should be connected to +5V.

■ BLOCK DIAGRAM

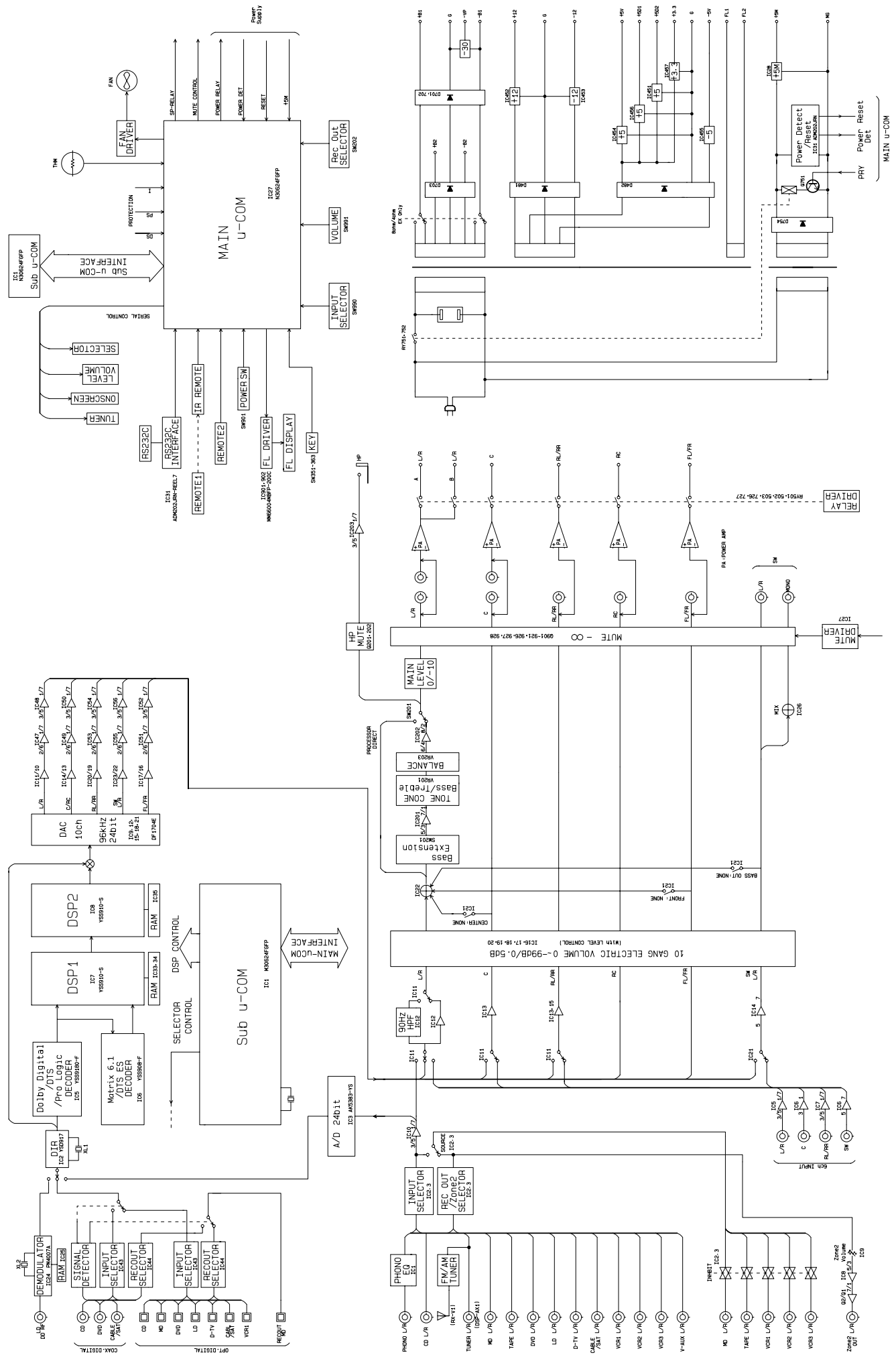

BLOCK DIAGRAM

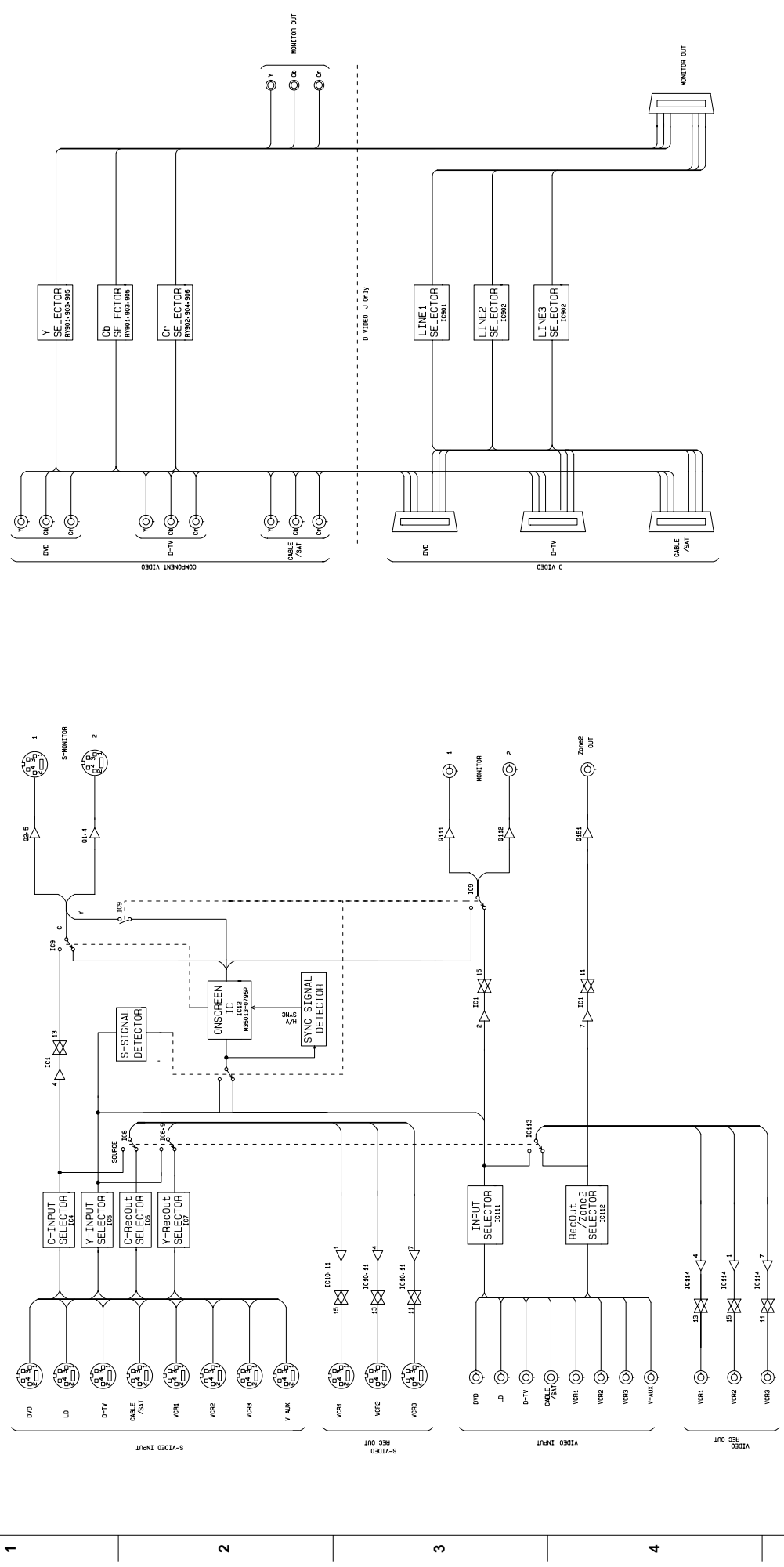

1

2

3

4

5

6

■ BLOCK DIAGRAM (TUNER : RX-V1 only)

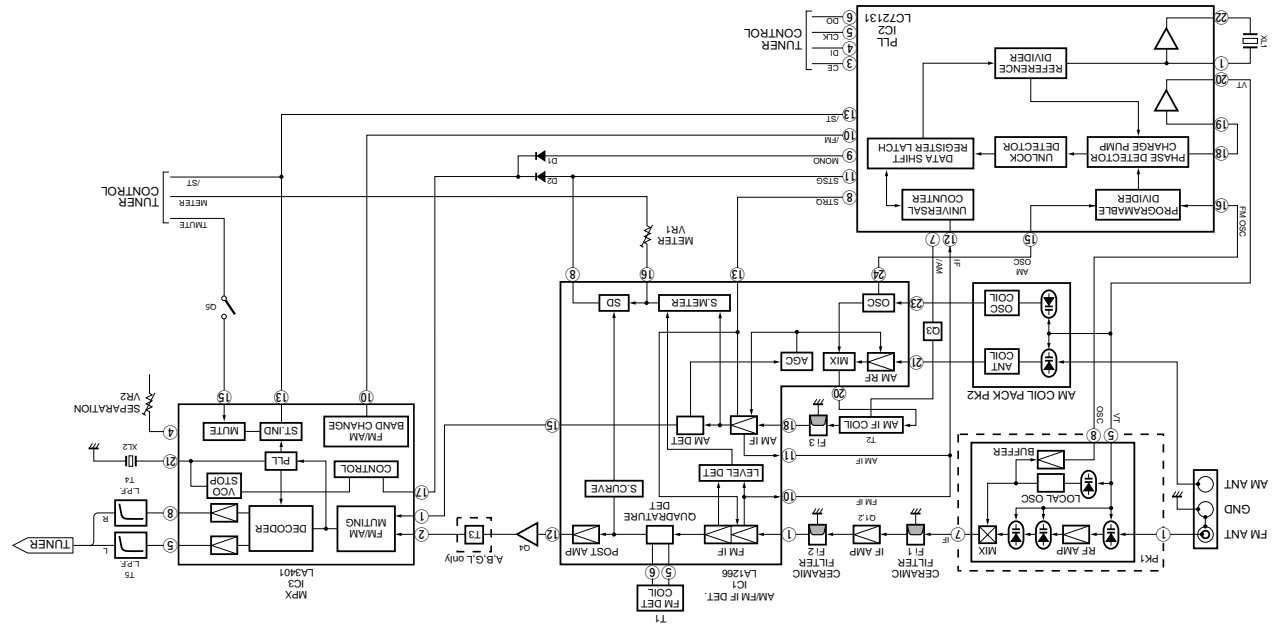

■ PIN CONNECTION DIAGRAM

● ICs

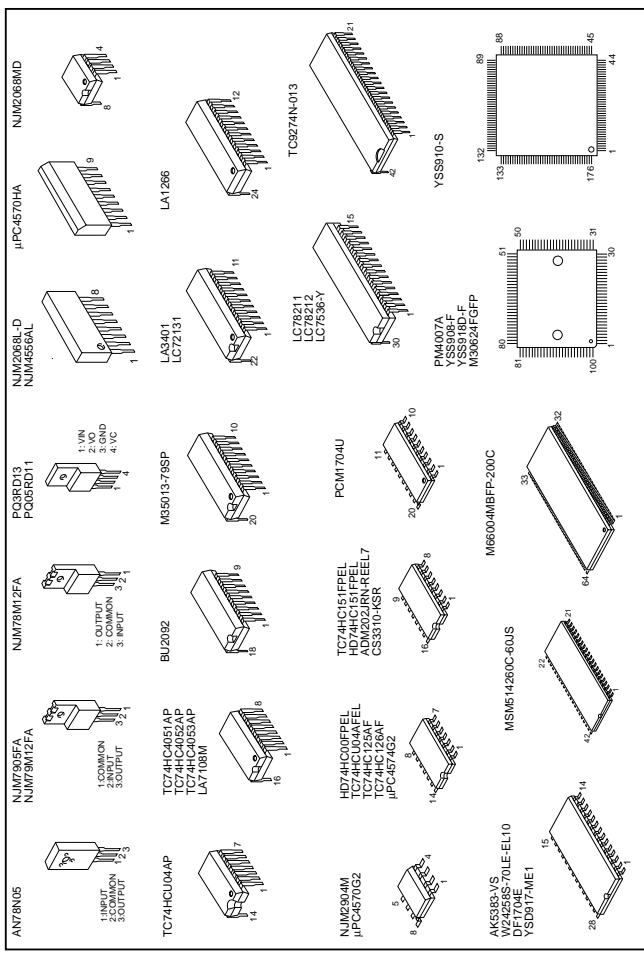

● Transistors

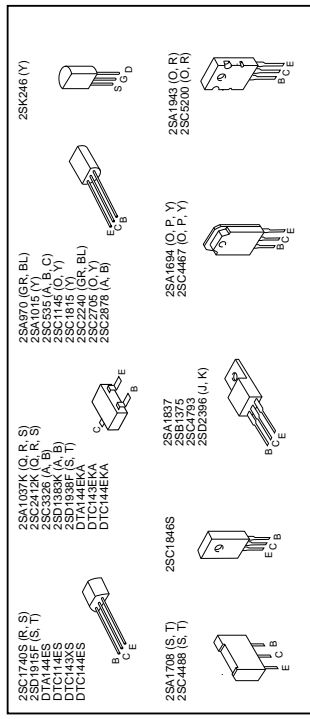

● Diodes

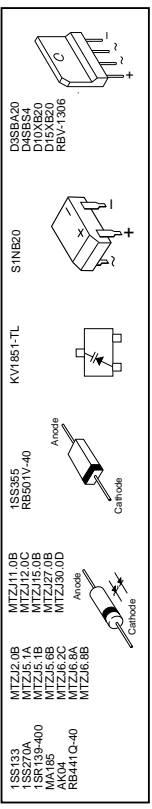

SCHEMATIC DIAGRAM (DSP1-1)

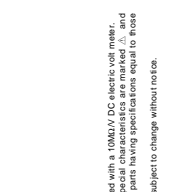
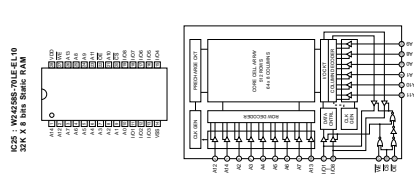
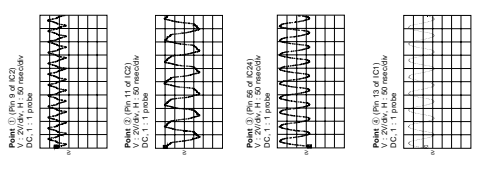
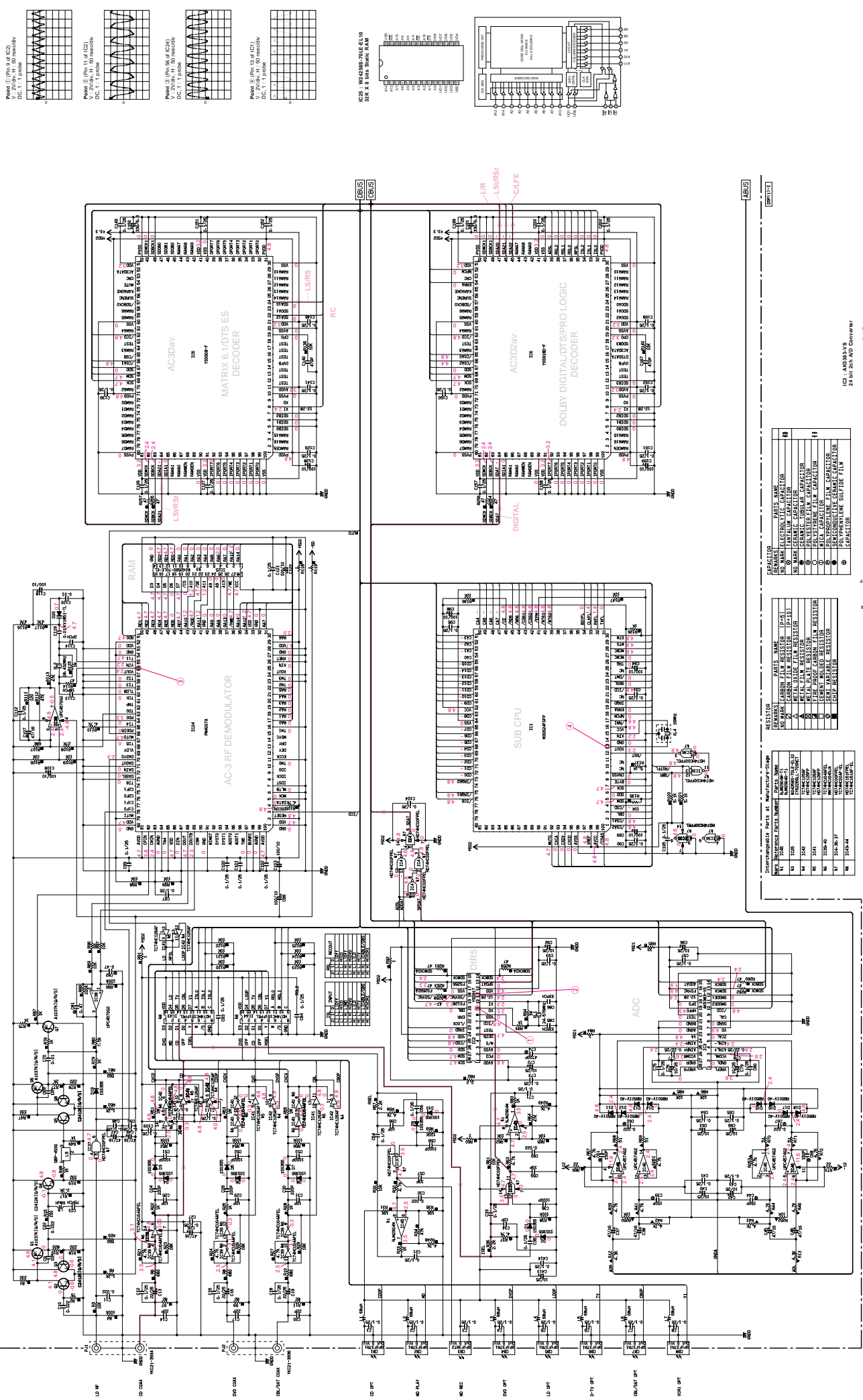

IC3: 1024 x 16 DRAM RAM

REF	PARTS NAME	QTY
1	1024 X 16 DRAM RAM	1

IC4: 1024 x 16 DRAM RAM

REF	PARTS NAME	QTY
1	1024 X 16 DRAM RAM	1

IC5: 44100 Hz S/PK Filter

REF	PARTS NAME	QTY
1	44100 Hz S/PK Filter	1

IC6: 44100 Hz S/PK Filter

REF	PARTS NAME	QTY
1	44100 Hz S/PK Filter	1

IC7: 44100 Hz S/PK Filter

REF	PARTS NAME	QTY
1	44100 Hz S/PK Filter	1

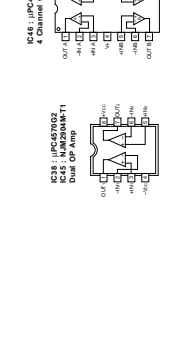
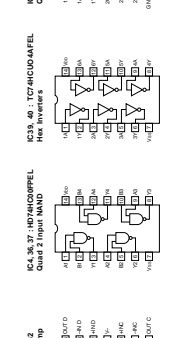
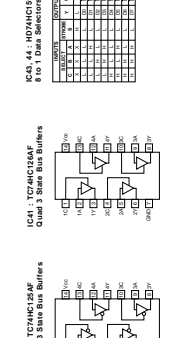
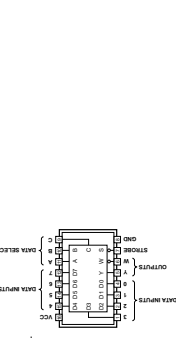
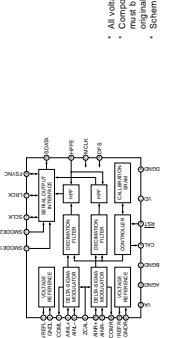

All voltages are measured with a 10MΩ VDC electric voltmeter.
 Components having special characteristics are marked with a triangle (Δ) and must be replaced with parts having specifications equal to those marked.
 Schematic diagram is subject to change without notice.

SCHEMATIC DIAGRAM (FUNCTION)

IC2-3 : TC827AN013 Analog Function Switch

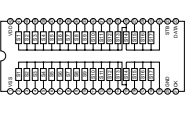

IC11 : C707611 Matrix Japanese 11

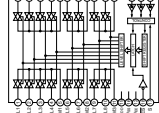

IC21 : LC78612 Analog Function Switch

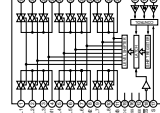

IC16-20 : CS3104ES Stereo Digital Volume Control

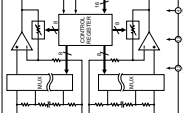

IC9 : LC75951 Stereo Surround Volume

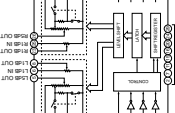

REAR SELECTOR	FRONT SELECTOR	REAR	FRONT	REAR	FRONT	REAR	FRONT	REAR	FRONT	REAR	FRONT	REAR	FRONT	REAR	FRONT	REAR	FRONT	REAR	FRONT
1	1	X	X	X	X	X	X	X	X	X	X	X	X	X	X	X	X	X	X
2	2	X	X	X	X	X	X	X	X	X	X	X	X	X	X	X	X	X	X
3	3	X	X	X	X	X	X	X	X	X	X	X	X	X	X	X	X	X	X
4	4	X	X	X	X	X	X	X	X	X	X	X	X	X	X	X	X	X	X
5	5	X	X	X	X	X	X	X	X	X	X	X	X	X	X	X	X	X	X
6	6	X	X	X	X	X	X	X	X	X	X	X	X	X	X	X	X	X	X
7	7	X	X	X	X	X	X	X	X	X	X	X	X	X	X	X	X	X	X
8	8	X	X	X	X	X	X	X	X	X	X	X	X	X	X	X	X	X	X
9	9	X	X	X	X	X	X	X	X	X	X	X	X	X	X	X	X	X	X
10	10	X	X	X	X	X	X	X	X	X	X	X	X	X	X	X	X	X	X
11	11	X	X	X	X	X	X	X	X	X	X	X	X	X	X	X	X	X	X
12	12	X	X	X	X	X	X	X	X	X	X	X	X	X	X	X	X	X	X
13	13	X	X	X	X	X	X	X	X	X	X	X	X	X	X	X	X	X	X
14	14	X	X	X	X	X	X	X	X	X	X	X	X	X	X	X	X	X	X
15	15	X	X	X	X	X	X	X	X	X	X	X	X	X	X	X	X	X	X
16	16	X	X	X	X	X	X	X	X	X	X	X	X	X	X	X	X	X	X
17	17	X	X	X	X	X	X	X	X	X	X	X	X	X	X	X	X	X	X
18	18	X	X	X	X	X	X	X	X	X	X	X	X	X	X	X	X	X	X
19	19	X	X	X	X	X	X	X	X	X	X	X	X	X	X	X	X	X	X
20	20	X	X	X	X	X	X	X	X	X	X	X	X	X	X	X	X	X	X

Interconnect Part No. Manufacturer Stamp

Part No.	Manufacturer Stamp
1	
2	
3	
4	
5	
6	
7	
8	
9	
10	
11	
12	
13	
14	
15	
16	
17	
18	
19	
20	

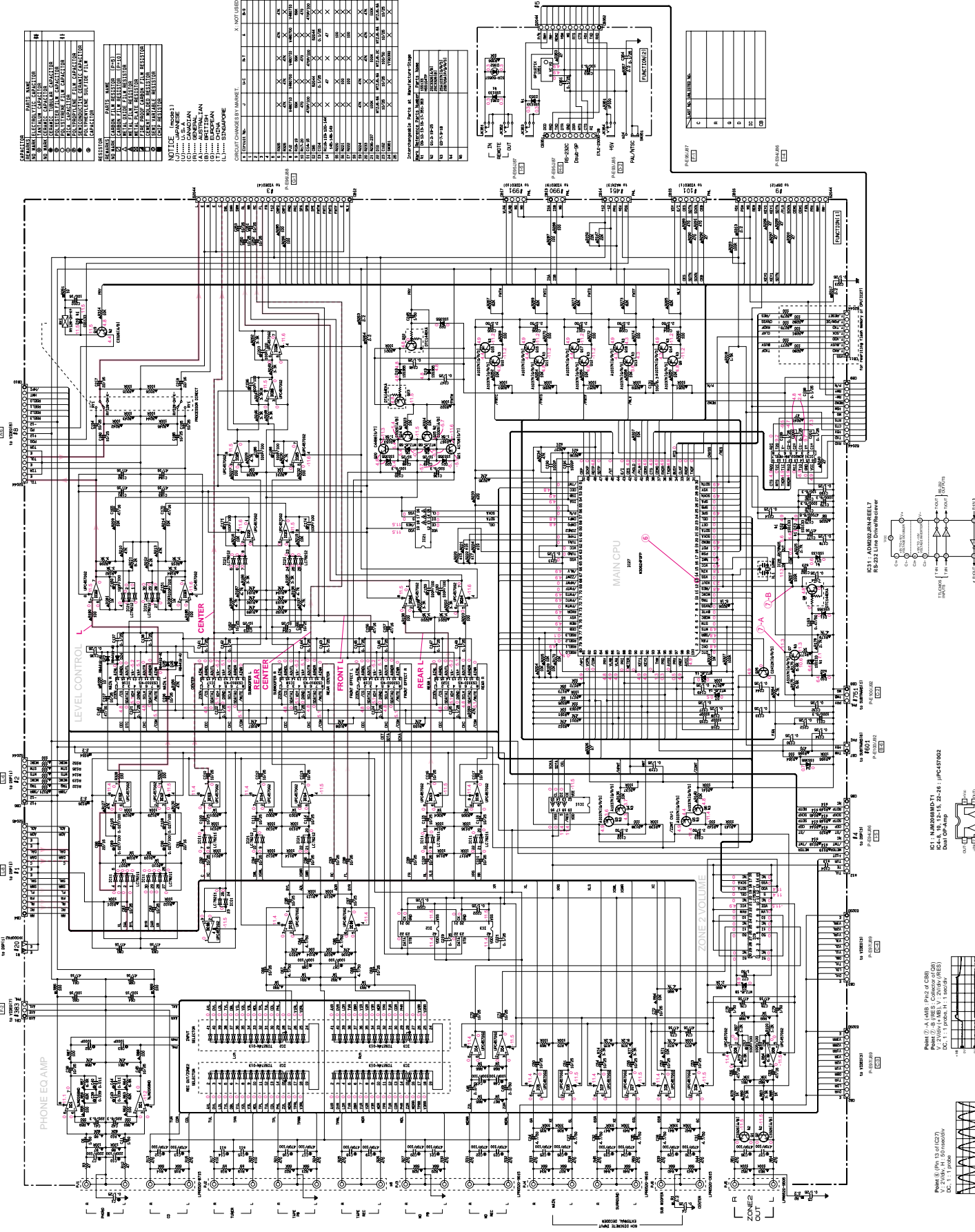

IC11 : AM9020INREEL7 RE-232 Line DriveReceiver

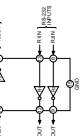

IC1 : N4908ARD-T1 Data Out Amp

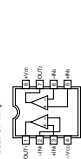

Point (A) : 10V, 100Hz AC (100mV)

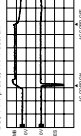

Point (B) : 10V, 100Hz AC (100mV)

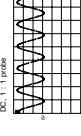

- All voltages are measured with a 10MΩ DC electric voltmeter.
- Components having special characteristics are marked with a triangle (Δ) and must be replaced with parts having specifications equal to those marked.
- Schematic diagram is subject to change without notice.

SCHEMATIC DIAGRAM (MAIN)

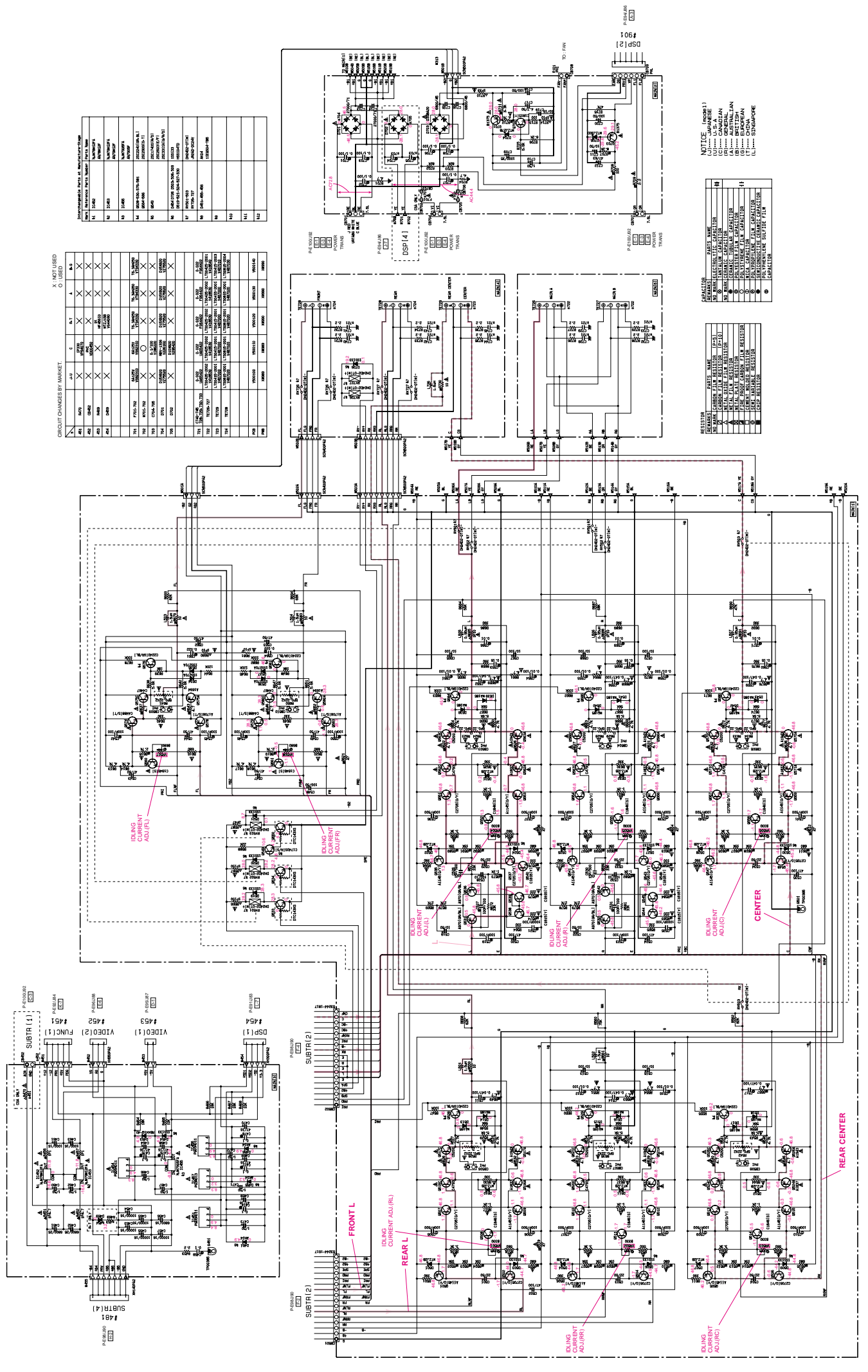

CIRCUIT CHANGES BY MARKET

	A	B	C	D	E	F	G	H	I	J	K	L	M	N
41	✓	✓	✓	✓	✓	✓	✓	✓	✓	✓	✓	✓	✓	✓
42	✓	✓	✓	✓	✓	✓	✓	✓	✓	✓	✓	✓	✓	✓
43	✓	✓	✓	✓	✓	✓	✓	✓	✓	✓	✓	✓	✓	✓
44	✓	✓	✓	✓	✓	✓	✓	✓	✓	✓	✓	✓	✓	✓
45	✓	✓	✓	✓	✓	✓	✓	✓	✓	✓	✓	✓	✓	✓
46	✓	✓	✓	✓	✓	✓	✓	✓	✓	✓	✓	✓	✓	✓
47	✓	✓	✓	✓	✓	✓	✓	✓	✓	✓	✓	✓	✓	✓
48	✓	✓	✓	✓	✓	✓	✓	✓	✓	✓	✓	✓	✓	✓
49	✓	✓	✓	✓	✓	✓	✓	✓	✓	✓	✓	✓	✓	✓
50	✓	✓	✓	✓	✓	✓	✓	✓	✓	✓	✓	✓	✓	✓
51	✓	✓	✓	✓	✓	✓	✓	✓	✓	✓	✓	✓	✓	✓
52	✓	✓	✓	✓	✓	✓	✓	✓	✓	✓	✓	✓	✓	✓
53	✓	✓	✓	✓	✓	✓	✓	✓	✓	✓	✓	✓	✓	✓
54	✓	✓	✓	✓	✓	✓	✓	✓	✓	✓	✓	✓	✓	✓
55	✓	✓	✓	✓	✓	✓	✓	✓	✓	✓	✓	✓	✓	✓
56	✓	✓	✓	✓	✓	✓	✓	✓	✓	✓	✓	✓	✓	✓
57	✓	✓	✓	✓	✓	✓	✓	✓	✓	✓	✓	✓	✓	✓
58	✓	✓	✓	✓	✓	✓	✓	✓	✓	✓	✓	✓	✓	✓
59	✓	✓	✓	✓	✓	✓	✓	✓	✓	✓	✓	✓	✓	✓
60	✓	✓	✓	✓	✓	✓	✓	✓	✓	✓	✓	✓	✓	✓
61	✓	✓	✓	✓	✓	✓	✓	✓	✓	✓	✓	✓	✓	✓
62	✓	✓	✓	✓	✓	✓	✓	✓	✓	✓	✓	✓	✓	✓
63	✓	✓	✓	✓	✓	✓	✓	✓	✓	✓	✓	✓	✓	✓
64	✓	✓	✓	✓	✓	✓	✓	✓	✓	✓	✓	✓	✓	✓
65	✓	✓	✓	✓	✓	✓	✓	✓	✓	✓	✓	✓	✓	✓
66	✓	✓	✓	✓	✓	✓	✓	✓	✓	✓	✓	✓	✓	✓
67	✓	✓	✓	✓	✓	✓	✓	✓	✓	✓	✓	✓	✓	✓
68	✓	✓	✓	✓	✓	✓	✓	✓	✓	✓	✓	✓	✓	✓
69	✓	✓	✓	✓	✓	✓	✓	✓	✓	✓	✓	✓	✓	✓
70	✓	✓	✓	✓	✓	✓	✓	✓	✓	✓	✓	✓	✓	✓
71	✓	✓	✓	✓	✓	✓	✓	✓	✓	✓	✓	✓	✓	✓
72	✓	✓	✓	✓	✓	✓	✓	✓	✓	✓	✓	✓	✓	✓
73	✓	✓	✓	✓	✓	✓	✓	✓	✓	✓	✓	✓	✓	✓
74	✓	✓	✓	✓	✓	✓	✓	✓	✓	✓	✓	✓	✓	✓
75	✓	✓	✓	✓	✓	✓	✓	✓	✓	✓	✓	✓	✓	✓
76	✓	✓	✓	✓	✓	✓	✓	✓	✓	✓	✓	✓	✓	✓
77	✓	✓	✓	✓	✓	✓	✓	✓	✓	✓	✓	✓	✓	✓
78	✓	✓	✓	✓	✓	✓	✓	✓	✓	✓	✓	✓	✓	✓
79	✓	✓	✓	✓	✓	✓	✓	✓	✓	✓	✓	✓	✓	✓
80	✓	✓	✓	✓	✓	✓	✓	✓	✓	✓	✓	✓	✓	✓
81	✓	✓	✓	✓	✓	✓	✓	✓	✓	✓	✓	✓	✓	✓
82	✓	✓	✓	✓	✓	✓	✓	✓	✓	✓	✓	✓	✓	✓
83	✓	✓	✓	✓	✓	✓	✓	✓	✓	✓	✓	✓	✓	✓
84	✓	✓	✓	✓	✓	✓	✓	✓	✓	✓	✓	✓	✓	✓
85	✓	✓	✓	✓	✓	✓	✓	✓	✓	✓	✓	✓	✓	✓
86	✓	✓	✓	✓	✓	✓	✓	✓	✓	✓	✓	✓	✓	✓
87	✓	✓	✓	✓	✓	✓	✓	✓	✓	✓	✓	✓	✓	✓
88	✓	✓	✓	✓	✓	✓	✓	✓	✓	✓	✓	✓	✓	✓
89	✓	✓	✓	✓	✓	✓	✓	✓	✓	✓	✓	✓	✓	✓
90	✓	✓	✓	✓	✓	✓	✓	✓	✓	✓	✓	✓	✓	✓
91	✓	✓	✓	✓	✓	✓	✓	✓	✓	✓	✓	✓	✓	✓
92	✓	✓	✓	✓	✓	✓	✓	✓	✓	✓	✓	✓	✓	✓
93	✓	✓	✓	✓	✓	✓	✓	✓	✓	✓	✓	✓	✓	✓
94	✓	✓	✓	✓	✓	✓	✓	✓	✓	✓	✓	✓	✓	✓
95	✓	✓	✓	✓	✓	✓	✓	✓	✓	✓	✓	✓	✓	✓
96	✓	✓	✓	✓	✓	✓	✓	✓	✓	✓	✓	✓	✓	✓
97	✓	✓	✓	✓	✓	✓	✓	✓	✓	✓	✓	✓	✓	✓
98	✓	✓	✓	✓	✓	✓	✓	✓	✓	✓	✓	✓	✓	✓
99	✓	✓	✓	✓	✓	✓	✓	✓	✓	✓	✓	✓	✓	✓
100	✓	✓	✓	✓	✓	✓	✓	✓	✓	✓	✓	✓	✓	✓

RESISTOR

MARKING	VALUE	TOLERANCE	TEMP. COEFF.
100	100Ω	±5%	±50ppm/°C
1000	1kΩ	±5%	±50ppm/°C
10000	10kΩ	±5%	±50ppm/°C
100000	100kΩ	±5%	±50ppm/°C
1000000	1MΩ	±5%	±50ppm/°C
10000000	10MΩ	±5%	±50ppm/°C
100000000	100MΩ	±5%	±50ppm/°C
1000000000	1GΩ	±5%	±50ppm/°C

CAPACITOR

MARKING	VALUE	TOLERANCE	TEMP. COEFF.
100	100pF	±5%	±50ppm/°C
1000	1nF	±5%	±50ppm/°C
10000	10nF	±5%	±50ppm/°C
100000	100nF	±5%	±50ppm/°C
1000000	1μF	±5%	±50ppm/°C
10000000	10μF	±5%	±50ppm/°C
100000000	100μF	±5%	±50ppm/°C
1000000000	1mF	±5%	±50ppm/°C

NOTICE (except 1)

- U..... JAPANESE
- C..... CANADIAN
- I..... ITALIAN
- IA..... AUSTRALIAN
- IB..... BRITISH
- IC..... SWISS
- LD..... SINGAPORE

All voltage are measured with a 1000V DC electric volt meter.
 Components having special characteristics are marked J, and must be replaced with parts having specifications equal to those.
 Schematic diagram is subject to change without notice.

SCHEMATIC DIAGRAM (DSP(2))

IC901_902 : M6504MBFP-200C
FL Display Driver

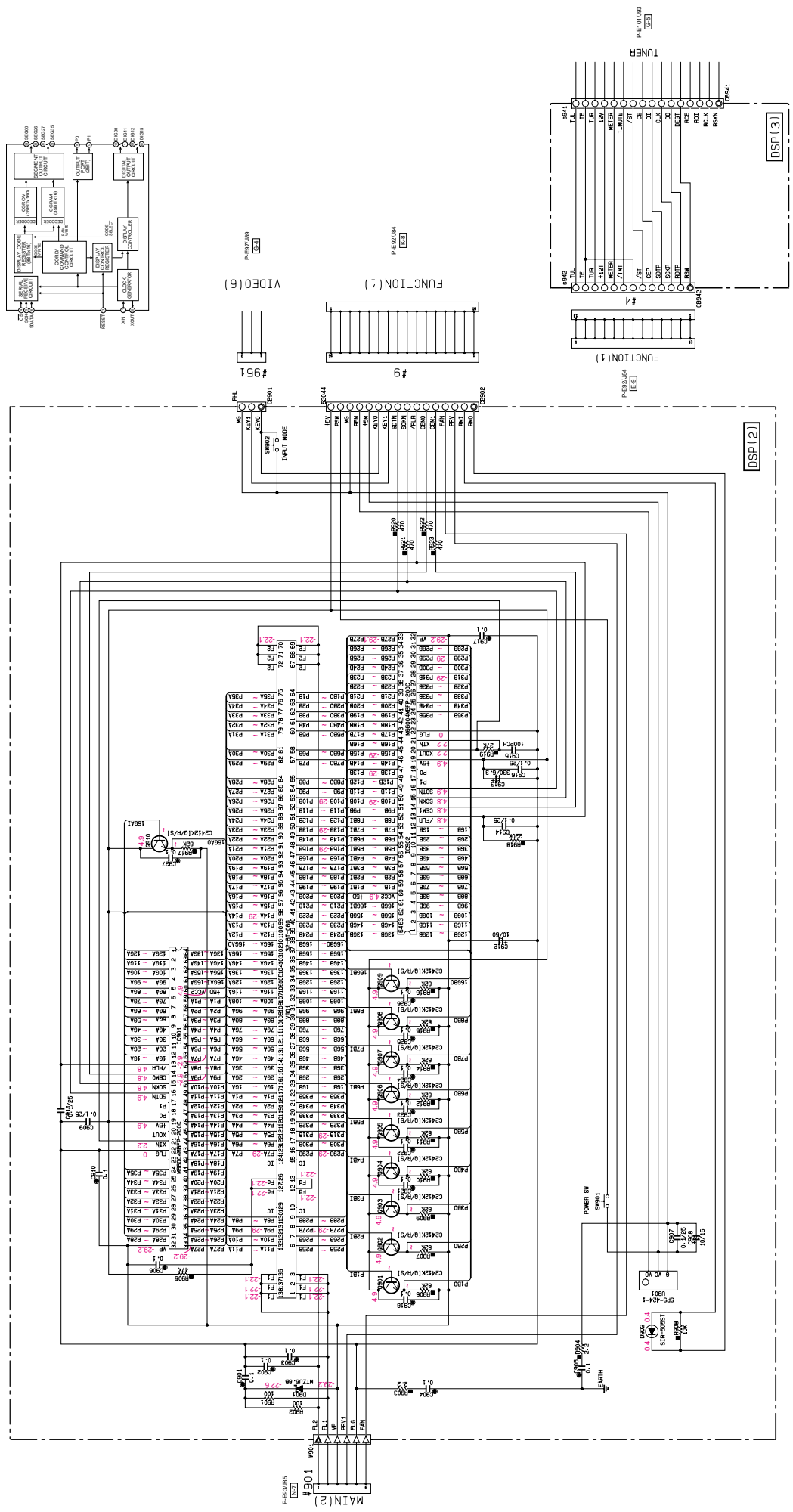

RESISTOR

REMARKS	PARTS NAME
NO MARK	CARBON FILM RESISTOR (P-5)
①	CARBON FILM RESISTOR (P-10)
②	METAL FILM RESISTOR
③	METAL PLATE RESISTOR
④	FIRE PROOF CARBON FILM RESISTOR
⑤	CEMENT MOLDED RESISTOR
⑥	CHIP RESISTOR

CAPACITOR

REMARKS	PARTS NAME
NO MARK	ELECTROLYTIC CAPACITOR
①	TANTALUM CAPACITOR
②	CERAMIC TUBULAR CAPACITOR
③	POLYESTER FILM CAPACITOR
④	MICA CAPACITOR
⑤	POLYPROPYLENE FILM CAPACITOR
⑥	SEMICONDUCTIVE CERAMIC CAPACITOR
⑦	POLYPHENYLENE SULFIDE FILM CAPACITOR

NOTICE (Cont'd.)
 (U)..... JAPAN
 (U)..... U.S.A.
 (C)..... CANADIAN
 (R)..... GENERAL
 (S)..... BRITISH
 (S)..... EUROPEAN
 (L)..... CHINA
 (T)..... SINGAPORE

CIRCUIT CHANGES BY MARKET

S	Parts Number	J-A-B-C-D-E	U-A	MARK
941	CP84	X		TO POWER TRANSFORMER
942	CP84	X		TO MAIN (2)
943	CP84	X		TO MAIN (2)
944	CP84	X		TO MAIN (2)

Interchangeable Parts at Manufacture-Stage
 Mark Reference Parts Number Parts Name

* All voltage are measured with a 10MΩ/DC electric volt meter.
 * Components having special characteristics are marked Δ, and must be replaced with parts having specifications equal to those originally installed.
 * Schematic diagram is subject to change without notice.

SCHEMATIC DIAGRAM (VIDEO)

A B C D E F G H I J K

Part No.	J	U.C.	B.T.	A	B	C
1	U1	LA7840	LA7840 (P)	LA7840 (P)	LA7840 (P)	LA7840 (P)
2	U2	LA7840	LA7840 (P)	LA7840 (P)	LA7840 (P)	LA7840 (P)
3	U3	LA7840	LA7840 (P)	LA7840 (P)	LA7840 (P)	LA7840 (P)
4	U4	LA7840	LA7840 (P)	LA7840 (P)	LA7840 (P)	LA7840 (P)
5	U5	LA7840	LA7840 (P)	LA7840 (P)	LA7840 (P)	LA7840 (P)
6	U6	LA7840	LA7840 (P)	LA7840 (P)	LA7840 (P)	LA7840 (P)
7	U7	LA7840	LA7840 (P)	LA7840 (P)	LA7840 (P)	LA7840 (P)
8	U8	LA7840	LA7840 (P)	LA7840 (P)	LA7840 (P)	LA7840 (P)
9	U9	LA7840	LA7840 (P)	LA7840 (P)	LA7840 (P)	LA7840 (P)
10	U10	LA7840	LA7840 (P)	LA7840 (P)	LA7840 (P)	LA7840 (P)

CIRCUIT CHANGES BY MARKET.

NOTICE (page 1)
 (U)..... U.S.A.
 (J)..... JAPAN
 (R)..... GENERAL
 (A)..... AUSTRALIAN
 (E)..... EUROPEAN
 (T)..... CHINA
 (L)..... SINGAPORE

REMARKS	MARK	CAPACITOR
1. CAPACITANCE	LA7840 (P)	LA7840 (P)
2. TOLERANCE	LA7840 (P)	LA7840 (P)
3. MATERIAL	LA7840 (P)	LA7840 (P)
4. TYPE	LA7840 (P)	LA7840 (P)
5. SIZE	LA7840 (P)	LA7840 (P)
6. SPECIFICATION	LA7840 (P)	LA7840 (P)
7. MANUFACTURER	LA7840 (P)	LA7840 (P)
8. PART NUMBER	LA7840 (P)	LA7840 (P)
9. ORDERING INFORMATION	LA7840 (P)	LA7840 (P)
10. OTHER INFORMATION	LA7840 (P)	LA7840 (P)

REMARKS	MARK	RESISTOR
1. RESISTANCE	LA7840 (P)	LA7840 (P)
2. TOLERANCE	LA7840 (P)	LA7840 (P)
3. MATERIAL	LA7840 (P)	LA7840 (P)
4. TYPE	LA7840 (P)	LA7840 (P)
5. SIZE	LA7840 (P)	LA7840 (P)
6. SPECIFICATION	LA7840 (P)	LA7840 (P)
7. MANUFACTURER	LA7840 (P)	LA7840 (P)
8. PART NUMBER	LA7840 (P)	LA7840 (P)
9. ORDERING INFORMATION	LA7840 (P)	LA7840 (P)
10. OTHER INFORMATION	LA7840 (P)	LA7840 (P)

Mark Reference Number	Part Name
U1	LA7840 (P)
U2	LA7840 (P)
U3	LA7840 (P)
U4	LA7840 (P)
U5	LA7840 (P)
U6	LA7840 (P)
U7	LA7840 (P)
U8	LA7840 (P)
U9	LA7840 (P)
U10	LA7840 (P)

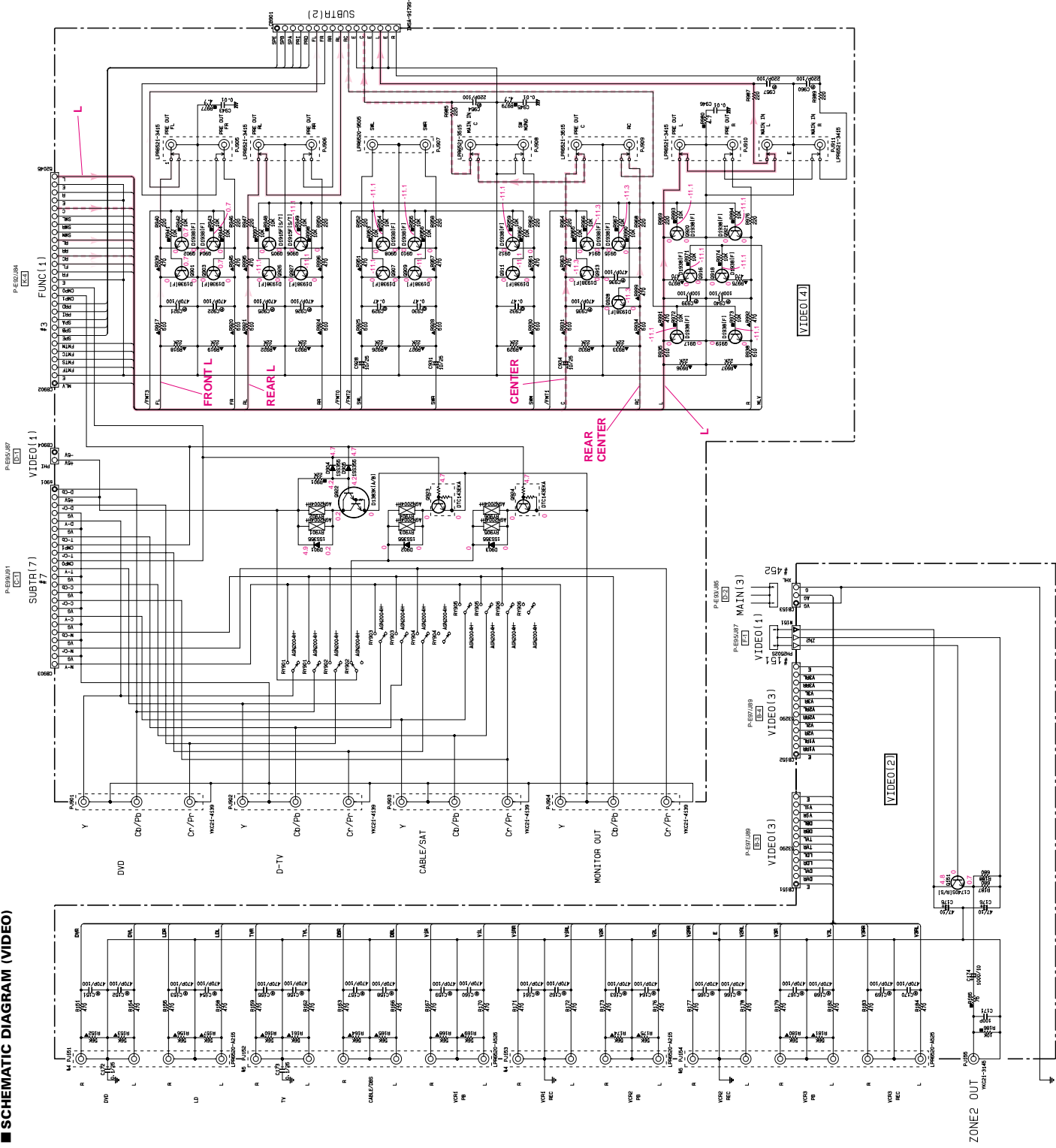

All voltages are measured with a 10MΩ/V DC electric voltmeter.
 Components having special characteristics are marked Δ and must be replaced with parts having specifications equal to those originally installed.
 Schematic diagram is subject to change without notice.

■ SCHEMATIC DIAGRAM (VIDEO)

CIRCUIT CHANGES BY MARKET. X: NOT USED.

Part No.	J	K	L	M	N	O
1	X					
2		X				
3			X			
4				X		
5					X	
6						X
7						

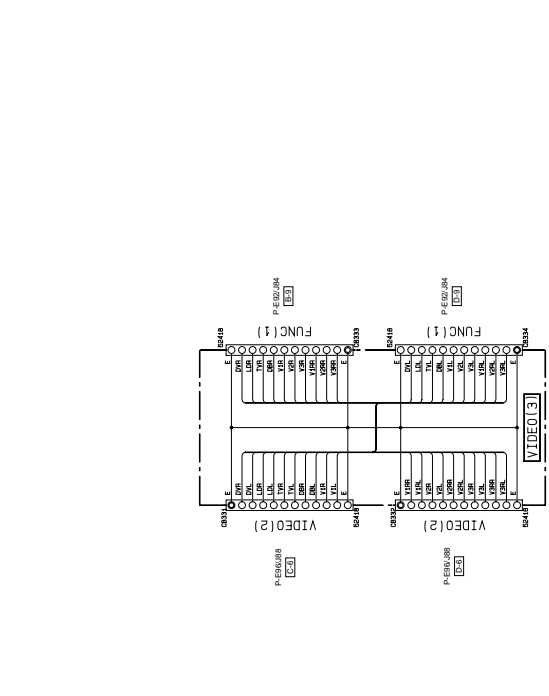
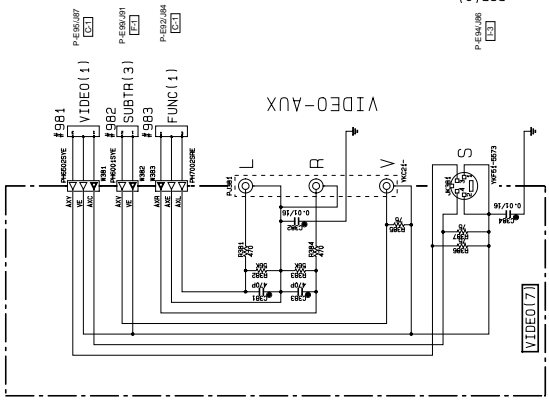

CIRCUIT CHANGES BY MARKET. X: NOT USED.

Part No.	J	K	L	M	N	O
1	X					
2		X				
3			X			
4				X		
5					X	
6						X
7						

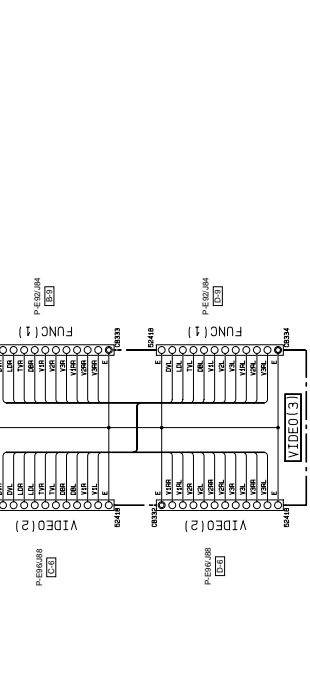
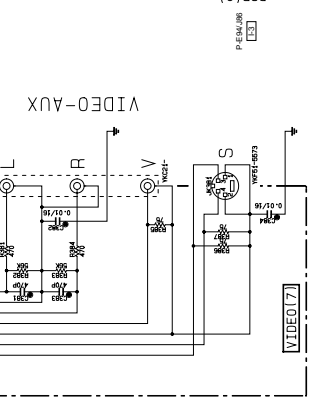
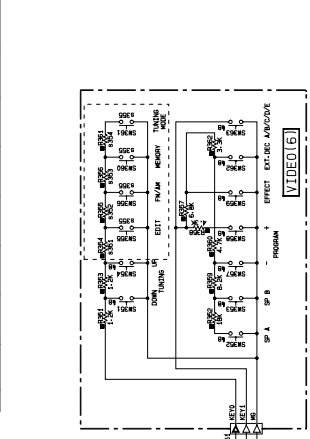

CIRCUIT CHANGES BY MARKET. X: NOT USED.

Part No.	J	K	L	M	N	O
1	X					
2		X				
3			X			
4				X		
5					X	
6						X
7						



RESISTOR

REMARKS	PARTS NAME
NO MARK	CARBON FILM RESISTOR (P-4)
△	METAL OXIDE FILM RESISTOR (P-10)
▲	METAL FILM RESISTOR
●	FIBRE PROOF CARBON FILM RESISTOR
◎	SEWEN RINGED RESISTOR
⊙	CHIP RESISTOR

Interchangeable Parts at Manufacturer's Stage

Name	Reference Parts Number	Part Name
N1	D1C13-14	D1C13&14
N2	56	D1C13&14
N3	D1C13-4,6,7-13	D1C13
N4	FUJIB-103	LEAD-2049
N5	FUJIB154	LEAD-2049
N6		
N7		
N8	SMD1-264-307-309	FUJIB1
N9	303-303	303
N10		
N11		
N12		

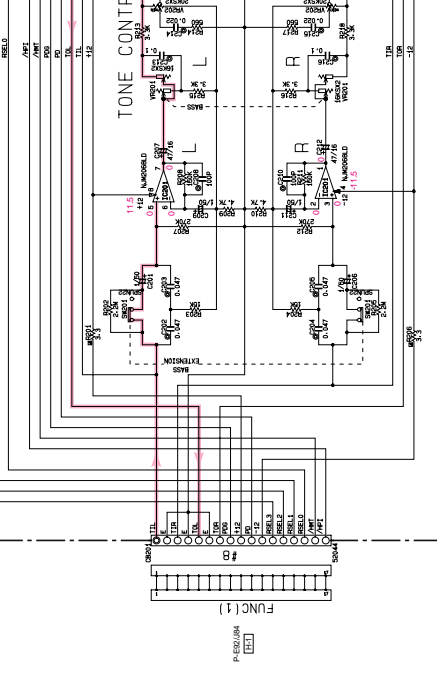
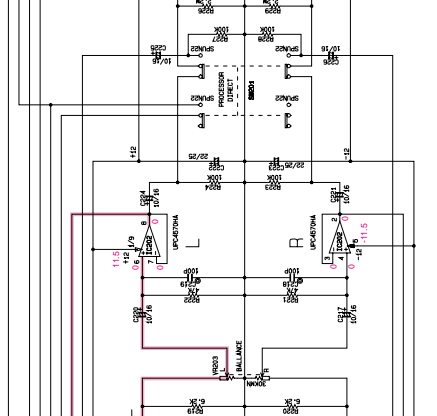
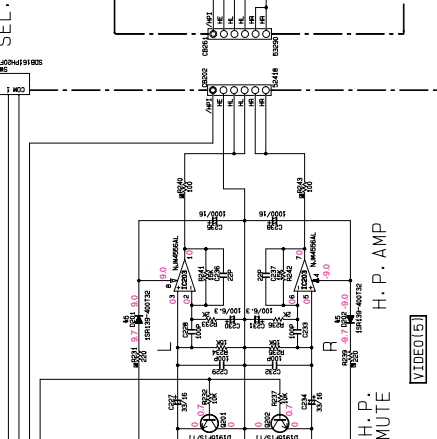
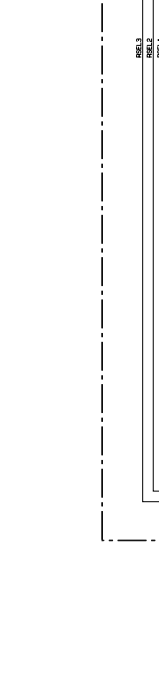

REC OUT SELECTOR

REC OUT SELECTOR	VIDEO	VHS	VCR	TV	LD	SOURCE	PROG	NO	TAPE	TAPE	CD	FM/NO
RESEL0	0	1	0	1	1	0	0	0	1	0	0	0
RESEL1	0	0	1	1	1	0	0	0	0	0	0	1
RESEL2	1	1	1	1	1	1	0	0	0	0	0	0

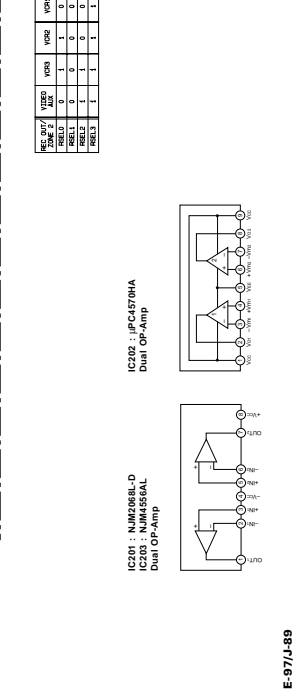
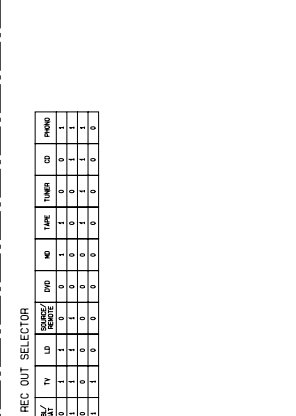

- All voltage are measured with a 10MΩ/V DC electric volt meter.
- Components having special characteristics are marked △ and must be replaced with parts having specifications equal to those originally installed.
- Schematic diagram is subject to change without notice.

SCHEMATIC DIAGRAM (SUB TRANS)

P. 6/24/88

P. 6/24/88

P. 6/24/88

P. 6/24/88

P. 6/24/88

P. 6/24/88

P. 6/24/88

P. 6/24/88

P. 6/24/88

P. 6/24/88

P. 6/24/88

P. 6/24/88

P. 6/24/88

P. 6/24/88

P. 6/24/88

P. 6/24/88

P. 6/24/88

P. 6/24/88

P. 6/24/88

P. 6/24/88

P. 6/24/88

P. 6/24/88

P. 6/24/88

P. 6/24/88

P. 6/24/88

P. 6/24/88

P. 6/24/88

P. 6/24/88

Reference	J	U	C	R	X	S	G
901 (BMTN7)							

Interchangeable Parts at Manufacturer's Stage

Part No.	Reference Part Number	Part Name
13		
14		
15		
16		
17		
18		
19		
20		
21	DS1-100-104	RESISTOR
22		
23		

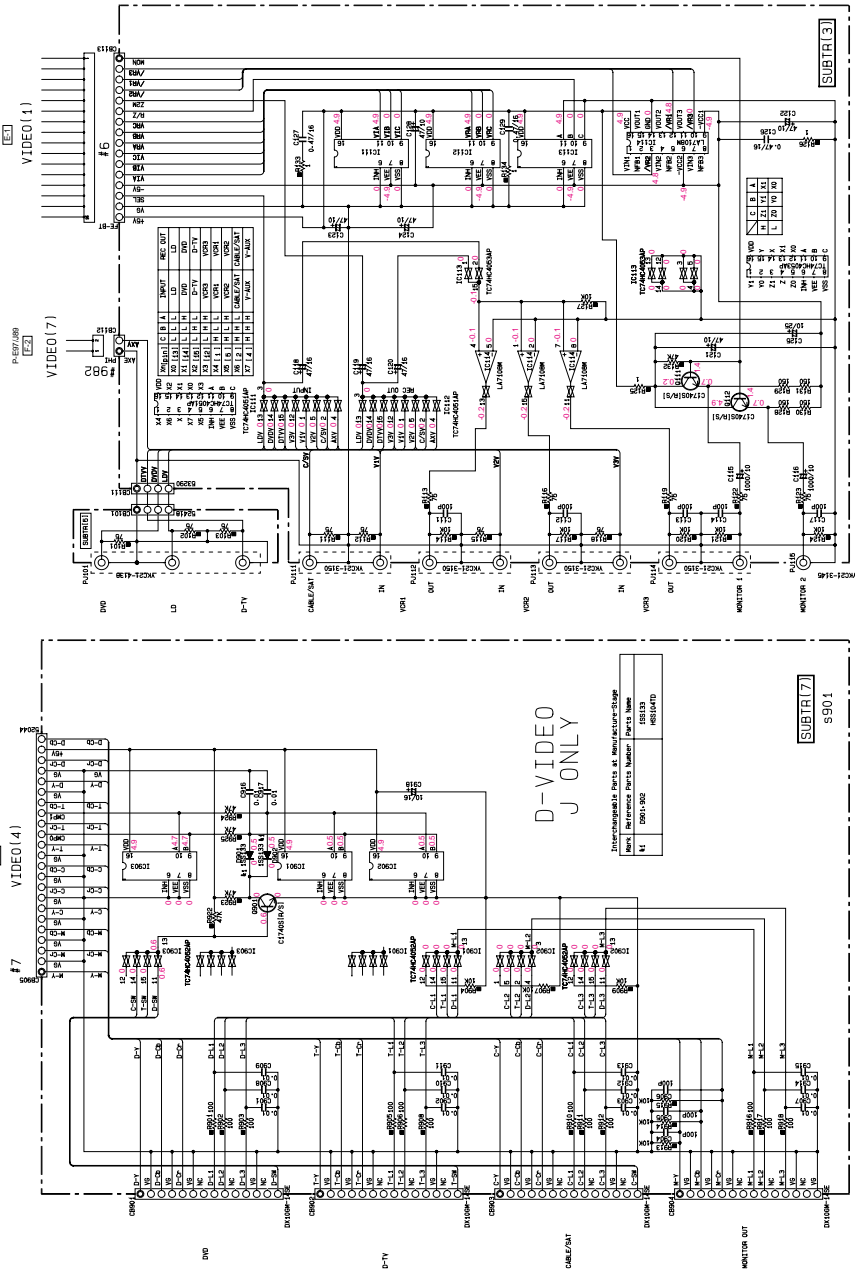

RESISTOR	PARTS NAME	RESISTOR	PARTS NAME
NO MARK	ELECTRICAL CAPACITOR	NO MARK	CARBON FILM RESISTOR (F=5)
NO MARK	TRIMMABLE CAPACITOR	NO MARK	GERMANY FILM RESISTOR (P=10)
NO MARK	TRIMMABLE CAPACITOR	NO MARK	MEL FILM RESISTOR
NO MARK	TRIMMABLE CAPACITOR	NO MARK	POLYESTER FILM RESISTOR
NO MARK	TRIMMABLE CAPACITOR	NO MARK	POLYESTER FILM RESISTOR
NO MARK	TRIMMABLE CAPACITOR	NO MARK	CEMENT WOUND RESISTOR
NO MARK	TRIMMABLE CAPACITOR	NO MARK	SPIN WOUND RESISTOR
NO MARK	TRIMMABLE CAPACITOR	NO MARK	TOLE RESISTOR
NO MARK	TRIMMABLE CAPACITOR	NO MARK	POLYMER SULFIDE FILM

RESISTOR	PARTS NAME	RESISTOR	PARTS NAME
NO MARK	ELECTRICAL CAPACITOR	NO MARK	CARBON FILM RESISTOR (F=5)
NO MARK	TRIMMABLE CAPACITOR	NO MARK	GERMANY FILM RESISTOR (P=10)
NO MARK	TRIMMABLE CAPACITOR	NO MARK	MEL FILM RESISTOR
NO MARK	TRIMMABLE CAPACITOR	NO MARK	POLYESTER FILM RESISTOR
NO MARK	TRIMMABLE CAPACITOR	NO MARK	POLYESTER FILM RESISTOR
NO MARK	TRIMMABLE CAPACITOR	NO MARK	CEMENT WOUND RESISTOR
NO MARK	TRIMMABLE CAPACITOR	NO MARK	SPIN WOUND RESISTOR
NO MARK	TRIMMABLE CAPACITOR	NO MARK	TOLE RESISTOR
NO MARK	TRIMMABLE CAPACITOR	NO MARK	POLYMER SULFIDE FILM

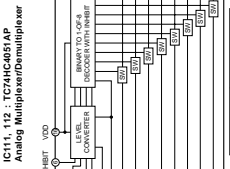
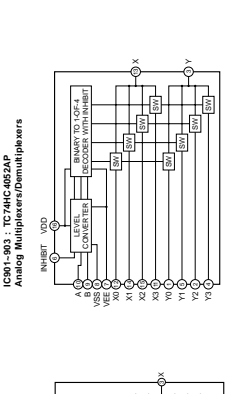
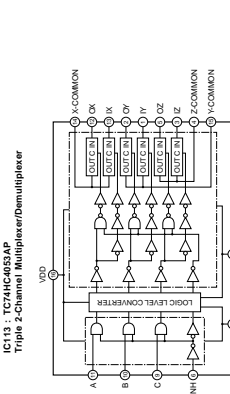
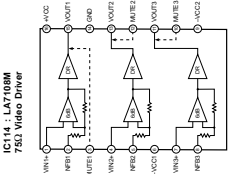

INPUT STATES	ON CHANNEL (R)
0 0 0 0	0
0 0 0 1	1
0 0 1 0	2
0 0 1 1	3
0 1 0 0	4
0 1 0 1	5
0 1 1 0	6
0 1 1 1	7
1 1 1 1	NONE

CONTROL STATES	NON-COMMON
0 0 0 0	0
0 0 0 1	1
0 0 1 0	2
0 0 1 1	3
0 1 0 0	4
0 1 0 1	5
0 1 1 0	6
0 1 1 1	7
1 1 1 1	NONE

CONTROL STATES	NON-COMMON
0 0 0 0	0
0 0 0 1	1
0 0 1 0	2
0 0 1 1	3
0 1 0 0	4
0 1 0 1	5
0 1 1 0	6
0 1 1 1	7
1 1 1 1	NONE

CONTROL STATES	NON-COMMON
0 0 0 0	0
0 0 0 1	1
0 0 1 0	2
0 0 1 1	3
0 1 0 0	4
0 1 0 1	5
0 1 1 0	6
0 1 1 1	7
1 1 1 1	NONE

CONTROL STATES	NON-COMMON
0 0 0 0	0
0 0 0 1	1
0 0 1 0	2
0 0 1 1	3
0 1 0 0	4
0 1 0 1	5
0 1 1 0	6
0 1 1 1	7
1 1 1 1	NONE

• All voltage are measured with a 10Mohm/V DC electric volt meter.
 • Components having special characteristics are marked Δ and must be replaced with parts having specifications equal to those originally installed.
 • Schematic diagram is subject to change without notice.

SCHEMATIC DIAGRAM (TUNER : RX-V1 only)

REMARKS	PARIS NAME
NO MARK ELECTROLYTIC CAPACITOR	P-F
NO MARK FILM RESISTOR	LD
NO MARK CERAMIC TUBULAR CAPACITOR	LD
NO MARK CERAMIC DISC CAPACITOR	LD
NO MARK METAL OXIDE FILM RESISTOR	LD
NO MARK METAL FILM RESISTOR	LD
NO MARK POLYESTER FILM CAPACITOR	LD
NO MARK POLYPROPYLENE FILM CAPACITOR	LD
NO MARK MICA CAPACITOR	LD
NO MARK CERAMIC MOUNTED RESISTOR	LD
NO MARK SEMI VARIABLE RESISTOR	LD
NO MARK SEMI CONDUCTIVE CERAMIC CAPACITOR	LD

REMARKS	PARIS NAME
NO MARK ELECTROLYTIC CAPACITOR	P-F
NO MARK FILM RESISTOR	LD
NO MARK CERAMIC TUBULAR CAPACITOR	LD
NO MARK CERAMIC DISC CAPACITOR	LD
NO MARK METAL OXIDE FILM RESISTOR	LD
NO MARK METAL FILM RESISTOR	LD
NO MARK POLYESTER FILM CAPACITOR	LD
NO MARK POLYPROPYLENE FILM CAPACITOR	LD
NO MARK MICA CAPACITOR	LD
NO MARK CERAMIC MOUNTED RESISTOR	LD
NO MARK SEMI VARIABLE RESISTOR	LD
NO MARK SEMI CONDUCTIVE CERAMIC CAPACITOR	LD

NOTICE (REF. 1)
 (J)..... JAPANESE
 (U)..... U.S.A
 (C)..... CANADIAN
 (G)..... GERMAN
 (A)..... AUSTRALIAN
 (B)..... BRITISH
 (S)..... SWEDISH
 (T)..... THAI
 (L)..... SINGAPORE

Interchangeable parts at Manufacturer's Shop

Mark	Reference Parts Number	Part Name
1	DL-2	181318
1	DL-2	181318

CIRCUIT CHANGES BY MARKET:

U.C.	U.C.	U.C.	U.C.
100000	100010	100020	100030
1 PK1	100010	100010	100010
2 R48	100010	100010	100010
3 T3	100010	100010	100010
4 L41	100010	100010	100010
5 C49	100010	100010	100010
6 R60	100010	100010	100010
7 C36-37	100010	100010	100010
8 R26-37	100010	100010	100010
9 R41	100010	100010	100010
10 L42	100010	100010	100010
11	100010	100010	100010
12 R65-67-68	100010	100010	100010
13 R60	100010	100010	100010
14 R34	100010	100010	100010

○ : USED
 □ : NOT USED

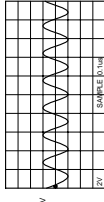
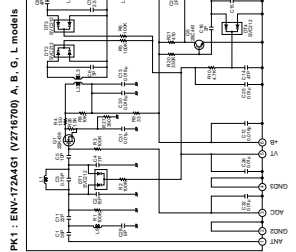
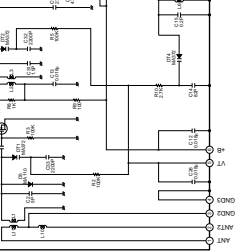
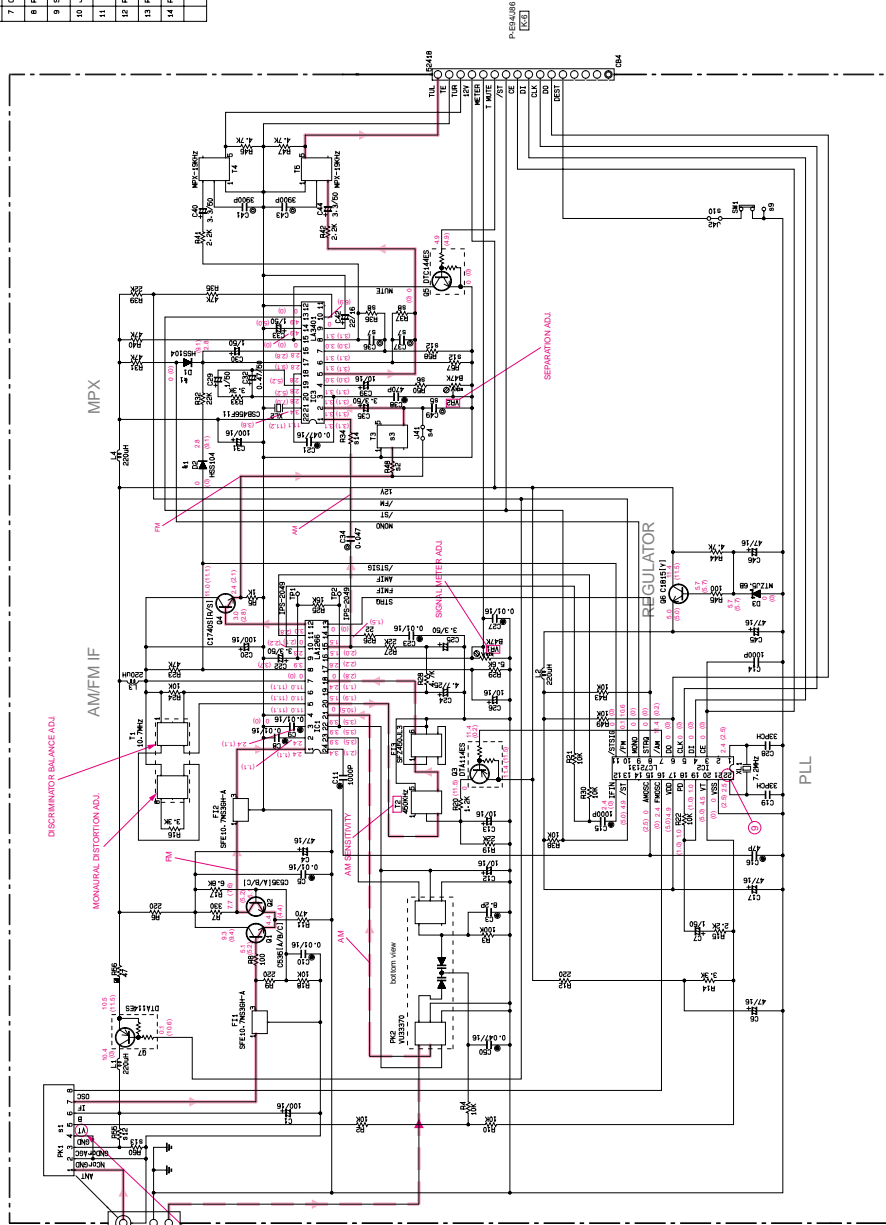

Point ⑨ (Pin22 of IC2)
 V : 2V/div H : 0.1 usec/div
 DC range 1 : 1 probe

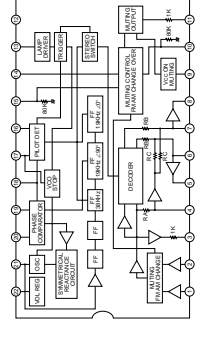
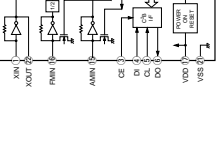
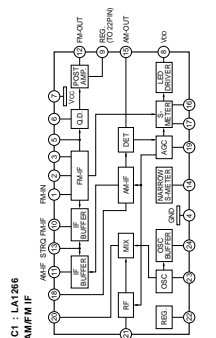

- All voltage are measured with a 10MΩ/V DC electric volt meter.
- Components having special characteristics are marked Δ and must be replaced with parts having specifications equal to those originally installed.
- Schematic diagram is subject to change without notice.

PARTS LIST

■ ELECTRICAL PARTS

■ WARNING

Components having special characteristics are marked \triangle and must be replaced with parts having specifications equal to those originally installed.

- Carbon resistors (1/6W or 1/4W) are not included in the ELECTRICAL PARTS List. For the parts No. of the carbon resistors, refer to last page.
- Chip resistors are listed on page 128.

ABBREVIATIONS IN THIS LIST ARE AS FOLLOWS :

C.A.EL.CHP	: CHIP ALUMI. ELECTROLYTIC CAP	L.EMIT	: LIGHT EMITTING MODULE
C.CE	: CERAMIC CAP	LED.DSPLY	: LED DISPLAY
C.CE.ARRAY	: CERAMIC CAP ARRAY	LED.INFRD	: LED, INFRARED
C.CE.CHP	: CHIP CERAMIC CAP	MODUL.RF	: MODULATOR, RF
C.CE.ML	: MULTILAYER CERAMIC CAP	PHOT.CPL	: PHOTO COUPLER
C.CE.M.CHP	: CHIP MULTILAYER CERAMIC CAP	PHOT.INTR	: PHOTO INTERRUPTER
C.CE.SAFTY	: RECOGNIZED CERAMIC CAP	PHOT.RFLCT	: PHOTO REFLECTOR
C.CE.TUBLR	: CERAMIC TUBULAR CAP	PIN.TEST	: PIN, TEST POINT
C.CE.SMI	: SEMI CONDUCTIVE CERAMIC CAP	PLST.RIVET	: PLASTIC RIVET
C.EL	: ELECTROLYTIC CAP	R.ARRAY	: RESISTOR ARRAY
C.MICA	: MICA CAP	R.CAR	: CARBON RESISTOR
C.ML.FLM	: MULTILAYER FILM CAP	R.CAR.CHP	: CHIP RESISTOR
C.MP	: METALLIZED PAPER CAP	R.CAR.FP	: FLAME PROOF CARBON RESISTOR
C.MYLAR	: MYLAR FILM CAP	R.FUS	: FUSABLE RESISTOR
C.MYLAR.ML	: MULTILAYER MYLAR FILM CAP	R.MTL.CHP	: CHIP METAL FILM RESISTOR
C.PAPER	: PAPER CAPACITOR	R.MTL.FLM	: METAL FILM RESISTOR
C.PLS	: POLYSTYRENE FILM CAP	R.MTL.OXD	: METAL OXIDE FILM RESISTOR
C.POL	: POLYESTER FILM CAP	R.MTL.PLAT	: METAL PLATE RESISTOR
C.POLY	: POLYETHYLENE FILM CAP	RSNR.CE	: CERAMIC RESONATOR
C.PP	: POLYPROPYLENE FILM CAP	RSNR.CRYS	: CRYSTAL RESONATOR
C.TNTL	: TANTALUM CAP	R.TW.CEM	: TWIN CEMENT FIXED RESISTOR
C.TNTL.CHP	: CHIP TANTALUM CAP	R.WW	: WIRE WOUND RESISTOR
C.TRIM	: TRIMMER CAP	SCR.BND.HD	: BIND HEAD B-TITE SCREW
CN	: CONNECTOR	SCR.BW.HD	: BW HEAD TAPPING SCREW
CN.BS.PIN	: CONNECTOR, BASE PIN	SCR.CUP	: CUP TITE SCREW
CN.CANNON	: CONNECTOR, CANNON	SCR.TERM	: SCREW TERMINAL
CN.DIN	: CONNECTOR, DIN	SCR.TR	: SCREW, TRANSISTOR
CN.FLAT	: CONNECTOR, FLAT CABLE	SUPRT.PCB	: SUPPORT, P.C.B.
CN.POST	: CONNECTOR, BASE POST	SURG.PRTCT	: SURGE PROTECTOR
COIL.MX.AM	: COIL, AM MIX	SW.TACT	: TACT SWITCH
COIL.AT.FM	: COIL, FM ANTENNA	SW.LEAF	: LEAF SWITCH
COIL.DT.FM	: COIL, FM DETECT	SW.LEVER	: LEVER SWITCH
COIL.MX.FM	: COIL, FM MIX	SW.MICRO	: MICRO SWITCH
COIL.OUTPT	: OUTPUT COIL	SW.PUSH	: PUSH SWITCH
DIOD.ARRAY	: DIODE ARRAY	SW.RT.ENC	: ROTARY ENCODER
DIODE.BRG	: DIODE BRIDGE	SW.RT.MTR	: ROTARY SWITCH WITH MOTOR
DIODE.CHP	: CHIP DIODE	SW.RT	: ROTARY SWITCH
DIODE.VAR	: VARACTOR DIODE	SW.SLIDE	: SLIDE SWITCH
DIOD.Z.CHP	: CHIP ZENER DIODE	TERM.SP	: SPEAKER TERMINAL
DIODE.ZENR	: ZENER DIODE	TERM.WRAP	: WRAPPING TERMINAL
DSCR.CE	: CERAMIC DISCRIMINATOR	THRMST.CHP	: CHIP THERMISTOR
FER.BEAD	: FERRITE BEADS	TR.CHP	: CHIP TRANSISTOR
FER.CORE	: FERRITE CORE	TR.DGT	: DIGITAL TRANSISTOR
FET.CHP	: CHIP FET	TR.DGT.CHP	: CHIP DIGITAL TRANSISTOR
FL.DSPLY	: FLUORESCENT DISPLAY	TRANS	: TRANSFORMER
FLTR.CE	: CERAMIC FILTER	TRANS.PULS	: PULSE TRANSFORMER
FLTR.COMB	: COMB FILTER MODULE	TRANS.PWR	: POWER TRANSFORMER ASS'y
FLTR.LC.RF	: LC FILTER ,EMI	TUNER.AM	: TUNER PACK, AM
GND.MTL	: GROUND PLATE	TUNER.FM	: TUNER PACK, FM
GND.TERM	: GROUND TERMINAL	TUNER.PK	: FRONT-END TUNER PACK
HOLDER.FUS	: FUSE HOLDER	VR	: ROTARY POTENTIOMETER
IC.PRTCT	: IC PROTECTOR	VR.MTR	: POTENTIOMETER WITH MOTOR
JUMPER.CN	: JUMPER CONNECTOR	VR.SW	: POTENTIOMETER WITH ROTARY SW
JUMPER.TST	: JUMPER, TEST POINT	VR.SLIDE	: SLIDE POTENTIOMETER
L.DTCT	: LIGHT DETECTING MODULE	VR.TRIM	: TRIMMER POTENTIOMETER

Note) Those parts marked with “#” are not included in the P.C.B. ass'y.

P.C.B. MAIN

Schm Ref.	PART NO.	Description		
*	V5001000	P.C.B.	MAIN(U)	
*	V5001100	P.C.B.	MAIN(C)	
*	V5001200	P.C.B.	MAIN(RT)	
*	V5001300	P.C.B.	MAIN(A)	
*	V5001400	P.C.B.	MAIN(BG)	
	CB452	VD004500	CN.BS.PIN	2P(C)
*	CB501	V4807200	CN.BS.PIN	16P
*	CB502	V4807300	CN.BS.PIN	18P
	CB503	VD004500	CN.BS.PIN	2P
	CB504	VD004500	CN.BS.PIN	2P
	CB505	VD004500	CN.BS.PIN	2P
	CB506	VD004500	CN.BS.PIN	2P
	CB507	VD004500	CN.BS.PIN	2P
	CB508	VD004500	CN.BS.PIN	2P
	CB509	VD004500	CN.BS.PIN	2P
	CB510	VD004500	CN.BS.PIN	2P
	CB701	LA002400	TERM.WRAP	3P L-753B
	CB702	VP206500	HOLDER.FUS	EYF-52BC
	CB703	VP206500	HOLDER.FUS	EYF-52BC
	CB704	LA002390	TERM.WRAP	2P
	CB705	VP206500	HOLDER.FUS	EYF-52BC
	CB706	VP206500	HOLDER.FUS	EYF-52BC
	CB707	LA002390	TERM.WRAP	2P
	CB708	VD004500	CN.BS.PIN	2P
	CB709	VB858500	CN.BS.PIN	6P
*	C451	UU149680	C.EL	6800uF 25V
*	C452	UU149680	C.EL	6800uF 25V
*	C453	UU13A100	C.EL	10000uF 16V
*	C454	UU13A100	C.EL	10000uF 16V
*	C455	UU13A100	C.EL	10000uF 16V
*	C456	UU139680	C.EL	6800uF 16V
*	C457	UU13A100	C.EL	10000uF 16V
	C458	VR168300	C.MYLAR.ML	ECQ-V1H104JL3
*	C459	UU137470	C.EL	47uF 16V
*	C460	UU166100	C.EL	1uF 50V
*	C461	UU139100	C.EL	1000uF 16V
*	C462	UU166100	C.EL	1uF 50V
*	C463	UU139100	C.EL	1000uF 16V
*	C464	UU137470	C.EL	47uF 16V
*	C465	UU13A100	C.EL	10000uF 16V
*	C466	UU166100	C.EL	1uF 50V
*	C467	UU166100	C.EL	1uF 50V
*	C468	UU137470	C.EL	47uF 16V
*	C469	UU137470	C.EL	47uF 16V
*	C470	UU137470	C.EL	47uF 16V
*	C471	UU166100	C.EL	1uF 50V
*	C472	UU166100	C.EL	1uF 50V
*	C473	UU166100	C.EL	1uF 50V
	C474	VH053100	C.CE.TUBLR	0.1uF 50V
	C475	VH053100	C.CE.TUBLR	0.1uF 50V
	C476	VH053100	C.CE.TUBLR	0.1uF 50V
	C477	VH053100	C.CE.TUBLR	0.1uF 50V
	C478	VH053100	C.CE.TUBLR	0.1uF 50V

* New Parts

Schm Ref.	PART NO.	Description			
*	C501	UU167220	C.EL	22uF	50V
*	C502	UU197470	C.EL	47uF	100V
*	C503	UU167220	C.EL	22uF	50V
*	C504	UU167220	C.EL	22uF	50V
	C505	FU452100	C.MICA	100pF	500V
	C506	FU452100	C.MICA	100pF	500V
	C507	FU452100	C.MICA	100pF	500V
	C508	FU452100	C.MICA	100pF	500V
	C509	FU452100	C.MICA	100pF	500V
	C510	FU452100	C.MICA	100pF	500V
	C511	VR325300	C.MYLAR	0.047uF	100V
	C512	UT454100	C.PP	0.01uF	100V
*	C513	UU197100	C.EL	10uF	100V
	C514	VR325300	C.MYLAR	0.047uF	100V
*	C515	UU197100	C.EL	10uF	100V
	C516	UT454100	C.PP	0.01uF	100V
	C517	VR325300	C.MYLAR	0.047uF	100V
*	C518	UU167100	C.EL	10uF	50V
	C519	UT452100	C.PP	100pF	100V
*	C520	UU197470	C.EL	47uF	100V
	C521	UT453100	C.PP	1000pF	100V
*	C522	UU167100	C.EL	10uF	50V
	C523	UT452100	C.PP	100pF	100V
*	C524	UU197470	C.EL	47uF	100V
	C525	UT453100	C.PP	1000pF	100V
	C526	FU451150	C.MICA	15pF	500V
	C527	UT452100	C.PP	100pF	100V
*	C528	UU128100	C.EL	100uF	10V
*	C529	UU167220	C.EL	22uF	50V
	C530	FU451150	C.MICA	15pF	500V
	C531	UT452100	C.PP	100pF	100V
*	C532	UU128100	C.EL	100uF	10V
*	C533	UU167220	C.EL	22uF	50V
*	C534	UU167220	C.EL	22uF	50V
*	C535	UU197470	C.EL	47uF	100V
	C536	FU452100	C.MICA	100pF	500V
	C537	FU452100	C.MICA	100pF	500V
	C538	FU452100	C.MICA	100pF	500V
	C539	FU452100	C.MICA	100pF	500V
	C540	FU452100	C.MICA	100pF	500V
	C541	FU452100	C.MICA	100pF	500V
	C542	VR325000	C.MYLAR	100pF	100V
*	C543	UU167470	C.EL	47uF	50V
*	C544	UU167470	C.EL	47uF	50V
	C545	VR325000	C.MYLAR	100pF	100V
	C546	VR325000	C.MYLAR	100pF	100V
*	C547	UU167470	C.EL	47uF	50V
*	C548	UU168100	C.EL	100uF	50V
*	C549	UU167470	C.EL	47uF	50V
	C550	VR325000	C.MYLAR	100pF	100V
	C551	UT454100	C.PP	0.01uF	100V
	C552	VR325300	C.MYLAR	0.047uF	100V
	C553	VE326200	C.MYLAR.ML	0.15uF	50V

* New Parts

P.C.B. MAIN

Schm Ref.	PART NO.	Description
C554	UT454100	C.PP 0.01uF 100V
C555	UT454100	C.PP 0.01uF 100V
C556	VR325300	C.MYLAR 0.047uF 100V
C557	VE326200	C.MYLAR.ML 0.15uF 50V
C558	UT454100	C.PP 0.01uF 100V
C559	VR325300	C.MYLAR 0.047uF 100V
C560	VE326200	C.MYLAR.ML 0.15uF 50V
C561	UA654220	C.MYLAR 0.022uF 50V
* C562	UU167470	C.EL 47uF 50V
* C563	UU167470	C.EL 47uF 50V
C564	UA654220	C.MYLAR 0.022uF 50V
* C565	UU197100	C.EL 10uF 100V
C566	VE324800	C.MYLAR.ML 0.01uF 50V
* C567	UU197100	C.EL 10uF 100V
* C568	UU197100	C.EL 10uF 100V
C569	VE324800	C.MYLAR.ML 0.01uF 50V
* C570	UU197100	C.EL 10uF 100V
C571	VE324800	C.MYLAR.ML 0.01uF 50V
C701	Vi862200	C.POLY 0.1uF 100V
C702	Vi862200	C.POLY 0.1uF 100V
C703	Vi862200	C.POLY 0.1uF 100V
C704	Vi862200	C.POLY 0.1uF 100V(C)
C705	Vi862200	C.POLY 0.1uF 100V(C)
C706	Vi862200	C.POLY 0.1uF 100V
C707	Vi862200	C.POLY 0.1uF 100V
C708	Vi862200	C.POLY 0.1uF 100V
* C709	UU159100	C.EL 1000uF 35V
* C710	UU166100	C.EL 1uF 50V
* C711	UU167100	C.EL 10uF 50V
* C712	UU177470	C.EL 47uF 63V
C713	VZ726000	C.EL 27000uF 71V
C714	VZ726000	C.EL 27000uF 71V
* C715	V5089400	C.EL 6800uF 45V
* C716	V5089400	C.EL 6800uF 45V
* C717	UU166470	C.EL 4.7uF 50V
* C718	UU168100	C.EL 100uF 50V
* C719	UU137100	C.EL 10uF 16V
* C720	UU168100	C.EL 100uF 50V
C728	FG244220	C.CE 0.022uF 50V(RTABG)
C728	UA654220	C.MYLAR 0.022uF 50V(UC)
C729	FG244220	C.CE 0.022uF 50V(RTABG)
C729	UA654220	C.MYLAR 0.022uF 50V(UC)
C732	FG244220	C.CE 0.022uF 50V(RTABG)
C732	UA654220	C.MYLAR 0.022uF 50V(UC)
C733	FG244220	C.CE 0.022uF 50V(RTABG)
C733	UA654220	C.MYLAR 0.022uF 50V(UC)
C740	FG244220	C.CE 0.022uF 50V(RTABG)
C740	UA654220	C.MYLAR 0.022uF 50V(UC)
C741	FG244220	C.CE 0.022uF 50V(RTABG)
C741	UA654220	C.MYLAR 0.022uF 50V(UC)
C742	FG244220	C.CE 0.022uF 50V(RTABG)
C742	UA654220	C.MYLAR 0.022uF 50V(UC)
C743	FG244220	C.CE 0.022uF 50V(RTABG)

* New Parts

Schm Ref.	PART NO.	Description
C743	UA654220	C.MYLAR 0.022uF 50V(UC)
C744	FG244220	C.CE 0.022uF 50V(RTABG)
C744	UA654220	C.MYLAR 0.022uF 50V(UC)
C745	FG244220	C.CE 0.022uF 50V(RTABG)
C745	UA654220	C.MYLAR 0.022uF 50V(UC)
D451	VU391800	DIODE.SHOT AK04 WK
D453	VU647200	DIODE.SHOT RB441Q-40 T-77
D454	iF004600	DIODE 1SS133
D455	VU391800	DIODE.SHOT AK04 WK
D456	VU391800	DIODE.SHOT AK04 WK
D459	VG440800	DIODE.ZENR MTZJ15B 15V(RT)
D501	VG435100	DIODE.ZENR MTZJ2.0B 2.0V
D503	iF004600	DIODE 1SS133
D504	VG435100	DIODE.ZENR MTZJ2.0B 2.0V
D506	iF004600	DIODE 1SS133
D507	VG435100	DIODE.ZENR MTZJ2.0B 2.0V
D509	iF004600	DIODE 1SS133
D510	VG435100	DIODE.ZENR MTZJ2.0B 2.0V
D511	VG435100	DIODE.ZENR MTZJ2.0B 2.0V
D512	VG435100	DIODE.ZENR MTZJ2.0B 2.0V
D513	VC398400	DIODE MA185
D514	VC398400	DIODE MA185
D515	VC398400	DIODE MA185
D516	VC398400	DIODE MA185
D517	VC398400	DIODE MA185
D518	VC398400	DIODE MA185
D519	iF004600	DIODE 1SS133
D520	iF004600	DIODE 1SS133
D521	iF004600	DIODE 1SS133
D522	VG435100	DIODE.ZENR MTZJ2.0B 2.0V
D524	iF004600	DIODE 1SS133
D525	VG435100	DIODE.ZENR MTZJ2.0B 2.0V
D527	iF004600	DIODE 1SS133
D528	VG435100	DIODE.ZENR MTZJ2.0B 2.0V
D530	iF004600	DIODE 1SS133
D531	VG435100	DIODE.ZENR MTZJ2.0B 2.0V
D532	VG435100	DIODE.ZENR MTZJ2.0B 2.0V
D533	VG435100	DIODE.ZENR MTZJ2.0B 2.0V
D534	VN008700	DIODE 1SS270A
D535	VN008700	DIODE 1SS270A
D536	VN008700	DIODE 1SS270A
D537	VN008700	DIODE 1SS270A
D538	VC398400	DIODE MA185
D539	VC398400	DIODE MA185
D540	VC398400	DIODE MA185
D541	VC398400	DIODE MA185
D542	VC398400	DIODE MA185
D543	VC398400	DIODE MA185
△ D701	V2261600	DIODE.BRG RBV1306 13A600V(C)
△ D701	VZ755200	DIODE.BRG D15XB20 15A200V(URTABG)
△ D702	V2954200	DIODE.BRG D10XB20 10A200V(C)
△ D703	VN011300	DIODE.BRG D3SBA20 4A 200V
D704	VG442900	DIODE.ZENR MTZJ27B 27V

* New Parts

P.C.B. MAIN

Schm Ref.	PART NO.	Description
D705	VG443500	DIODE.ZENR MTZJ30D 30V
D726	iF004600	DIODE 1SS133
△ F701	VS823100	FUSE 6.0A 125V(UC)
△* F701	VT943300	FUSE TH 6.30A S(RTABG)
△ F702	VS823100	FUSE 6.0A 125V(UC)
△* F702	VT943300	FUSE TH 6.30A S(RTABG)
G451	VR463400	TERM.GND D3.5 TP00385
G501	VR463400	TERM.GND D3.5 TP00385
HS701	VZ681300	HEAT.SINK PWR
△ IC451	XU814A00	IC PQ05RD11 +5V 1.0A
△ IC452	XJ602A00	IC NJM78M12FA
△ IC453	XD343A00	IC NJM79M12FA
△ IC454	XU814A00	IC PQ05RD11 +5V 1.0A
△ IC455	XK309A00	IC NJM7905FA -5V
△ IC456	XU814A00	IC PQ05RD11 +5V 1.0A
△* IC457	XY045A00	IC PQ3RD13 3.3V 1.0A
L501	GD900470	COIL 1.5uH
L502	GD900470	COIL 1.5uH
L503	GD900470	COIL 1.5uH
L504	GD900470	COIL 1.5uH
L505	VC664100	COIL 0.95uH
L506	VC664100	COIL 0.95uH
L507	VC664100	COIL 0.95uH
L726	VU751000	COIL 1.5uH
Q501	VE198700	TR 2SA1145 O,Y
Q502	VE198800	TR 2SC2705 O,Y
Q503	VE198700	TR 2SA1145 O,Y
Q504	VE198800	TR 2SC2705 O,Y
Q505	VE198700	TR 2SA1145 O,Y
Q506	VE198800	TR 2SC2705 O,Y
Q507	VE198800	TR 2SC2705 O,Y
# Q508	VC398100	TR 2SC1846 S
Q509	VE198700	TR 2SA1145 O,Y
Q510	VE198800	TR 2SC2705 O,Y
# Q511	VC398100	TR 2SC1846 S
Q512	VE198700	TR 2SA1145 O,Y
Q513	VE198800	TR 2SC2705 O,Y
# Q514	VC398100	TR 2SC1846 S
Q515	VE198700	TR 2SA1145 O,Y
△ Q516A	iX632610	TR 2SA1837 O,Y
△ Q516C	iX632620	TR 2SC4793 O,Y
△# Q517	V4863600	TR.PAIR 2SA1943/C5200 O,R
△ Q520A	iX632610	TR 2SA1837 O,Y
△ Q520C	iX632620	TR 2SC4793 O,Y
△# Q521	V4863600	TR.PAIR 2SA1943/C5200 O,R
△ Q524A	iX632610	TR 2SA1837 O,Y
△ Q524C	iX632620	TR 2SC4793 O,Y
△# Q525	V4863600	TR.PAIR 2SA1943/C5200 O,R
Q528	iC224030	TR 2SC2240 GR,BL
Q529	iC224030	TR 2SC2240 GR,BL
Q530	iC224030	TR 2SC2240 GR,BL
Q531	iA097000	TR 2SA970 GR,BL
Q532	iA097000	TR 2SA970 GR,BL

* New Parts

Schm Ref.	PART NO.	Description
Q533	VD488500	TR.DGT DTC143XS
Q534	VD488500	TR.DGT DTC143XS
Q535	VE198700	TR 2SA1145 O,Y
Q536	iA097000	TR 2SA970 GR,BL
Q537	VE198800	TR 2SC2705 O,Y
Q538	iC1815C0	TR 2SC1815 Y
Q539	iC1815C0	TR 2SC1815 Y
Q540	iC1815C0	TR 2SC1815 Y
Q541	VE198700	TR 2SA1145 O,Y
Q542	iA097000	TR 2SA970 GR,BL
Q543	VE198800	TR 2SC2705 O,Y
Q544	iC1815C0	TR 2SC1815 Y
Q545	iC1815C0	TR 2SC1815 Y
Q546	iC1815C0	TR 2SC1815 Y
Q547	VE198700	TR 2SA1145 O,Y
Q548	VE198800	TR 2SC2705 O,Y
Q549	iC174020	TR 2SC1740S R,S
Q550	VD488500	TR.DGT DTC143XS
Q551	VE198800	TR 2SC2705 O,Y
# Q552	VC398100	TR 2SC1846 S
Q553	VE198700	TR 2SA1145 O,Y
Q554	VE198800	TR 2SC2705 O,Y
# Q555	VC398100	TR 2SC1846 S
Q556	VE198700	TR 2SA1145 O,Y
Q557	VE198800	TR 2SC2705 O,Y
# Q558	VC398100	TR 2SC1846 S
Q559	VE198700	TR 2SA1145 O,Y
△# Q560	VC398100	TR 2SC1846 S
△# Q561	VC398100	TR 2SC1846 S
△ Q562A	iX632610	TR 2SA1837 O,Y
△ Q562C	iX632620	TR 2SC4793 O,Y
△# Q563	V4863600	TR.PAIR 2SA1943/C5200 O,R
△# Q566	V4863600	TR.PAIR 2SA1943/C5200 O,R
△ Q567A	iX632610	TR 2SA1837 O,Y
△ Q567C	iX632620	TR 2SC4793 O,Y
△# Q570	V4863600	TR.PAIR 2SA1943/C5200 O,R
△ Q571A	iX632610	TR 2SA1837 O,Y
△ Q571C	iX632620	TR 2SC4793 O,Y
△ Q574	VP872700	TR 2SC4488 S,T
# Q575A	iX615750	TR 2SA1694 O,P,Y
# Q575C	iX615760	TR 2SC4467 O,P,Y
Q576	iC224030	TR 2SC2240 GR,BL
△ Q578	VP872600	TR 2SA1708 S,T
△ Q579	VP872700	TR 2SC4488 S,T
# Q580A	iX615750	TR 2SA1694 O,P,Y
# Q580C	iX615760	TR 2SC4467 O,P,Y
Q581	iC224030	TR 2SC2240 GR,BL
△ Q583	VP872600	TR 2SA1708 S,T
Q584	iC224030	TR 2SC2240 GR,BL
Q585	iC224030	TR 2SC2240 GR,BL
Q586	iC224030	TR 2SC2240 GR,BL
△ Q701	VS548300	TR 2SB1375
Q702	iC1815C0	TR 2SC1815 Y

* New Parts

P.C.B. MAIN

Schm Ref.	PART NO.	Description		
△	Q703	VS548300	TR	2SB1375
△	R451	VP939700	R.MTL.FLM	4.7Ω 1W
△	R452	VP939700	R.MTL.FLM	4.7Ω 1W
△	R456	VP939500	R.MTL.FLM	1Ω 1W
△	R457	VP939500	R.MTL.FLM	1Ω 1W
△	R470	HL315330	R.MTL.OXD	330Ω 1W(C)
	R501	VK188500	R.FUS	390Ω 1/4W
	R502	HV457150	R.CAR.FP	15KΩ 1/4W
	R503	HV457150	R.CAR.FP	15KΩ 1/4W
	R504	HV457150	R.CAR.FP	15KΩ 1/4W
△	R505	HV455680	R.CAR.FP	680Ω 1/4W
	R506	VK188500	R.FUS	390Ω 1/4W
	R507	HV457150	R.CAR.FP	15KΩ 1/4W
	R508	HV457150	R.CAR.FP	15KΩ 1/4W
	R509	HV457150	R.CAR.FP	15KΩ 1/4W
△	R510	HV455680	R.CAR.FP	680Ω 1/4W
	R511	VK188500	R.FUS	390Ω 1/4W
	R512	HV457150	R.CAR.FP	15KΩ 1/4W
	R513	HV457150	R.CAR.FP	15KΩ 1/4W
	R514	HV457150	R.CAR.FP	15KΩ 1/4W
△	R515	HV455680	R.CAR.FP	680Ω 1/4W
△	R516	VK189500	R.FUS	3.3KΩ 1/4W
△	R517	VK189100	R.FUS	1.2KΩ 1/4W
△	R518	VK188700	R.FUS	560Ω 1/4W
△	R519	HV454470	R.CAR.FP	47Ω 1/4W
△	R520	VK189500	R.FUS	3.3KΩ 1/4W
△	R521	VK189100	R.FUS	1.2KΩ 1/4W
△	R522	VK188700	R.FUS	560Ω 1/4W
△	R523	VK189500	R.FUS	3.3KΩ 1/4W
△	R524	VK189100	R.FUS	1.2KΩ 1/4W
△	R525	VK188700	R.FUS	560Ω 1/4W
△	R526	HV453470	R.CAR.FP	4.7Ω 1/4W
△	R528	HZ003780	R.MTL.PLAT	0.22Ω+0.22 5W
△	R530	VK188400	R.FUS	330Ω 1/4W
△	R532	HV453470	R.CAR.FP	4.7Ω 1/4W
△	R533	HV453470	R.CAR.FP	4.7Ω 1/4W
△	R535	HZ003780	R.MTL.PLAT	0.22Ω+0.22 5W
△	R537	VK188400	R.FUS	330Ω 1/4W
△	R539	HV453470	R.CAR.FP	4.7Ω 1/4W
△	R540	HV453470	R.CAR.FP	4.7Ω 1/4W
△	R542	HZ003780	R.MTL.PLAT	0.22Ω+0.22 5W
△	R544	VK188400	R.FUS	330Ω 1/4W
△	R546	HV453470	R.CAR.FP	4.7Ω 1/4W
△	R549	HV453470	R.CAR.FP	4.7Ω 1/4W
△	R551	VE009700	R.FUS	4.7Ω 1/4W
△	R553	HV453470	R.CAR.FP	4.7Ω 1/4W
△	R554	VE009700	R.FUS	4.7Ω 1/4W
△	R557	HV453470	R.CAR.FP	4.7Ω 1/4W
	R559	HV454100	R.CAR.FP	10Ω 1/4W
	R561	HV454100	R.CAR.FP	10Ω 1/4W
△	R566	HL315150	R.MTL.OXD	150Ω 1W
△	R567	HL315150	R.MTL.OXD	150Ω 1W
△	R568	VK188500	R.FUS	390Ω 1/4W

* New Parts

Schm Ref.	PART NO.	Description		
△	R574	HV455220	R.CAR.FP	220Ω 1/4W
△	R575	HV455220	R.CAR.FP	220Ω 1/4W
△	R576	HV455100	R.CAR.FP	100Ω 1/4W
△	R577	VK188500	R.FUS	390Ω 1/4W
△	R583	HV455220	R.CAR.FP	220Ω 1/4W
△	R584	HV455220	R.CAR.FP	220Ω 1/4W
△	R585	HV455100	R.CAR.FP	100Ω 1/4W
△	R586	VK188500	R.FUS	390Ω 1/4W
△	R587	HL324470	R.MTL.OXD	47Ω 2W
	R589	HV457150	R.CAR.FP	15KΩ 1/4W
△	R590	VK189500	R.FUS	3.3KΩ 1/4W
	R591	HV457150	R.CAR.FP	15KΩ 1/4W
	R592	HV457150	R.CAR.FP	15KΩ 1/4W
△	R593	VK189100	R.FUS	1.2KΩ 1/4W
△	R594	VK188700	R.FUS	560Ω 1/4W
△	R595	HV455680	R.CAR.FP	680Ω 1/4W
△	R596	HV454470	R.CAR.FP	47Ω 1/4W
	R597	HV457150	R.CAR.FP	15KΩ 1/4W
△	R598	VK189500	R.FUS	3.3KΩ 1/4W
	R599	HV457150	R.CAR.FP	15KΩ 1/4W
	R600	HV457150	R.CAR.FP	15KΩ 1/4W
△	R601	VK189100	R.FUS	1.2KΩ 1/4W
△	R602	VK188700	R.FUS	560Ω 1/4W
△	R603	HV455680	R.CAR.FP	680Ω 1/4W
△	R604	HV454470	R.CAR.FP	47Ω 1/4W
	R605	HV457150	R.CAR.FP	15KΩ 1/4W
△	R606	VK189500	R.FUS	3.3KΩ 1/4W
	R607	HV457150	R.CAR.FP	15KΩ 1/4W
	R608	HV457150	R.CAR.FP	15KΩ 1/4W
△	R609	VK189100	R.FUS	1.2KΩ 1/4W
△	R610	VK188700	R.FUS	560Ω 1/4W
△	R611	HV455680	R.CAR.FP	680Ω 1/4W
△	R612	HV454470	R.CAR.FP	47Ω 1/4W
△	R615	HV456270	R.CAR.FP	2.7KΩ 1/4W
△	R616	VK188800	R.FUS	680Ω 1/4W
△	R619	HV456270	R.CAR.FP	2.7KΩ 1/4W
△	R620	VK188800	R.FUS	680Ω 1/4W
△	R621	HV454470	R.CAR.FP	47Ω 1/4W
△	R622	HV453470	R.CAR.FP	4.7Ω 1/4W
△*	R623	V4863500	R.WW	0.22Ω 5W
△*	R624	V4863500	R.WW	0.22Ω 5W
△	R625	VK188400	R.FUS	330Ω 1/4W
△	R626	HV453470	R.CAR.FP	4.7Ω 1/4W
△	R627	HV453470	R.CAR.FP	4.7Ω 1/4W
△*	R628	V4863500	R.WW	0.22Ω 5W
△*	R629	V4863500	R.WW	0.22Ω 5W
△	R630	VK188400	R.FUS	330Ω 1/4W
△	R631	HV453470	R.CAR.FP	4.7Ω 1/4W
△	R632	HV453470	R.CAR.FP	4.7Ω 1/4W
△*	R633	V4863500	R.WW	0.22Ω 5W
△*	R634	V4863500	R.WW	0.22Ω 5W
△	R635	VK188400	R.FUS	330Ω 1/4W
△	R636	HV453470	R.CAR.FP	4.7Ω 1/4W

* New Parts

P.C.B. MAIN & VIDEO

Schm Ref.	PART NO.	Description		
△ R637	HV453470	R.CAR.FP	4.7Ω	1/4W
△ R640	VK188400	R.FUS	330Ω	1/4W
△ R641	HZ003780	R.MTL.PLAT	0.22Ω+0.22	5W
△ R643	HV453470	R.CAR.FP	4.7Ω	1/4W
△ R646	HV453470	R.CAR.FP	4.7Ω	1/4W
△ R649	VK188400	R.FUS	330Ω	1/4W
△ R650	HZ003780	R.MTL.PLAT	0.22Ω+0.22	5W
△ R652	HV453470	R.CAR.FP	4.7Ω	1/4W
△ R655	VE009700	R.FUS	4.7Ω	1/4W
△ R659	HV453470	R.CAR.FP	4.7Ω	1/4W
△ R661	VE009700	R.FUS	4.7Ω	1/4W
△ R664	VE009700	R.FUS	4.7Ω	1/4W
△ R668	HV453470	R.CAR.FP	4.7Ω	1/4W
△ R670	VE009700	R.FUS	4.7Ω	1/4W
△ R676	HV453470	R.CAR.FP	4.7Ω	1/4W
△ R679	HV454100	R.CAR.FP	10Ω	1/4W
△ R680	HL314100	R.MTL.OXD	10Ω	1W
△ R681	HL314100	R.MTL.OXD	10Ω	1W
△ R683	HV454100	R.CAR.FP	10Ω	1/4W
△ R685	HL314100	R.MTL.OXD	10Ω	1W
△ R688	HL314100	R.MTL.OXD	10Ω	1W
△ R691	HL314100	R.MTL.OXD	10Ω	1W
R707	HV456820	R.CAR.FP	8.2KΩ	1/4W
△ R708	HV455100	R.CAR.FP	100Ω	1/4W
△ R709	HV453220	R.CAR.FP	2.2Ω	1/4W
△ R710	HL314330	R.MTL.OXD	33Ω	1W
△ R711	HV456330	R.CAR.FP	3.3KΩ	1/4W
△ R712	HV456470	R.CAR.FP	4.7KΩ	1/4W
△ R714	HL314100	R.MTL.OXD	10Ω	1W
△ R730	HV454100	R.CAR.FP	10Ω	1/4W
RY501	VK438300	RELAY	DH24D2-OT/M2	
RY502	VK438300	RELAY	DH24D2-OT/M2	
RY503	VK438300	RELAY	DH24D2-OT/M2	
RY726	VK438300	RELAY	DH24D2-OT/M2	
RY727	VK438300	RELAY	DH24D2-OT/M2	
* TE726	V4185300	TERM.SP	4P(UCRТА)	
* TE726	V4185400	TERM.SP	4P(BG)	
* TE727	V4185300	TERM.SP	4P(UCRТА)	
* TE727	V4185400	TERM.SP	4P(BG)	
* TE728	V4870200	TERM.SP	8P(UCRТА)	
* TE728	V4870300	TERM.SP	8P(BG)	
* TE729	V4870000	TERM.SP	4P(UCRТА)	
* TE729	V4870100	TERM.SP	4P(BG)	
VR501	VJ692700	VR.TRIM	B330Ω	
VR502	VJ692700	VR.TRIM	B330Ω	
VR503	VJ692700	VR.TRIM	B330Ω	
VR504	VJ692700	VR.TRIM	B330Ω	
VR505	VJ692700	VR.TRIM	B330Ω	
VR506	VJ692700	VR.TRIM	B330Ω	
VR507	VJ692900	VR.TRIM	B680Ω	
VR508	VJ692900	VR.TRIM	B680Ω	
	V3750100	PIN	L=50	
	BB071360	SCR.TERM	8.3x13	

* New Parts

Schm Ref.	PART NO.	Description		
	VK697600	SCR.BND.HD	3x10 SP ZMC2-Y	
*	V5001600	P.C.B.	VIDEO(UC)	
*	V5001700	P.C.B.	VIDEO(RT)	
*	V5001800	P.C.B.	VIDEO(A)	
*	V5001900	P.C.B.	VIDEO(BG)	
CB1	VB858200	CN.BS.PIN	3P	
CB2	VQ044700	CN.BS.PIN	16P	
CB3	VD004500	CN.BS.PIN	2P	
CB4	VD004600	CN.BS.PIN	3P	
CB151	VQ963300	CN.BS.PIN	12P	
CB152	VQ963300	CN.BS.PIN	12P	
CB153	LB919030	CN.BS.PIN	3P	
CB201	VF982300	CN.BS.PIN	17P	
CB202	VQ960900	CN.BS.PIN	6P	
CB261	VQ962700	CN.BS.PIN	6P	
CB331	VQ961500	CN.BS.PIN	12P	
CB332	VQ961500	CN.BS.PIN	12P	
CB333	VQ961500	CN.BS.PIN	12P	
CB334	VQ961500	CN.BS.PIN	12P	
* CB901	V4477700	CN.SOCKET	16P	
CB902	VQ047800	CN.BS.PIN	27P	
CB904	VD004500	CN.BS.PIN	2P	
C1	UB052100	C.CE.M.CHP	100pF	50V
C2	UB052100	C.CE.M.CHP	100pF	50V
C3	UB052100	C.CE.M.CHP	100pF	50V
C4	UB052100	C.CE.M.CHP	100pF	50V
C5	UB052100	C.CE.M.CHP	100pF	50V
C6	UB052100	C.CE.M.CHP	100pF	50V
C7	UB052100	C.CE.M.CHP	100pF	50V
C8	UB052100	C.CE.M.CHP	100pF	50V
C9	UB052100	C.CE.M.CHP	100pF	50V
C10	UB052100	C.CE.M.CHP	100pF	50V
* C11	UU147100	C.EL	10uF	25V
* C12	UU129100	C.EL	1000uF	10V
* C13	UU147100	C.EL	10uF	25V
* C14	UU129100	C.EL	1000uF	10V
* C15	UU137470	C.EL	47uF	16V
* C16	UU137470	C.EL	47uF	16V
C18	UB052820	C.CE.M.CHP	820pF	50V(ABG)
C18	UB053150	C.CE.M.CHP	1500pF	50V(UCRT)
* C19	UU127470	C.EL	47uF	10V
* C20	UU127470	C.EL	47uF	10V
* C21	UU127470	C.EL	47uF	10V
* C22	UU137470	C.EL	47uF	16V
* C23	UU137470	C.EL	47uF	16V
* C24	UU127470	C.EL	47uF	10V
* C25	UU127470	C.EL	47uF	10V
C26	UB052820	C.CE.M.CHP	820pF	50V
* C27	UU127470	C.EL	47uF	10V
C28	UB245100	C.CE.M.CHP	0.1uF	25V

* New Parts

P.C.B. VIDEO

Schm Ref.	PART NO.	Description		
C29	UB245100	C.CE.M.CHP	0.1uF	25V
* C30	UU127470	C.EL	47uF	10V
* C31	UU127470	C.EL	47uF	10V
* C32	VJ900600	C.CE.M.CHP	30pF	50V
* C33	VJ900600	C.CE.M.CHP	30pF	50V
C34	UB245100	C.CE.M.CHP	0.1uF	25V
C35	UB052470	C.CE.M.CHP	470pF	50V
C36	UB052120	C.CE.M.CHP	120pF	50V
C37	UB044100	C.CE.M.CHP	0.01uF	50V
* C38	UU127470	C.EL	47uF	10V
* C39	UU147100	C.EL	10uF	25V
C40	UB052820	C.CE.M.CHP	820pF	50V
C41	VJ898700	C.CE.M.CHP	2pF	50V(ABG)
C41	VJ900200	C.CE.M.CHP	20pF	50V(UCRT)
* C42	VJ898800	C.CE.M.CHP	3pF	50V(ABG)
C42	VJ899900	C.CE.M.CHP	15pF	50V(UCRT)
* C43	UU166470	C.EL	4.7uF	50V
C44	UB052220	C.CE.M.CHP	220pF	50V
* C45	UU147100	C.EL	10uF	25V
* C46	VJ900600	C.CE.M.CHP	30pF	50V
C47	UB052470	C.CE.M.CHP	470pF	50V
* C48	UU166470	C.EL	4.7uF	50V
C49	VJ899900	C.CE.M.CHP	15pF	50V
C50	UB245100	C.CE.M.CHP	0.1uF	25V
C51	UB245100	C.CE.M.CHP	0.1uF	25V
C52	UB245100	C.CE.M.CHP	0.1uF	25V
C151	UP652470	C.POL	470pF	100V
C152	UP652470	C.POL	470pF	100V
C153	UP652470	C.POL	470pF	100V
C154	UP652470	C.POL	470pF	100V
C155	UP652470	C.POL	470pF	100V
C156	UP652470	C.POL	470pF	100V
C157	UP652470	C.POL	470pF	100V
C158	UP652470	C.POL	470pF	100V
C159	UP652470	C.POL	470pF	100V
C160	UP652470	C.POL	470pF	100V
C161	UP652470	C.POL	470pF	100V
C162	UP652470	C.POL	470pF	100V
C163	UP652470	C.POL	470pF	100V
C164	UP652470	C.POL	470pF	100V
C165	UP652470	C.POL	470pF	100V
C166	UP652470	C.POL	470pF	100V
C167	UP652470	C.POL	470pF	100V
C168	UP652470	C.POL	470pF	100V
C169	UP652470	C.POL	470pF	100V
C170	UP652470	C.POL	470pF	100V
C171	UB052100	C.CE.M.CHP	100pF	50V
C172	UB245100	C.CE.M.CHP	0.1uF	25V
C173	UB245100	C.CE.M.CHP	0.1uF	25V
* C174	UU129100	C.EL	1000uF	10V
* C175	UU127470	C.EL	47uF	10V
* C176	UU127470	C.EL	47uF	10V
* C201	UU166100	C.EL	1uF	50V

* New Parts

Schm Ref.	PART NO.	Description		
* C202	VZ001600	C.MYLAR	0.047pF	50V
* C203	VZ001600	C.MYLAR	0.047pF	50V
* C204	VZ001600	C.MYLAR	0.047pF	50V
* C205	VZ001600	C.MYLAR	0.047pF	50V
* C206	UU166100	C.EL	1uF	50V
* C207	UU137470	C.EL	47uF	16V
C208	VQ645600	C.MYLAR	100pF	50V
* C209	UU166100	C.EL	1uF	50V
C210	VQ645600	C.MYLAR	100pF	50V
* C211	UU166100	C.EL	1uF	50V
* C212	UU137470	C.EL	47uF	16V
C213	VZ002000	C.MYLAR	0.1uF	50V
C214	UA654220	C.MYLAR	0.022uF	50V
C215	UA654220	C.MYLAR	0.022uF	50V
C216	VZ002000	C.MYLAR	0.1uF	50V
* C217	UU137100	C.EL	10uF	16V
C218	VQ645600	C.MYLAR	100pF	50V
C219	VQ645600	C.MYLAR	100pF	50V
* C220	UU137100	C.EL	10uF	16V
* C221	UU137100	C.EL	10uF	16V
* C222	UU147220	C.EL	22uF	25V
* C223	UU147220	C.EL	22uF	25V
* C224	UU137100	C.EL	10uF	16V
* C225	UU137100	C.EL	10uF	16V
* C226	UU137100	C.EL	10uF	16V
* C227	UU137330	C.EL	33uF	16V
C228	FG212100	C.CE	100pF	50V
C229	FG212100	C.CE	100pF	50V
* C230	UU118100	C.EL	100uF	6.3V
* C231	UU118100	C.EL	100uF	6.3V
C232	FG212100	C.CE	100pF	50V
C233	FG212100	C.CE	100pF	50V
* C234	UU137330	C.EL	33uF	16V
* C235	UU139100	C.EL	1000uF	16V
C236	FG251220	C.CE	22pF	50V
C237	FG251220	C.CE	22pF	50V
* C238	UU139100	C.EL	1000uF	16V
C261	VF467000	C.CE.TUBLR	1000pF	50V
C262	VF467000	C.CE.TUBLR	1000pF	50V
C263	VF467000	C.CE.TUBLR	1000pF	50V
C264	VF467300	C.CE.TUBLR	0.01uF	16V
C381	VF466900	C.CE.TUBLR	470pF	50V
C382	VF467300	C.CE.TUBLR	0.01uF	16V
C383	VF466900	C.CE.TUBLR	470pF	50V
C384	VF467300	C.CE.TUBLR	0.01uF	16V
C921	UT452470	C.PP	470pF	100V
C922	UT452470	C.PP	470pF	100V
C925	UT452470	C.PP	470pF	100V
C926	UT452470	C.PP	470pF	100V
* C928	UU147100	C.EL	10uF	25V
C929	VR169200	C.MYLAR.ML	ECQ-V1H474JL3	
C930	VR169200	C.MYLAR.ML	ECQ-V1H474JL3	
* C931	UU147100	C.EL	10uF	25V

* New Parts

P.C.B. VIDEO

Schm Ref.	PART NO.	Description
C932	VR169200	C.MYLAR.ML ECQ-V1H474JL3
* C934	UU147100	C.EL 10uF 25V
C935	UT452470	C.PP 470pF 100V
C936	UT452470	C.PP 470pF 100V
* C939	V5376400	C.PP 100pF 100V
* C940	V5376400	C.PP 100pF 100V
C943	UB044100	C.CE.M.CHP 0.01uF 50V
C945	UB044100	C.CE.M.CHP 0.01uF 50V
C946	UB044100	C.CE.M.CHP 0.01uF 50V
* C954	V5376500	C.PP 220pF 100V
* C957	V5376500	C.PP 220pF 100V
* C960	V5376500	C.PP 220pF 100V
D1	iF004600	DIODE 1SS133
D2	iF004600	DIODE 1SS133
D4	iF004600	DIODE 1SS133
D5	iF004600	DIODE 1SS133
D6	VG435100	DIODE.ZENR MTZJ2.0B 2.0V
D7	iF004600	DIODE 1SS133
D8	iF004600	DIODE 1SS133
D9	iF004600	DIODE 1SS133
D10	iF004600	DIODE 1SS133
D11	iF004600	DIODE 1SS133
D12	iF004600	DIODE 1SS133
D13	iF004600	DIODE 1SS133
D201	VU264100	DIODE 1SR139-400
D202	VU264100	DIODE 1SR139-400
D901	VT332900	DIODE 1SS355
D902	VT332900	DIODE 1SS355
D903	VT332900	DIODE 1SS355
D904	VT332900	DIODE 1SS355
D905	VT332900	DIODE 1SS355
* IC1	XW911A00	IC LA7108M VIDEO AMP
IC4	XL493A00	IC TC74HC4051AP
IC5	XL493A00	IC TC74HC4051AP
IC6	XL493A00	IC TC74HC4051AP
IC7	XL493A00	IC TC74HC4051AP
IC8	iR405300	IC TC74HC4053AP
IC9	iR405300	IC TC74HC4053AP
* IC10	XW911A00	IC LA7108M VIDEO AMP
* IC11	XW911A00	IC LA7108M VIDEO AMP
* IC12	XW460A00	IC M35013-079SP
IC13	iG142200	IC TC74HCU04AP
IC14	iG142200	IC TC74HCU04AP
* IC15	XW416A00	IC BU2092 SER/PAR
IC201	XM356A00	IC NJM2068LD
IC202	XB247301	IC uPC4570HA
IC203	XP844A00	IC NJM4556AL
JK1	VU144900	CN.DIN 2P
JK2	VU144900	CN.DIN 2P
JK3	VU144900	CN.DIN 2P
JK4	VU144900	CN.DIN 2P
JK5	VU144900	CN.DIN 2P
JK6	VU144500	CN.DIN 2P

* New Parts

Schm Ref.	PART NO.	Description
* JK261	V4164400	JACK.PHONE YKB21-5209
JK381	V2589500	CN 1P
L1	V2725700	COIL 15uH
L2	V3233700	COIL 1.5uH
* PJ151	V4806900	JACK.PIN 4P
* PJ152	V4806800	JACK.PIN 6P
* PJ153	V4806900	JACK.PIN 4P
* PJ154	V4806800	JACK.PIN 6P
PJ155	VU144200	JACK.PIN 1P
PJ381	VU459400	JACK.PIN 3P
* PJ901	V4583900	JACK.PIN 3P
* PJ902	V4583900	JACK.PIN 3P
* PJ903	V4583900	JACK.PIN 3P
* PJ904	V4583900	JACK.PIN 3P
* PJ905	V4548500	JACK.PIN 2P
* PJ906	V4548500	JACK.PIN 2P
* PJ907	V4912200	JACK.PIN 2P
* PJ908	V4806700	JACK.PIN 2P
* PJ909	V4806700	JACK.PIN 2P
* PJ910	V4548500	JACK.PIN 2P
* PJ911	V4548500	JACK.PIN 2P
Q1	iC174020	TR 2SC1740S R,S
Q2	iC174020	TR 2SC1740S R,S
Q3	iC287820	TR 2SC2878 A,B
Q4	iC174020	TR 2SC1740S R,S
Q5	iC174020	TR 2SC1740S R,S
Q6	VD678700	TR.DGT DTC114ES
Q7	iC174020	TR 2SC1740S R,S
Q8	iA101521	TR 2SA1015 Y
Q9	iC224030	TR 2SC2240 GR,BL
Q10	iC053540	TR 2SC535 A,B,C
Q11	iC224030	TR 2SC2240 GR,BL
Q12	iC287820	TR 2SC2878 A,B
Q151	iC174020	TR 2SC1740S R,S
Q201	VK432900	TR 2SD1915F S,T
Q202	VK432900	TR 2SD1915F S,T
Q901	VZ725900	TR 2SD1938F S,T
Q902	VZ725900	TR 2SD1938F S,T
Q903	VZ725900	TR 2SD1938F S,T
Q904	VZ725900	TR 2SD1938F S,T
Q905	VK432900	TR 2SD1915F S,T
Q906	VK432900	TR 2SD1915F S,T
Q907	VZ725900	TR 2SD1938F S,T
Q908	VZ725900	TR 2SD1938F S,T
Q909	VZ725900	TR 2SD1938F S,T
Q910	VZ725900	TR 2SD1938F S,T
Q911	VZ725900	TR 2SD1938F S,T
Q912	VZ725900	TR 2SD1938F S,T
Q913	VZ725900	TR 2SD1938F S,T
Q914	VZ725900	TR 2SD1938F S,T
Q915	VZ725900	TR 2SD1938F S,T
Q916	VZ725900	TR 2SD1938F S,T
Q917	VZ725900	TR 2SD1938F S,T

* New Parts

P.C.B. VIDEO

Schm Ref.	PART NO.	Description
Q918	VZ725900	TR 2SD1938F S,T
Q919	VZ725900	TR 2SD1938F S,T
Q920	VZ725900	TR 2SD1938F S,T
Q921	VZ725900	TR 2SD1938F S,T
* Q922	V5224700	TR 2SD1383K A,B
* Q923	VV655600	TR.DGT DTC143EKA TP
* Q924	VV655600	TR.DGT DTC143EKA TP
Q926	VZ725900	TR 2SD1938F S,T
Q927	VZ725900	TR 2SD1938F S,T
Q928	VZ725900	TR 2SD1938F S,T
R152	Vi199200	R.MTL.CHP 56KΩ 1/10W
R153	Vi199200	R.MTL.CHP 56KΩ 1/10W
R156	Vi199200	R.MTL.CHP 56KΩ 1/10W
R157	Vi199200	R.MTL.CHP 56KΩ 1/10W
R160	Vi199200	R.MTL.CHP 56KΩ 1/10W
R161	Vi199200	R.MTL.CHP 56KΩ 1/10W
R164	Vi199200	R.MTL.CHP 56KΩ 1/10W
R165	Vi199200	R.MTL.CHP 56KΩ 1/10W
R168	Vi199200	R.MTL.CHP 56KΩ 1/10W
R169	Vi199200	R.MTL.CHP 56KΩ 1/10W
R174	Vi199200	R.MTL.CHP 56KΩ 1/10W
R175	Vi199200	R.MTL.CHP 56KΩ 1/10W
R180	Vi199200	R.MTL.CHP 56KΩ 1/10W
R181	Vi199200	R.MTL.CHP 56KΩ 1/10W
R201	HV453330	R.CAR.FP 3.3Ω 1/4W
R206	HV453330	R.CAR.FP 3.3Ω 1/4W
R231	HV455220	R.CAR.FP 220Ω 1/4W
R239	HV455220	R.CAR.FP 220Ω 1/4W
R240	HV455100	R.CAR.FP 100Ω 1/4W
R243	HV455100	R.CAR.FP 100Ω 1/4W
R917	Vi194200	R.MTL.CHP 510Ω 1/10W
R918	Vi198200	R.MTL.CHP 22KΩ 1/10W
R919	Vi198200	R.MTL.CHP 22KΩ 1/10W
R920	Vi194200	R.MTL.CHP 510Ω 1/10W
R921	Vi194200	R.MTL.CHP 510Ω 1/10W
R922	Vi198200	R.MTL.CHP 22KΩ 1/10W
R923	Vi198200	R.MTL.CHP 22KΩ 1/10W
R924	Vi194200	R.MTL.CHP 510Ω 1/10W
R925	Vi194200	R.MTL.CHP 510Ω 1/10W
R926	Vi198200	R.MTL.CHP 22KΩ 1/10W
R927	Vi198200	R.MTL.CHP 22KΩ 1/10W
R928	Vi194200	R.MTL.CHP 510Ω 1/10W
R929	Vi198200	R.MTL.CHP 22KΩ 1/10W
R930	Vi194200	R.MTL.CHP 510Ω 1/10W
R931	Vi194200	R.MTL.CHP 510Ω 1/10W
R932	Vi198200	R.MTL.CHP 22KΩ 1/10W
R933	Vi198200	R.MTL.CHP 22KΩ 1/10W
R934	Vi194200	R.MTL.CHP 510Ω 1/10W
R936	Vi198200	R.MTL.CHP 22KΩ 1/10W
R937	Vi198200	R.MTL.CHP 22KΩ 1/10W
R939	Vi194100	R.MTL.CHP 470Ω 1/10W
R945	Vi194100	R.MTL.CHP 470Ω 1/10W
R951	Vi194100	R.MTL.CHP 470Ω 1/10W

* New Parts

Schm Ref.	PART NO.	Description
R957	Vi194100	R.MTL.CHP 470Ω 1/10W
R961	Vi194100	R.MTL.CHP 470Ω 1/10W
R963	Vi194100	R.MTL.CHP 470Ω 1/10W
R970	Vi194100	R.MTL.CHP 470Ω 1/10W
R975	Vi194100	R.MTL.CHP 470Ω 1/10W
R991	Vi194100	R.MTL.CHP 470Ω 1/10W
R992	Vi194100	R.MTL.CHP 470Ω 1/10W
R995	Vi194100	R.MTL.CHP 470Ω 1/10W
R996	Vi194100	R.MTL.CHP 470Ω 1/10W
R999	Vi194100	R.MTL.CHP 470Ω 1/10W
* RY901	V4785600	RELAY DC AGN2004H
* RY902	V4785600	RELAY DC AGN2004H
* RY903	V4785600	RELAY DC AGN2004H
* RY904	V4785600	RELAY DC AGN2004H
* RY905	V4785600	RELAY DC AGN2004H
* RY906	V4785600	RELAY DC AGN2004H
* SW201	V4746100	SW.PUSH SPUN22 2
* SW202	V4104600	SW.RT.ENC SDB161PH20F-1-4-14
* SW351	V4757100	SW.TACT EVQ11A
* SW352	V4757100	SW.TACT EVQ11A
* SW353	V4757100	SW.TACT EVQ11A
* SW354	V4757100	SW.TACT EVQ11A
* SW355	V4757100	SW.TACT EVQ11A(UCA)
* SW356	V4757100	SW.TACT EVQ11A(UCA)
* SW357	V4757100	SW.TACT EVQ11A
* SW358	V4757100	SW.TACT EVQ11A
* SW359	V4757100	SW.TACT EVQ11A
* SW360	V4757100	SW.TACT EVQ11A(UCA)
* SW361	V4757100	SW.TACT EVQ11A(UCA)
* SW362	V4757100	SW.TACT EVQ11A
* SW363	V4757100	SW.TACT EVQ11A
* SW990	V5089500	SW.RT.ENC REB162(9X5)RVB
* SW991	V4859300	SW.RT.ENC
* VR201	V4104700	VR 16KΩ
* VR202	V4104800	VR 20KΩ
VR203	VU145000	VR MN30KΩ
XL1	VD980900	RSNR.CRYS 14.3181MHz(UCRT)
XL1	VV949900	RSNR.CRYS 17.734475MHz(ABG)
	V3750100	PIN L=50
	BB071360	SCR.TERM 8.3x13

* New Parts

P.C.B. SUB TRANS

Schm Ref.	PART NO.	Description
*	V5002100	P.C.B. SUB TRANS.(U)
*	V5002200	P.C.B. SUB TRANS.(C)
*	V5002300	P.C.B. SUB TRANS.(RT)
*	V5002400	P.C.B. SUB TRANS.(A)
*	V5003500	P.C.B. SUB TRANS.(B)
*	V5003600	P.C.B. SUB TRANS.(G)
	CB101	VQ960700 CN 4P
	CB111	VQ962500 CN.BS.PIN 4P
	CB112	VD004500 CN.BS.PIN 2P
*	CB113	V4864900 CN.BS.PIN 16P
	CB481	LA002390 TERM.WRAP 2P
	CB482	LA002400 TERM.WRAP 3P L-753B
	CB483	VL845100 CN.BS.PIN 7P
	CB751	VG879900 CN.BS.PIN 2P
	CB753	VS996100 HOLDER.FUS EYF64BC(UCRT)
	CB754	VP206500 HOLDER.FUS EYF-52BC(ABG)
	CB755	VP206500 HOLDER.FUS EYF-52BC(ABG)
	CB755	VS996100 HOLDER.FUS EYF64BC(UCRT)
	CB756	LA002410 TERM.WRAP 2P
	CB757	VP206500 HOLDER.FUS EYF-52BC(RTG)
	CB758	VP206500 HOLDER.FUS EYF-52BC(RTG)
	CB759	LA002410 TERM.WRAP 2P(RT)
*	CB801	V4476100 CN.BS.PIN 16P
	C111	UB052100 C.CE.M.CHP 100pF 50V
	C112	UB052100 C.CE.M.CHP 100pF 50V
	C113	UB052100 C.CE.M.CHP 100pF 50V
	C114	UB052100 C.CE.M.CHP 100pF 50V
*	C115	UU129100 C.EL 1000uF 10V
*	C116	UU129100 C.EL 1000uF 10V
	C117	UB052100 C.CE.M.CHP 100pF 50V
*	C118	UU137470 C.EL 47uF 16V
*	C119	UU137470 C.EL 47uF 16V
*	C120	UU137470 C.EL 47uF 16V
*	C121	UU127470 C.EL 47uF 10V
*	C122	UU127470 C.EL 47uF 10V
*	C123	UU127470 C.EL 47uF 10V
*	C124	UU127470 C.EL 47uF 10V
*	C125	UU147100 C.EL 10uF 25V
	C126	UB445470 C.CE.M.CHP 0.47uF 16V
	C127	UB445470 C.CE.M.CHP 0.47uF 16V
*	C128	UU127470 C.EL 47uF 10V
	C129	UB445470 C.CE.M.CHP 0.47uF 16V
	C481	UT454270 C.PP 0.027uF 100V
	C482	UT454270 C.PP 0.027uF 100V
	C483	Vi862200 C.POLY 0.1uF 100V
	C484	Vi862200 C.POLY 0.1uF 100V
	C485	VR168300 C.MYLAR.ML ECQ-V1H104JL3
*	C751	UU149100 C.EL 1000uF 25V
*	C752	UU147100 C.EL 10uF 25V(RT)
*	C753	UU167100 C.EL 10uF 50V(RT)
*	C754	UU197470 C.EL 47uF 100V(RT)
	C755	Vi716700 C.MYLAR 0.01uF 50V(UCABG)
	C756	Vi716700 C.MYLAR 0.01uF 50V(RT)

* New Parts

Schm Ref.	PART NO.	Description
	C757	Vi716700 C.MYLAR 0.01uF 50V(RT)
	C758	VV975400 C.CE 0.01uF 275V
	C759	VV975400 C.CE 0.01uF 275V(C)
*	C801	UU167100 C.EL 10uF 50V
*	C802	V5376400 C.PP 100pF 100V
*	C803	UU167100 C.EL 10uF 50V
*	C804	V5376400 C.PP 100pF 100V
*	C805	UU167100 C.EL 10uF 50V
*	C806	V5376400 C.PP 100pF 100V
*	C807	V5376400 C.PP 100pF 100V
*	C808	UU137470 C.EL 47uF 16V
	C809	UA653100 C.MYLAR 1000pF 50V
*	C810	UU137470 C.EL 47uF 16V
*	C811	V5376400 C.PP 100pF 100V
*	C812	UU137470 C.EL 47uF 16V
	C813	UA653100 C.MYLAR 1000pF 50V
*	C814	UU167100 C.EL 10uF 50V
*	C815	V5376400 C.PP 100pF 100V
*	C816	UU128100 C.EL 100uF 10V
	C817	UT453100 C.PP 1000pF 100V
	C818	VR516400 C.CE 15pF 500V
	C819	VR516400 C.CE 15pF 500V
	C820	FU451150 C.MICA 15pF 500V
*	C821	UU167100 C.EL 10uF 50V
*	C822	UU167100 C.EL 10uF 50V
*	C823	V5376400 C.PP 100pF 100V
*	C824	UU167100 C.EL 10uF 50V
*	C825	UU167100 C.EL 10uF 50V
*	C826	V5376400 C.PP 100pF 100V
*	C827	UU167100 C.EL 10uF 50V
*	C828	UU167100 C.EL 10uF 50V
*	C829	V5376400 C.PP 100pF 100V
*	C830	UU166330 C.EL 3.3uF 50V
*	C831	V5376400 C.PP 100pF 100V
*	C832	UU128100 C.EL 100uF 10V
	C833	UT453100 C.PP 1000pF 100V
*	C834	V5376400 C.PP 100pF 100V
*	C835	UU128100 C.EL 100uF 10V
	C836	UT453100 C.PP 1000pF 100V
*	C837	V5376400 C.PP 100pF 100V
*	C838	UU128100 C.EL 100uF 10V
	C839	UT453100 C.PP 1000pF 100V
	C840	FU451150 C.MICA 15pF 500V
	C841	FU451150 C.MICA 15pF 500V
	C842	FU451150 C.MICA 15pF 500V
*	C843	UU167100 C.EL 10uF 50V
*	C844	UU167100 C.EL 10uF 50V
*	C846	V5376400 C.PP 100pF 100V
*	C848	V5376400 C.PP 100pF 100V
*	C850	V5376400 C.PP 100pF 100V
*	C852	V5376400 C.PP 100pF 100V
*	C854	V5376400 C.PP 100pF 100V
*	C855	UU118100 C.EL 100uF 6.3V

* New Parts

P.C.B. SUB TRANS

Schm Ref.	PART NO.	Description
* C856	UU137220	C.EL 22uF 16V
△ D481	VR253700	DIODE.BRG S1NB20 1.0A 200V
△* D482	V4870400	DIODE.BRG D4SBS4 4.0A
D751	iF004600	DIODE 1SS133
D752	iF004600	DIODE 1SS133(RT)
D753	VU264100	DIODE 1SR139-400(RT)
△ D754	VR253700	DIODE.BRG S1NB20 1.0A 200V
D755	VG439900	DIODE.ZENR MTZJ11B 11V(RT)
D756	iF004600	DIODE 1SS133(C)
D801	VG440300	DIODE.ZENR MTZJ12C 12V
D802	VU647200	DIODE.SHOT RB441Q-40 T-77
D803	iF004600	DIODE 1SS133
D804	iF004600	DIODE 1SS133
△ F751	KB001760	FUSE 6.3A 250V(ABG)
△ F751	VU238300	FUSE 12A 250V(UCRT)
△ F752	KB001760	FUSE 6.3A 250V(RT)
△ F752	VT942900	FUSE TH2.5A 250V(G)
* HS481	V4804600	HEAT.SINK DPS35-40
HS751	VS605900	HEAT.SINK DPS15-45(RT)
IC111	XL493A00	IC TC74HC4051AP
IC112	XL493A00	IC TC74HC4051AP
IC113	iR405300	IC TC74HC4053AP
* IC114	XW911A00	IC LA7108M VIDEO AMP
* PJ101	V4715500	JACK.PIN 3P
PJ111	VL834600	JACK.PIN 2P
PJ112	VL834600	JACK.PIN 2P
PJ113	VL834600	JACK.PIN 2P
PJ114	VL834600	JACK.PIN 2P
PJ115	VU144200	JACK.PIN 1P
Q111	iC174020	TR 2SC1740S R,S
Q112	iC174020	TR 2SC1740S R,S
Q751	VD488500	TR.DGT DTC143XS
△ Q752	VR510800	TR 2SD2396 J,K(RT)
△ Q753	VR510800	TR 2SD2396 J,K(RT)
Q754	iE102620	FET 2SK246 Y(RT)
Q755	iC174020	TR 2SC1740S R,S
Q756	iC174020	TR 2SC1740S R,S(C)
Q801	iA097000	TR 2SA970 GR,BL
Q802	iA097000	TR 2SA970 GR,BL
Q803	iA097000	TR 2SA970 GR,BL
Q804	iA097000	TR 2SA970 GR,BL
Q805	iA097000	TR 2SA970 GR,BL
Q806	iA097000	TR 2SA970 GR,BL
Q807	iC1815C0	TR 2SC1815 Y
Q808	iC1815C0	TR 2SC1815 Y
Q809	iC1815C0	TR 2SC1815 Y
Q810	iC1815C0	TR 2SC1815 Y
Q811	iC1815C0	TR 2SC1815 Y
Q812	iA097000	TR 2SA970 GR,BL
Q813	iA097000	TR 2SA970 GR,BL
Q814	iA097000	TR 2SA970 GR,BL
Q815	iC1815C0	TR 2SC1815 Y
Q816	iC1815C0	TR 2SC1815 Y

* New Parts

Schm Ref.	PART NO.	Description
Q817	iC1815C0	TR 2SC1815 Y
Q818	iA097000	TR 2SA970 GR,BL
Q819	iA097000	TR 2SA970 GR,BL
Q820	iC1815C0	TR 2SC1815 Y
Q821	iC1815C0	TR 2SC1815 Y
Q822	iC1815C0	TR 2SC1815 Y
Q823	iA097000	TR 2SA970 GR,BL
Q824	iA097000	TR 2SA970 GR,BL
Q825	iC1815C0	TR 2SC1815 Y
Q826	iC1815C0	TR 2SC1815 Y
Q827	iC1815C0	TR 2SC1815 Y
△ R820	HV455220	R.CAR.FP 220Ω 1/4W
△ R821	HV455220	R.CAR.FP 220Ω 1/4W
△ R825	HV454470	R.CAR.FP 47Ω 1/4W
△ R829	HV454470	R.CAR.FP 47Ω 1/4W
△ R831	HV455100	R.CAR.FP 100Ω 1/4W
△ R843	HV455220	R.CAR.FP 220Ω 1/4W
△ R844	HV455220	R.CAR.FP 220Ω 1/4W
△ R850	HV455220	R.CAR.FP 220Ω 1/4W
△ R851	HV455220	R.CAR.FP 220Ω 1/4W
△ R857	HV455220	R.CAR.FP 220Ω 1/4W
△ R858	HV455220	R.CAR.FP 220Ω 1/4W
△ R860	HV455100	R.CAR.FP 100Ω 1/4W
△ R862	HV455100	R.CAR.FP 100Ω 1/4W
△ R864	HV455100	R.CAR.FP 100Ω 1/4W
△ RY751	V2695300	RELAY DC DG12D1-O/M-II
△ RY752	V2712300	RELAY DC SDT-S-112LMR(C)
△* T751	XW973A00	TRANS.PWR (UC)
△* T751	XW974A00	TRANS.PWR (RT)
△* T751	XW975A00	TRANS.PWR (A)
△* T751	XW976A00	TRANS.PWR (BG)
△* TE751	V4746500	OUTLET.AC 3P(RT)
△ TE751	VT915000	OUTLET.AC 2P(A)
△ TE751	VU543300	OUTLET.AC 1P(B)
△ TE751	VV118800	OUTLET.AC 3P(UC)
△ TE751	VV118800	OUTLET.AC 3P(UC)
△ TE751	VV119000	OUTLET.AC 3P(G)
TH601	VM842400	POSISTOR PTH9M04 BE/90°C
	BB071360	SCR.TERM 8.3x13
	VK697600	SCR.BND.HD 3x10 SP ZMC2-Y

* New Parts

P.C.B. FUNCTION

Schm Ref.	PART NO.	Description		
*	V5002600	P.C.B.	FUNCTION(UC)	
*	V5002700	P.C.B.	FUNCTION(RT)	
*	V5002800	P.C.B.	FUNCTION(A)	
*	V5002900	P.C.B.	FUNCTION(BG)	
	CB1	VB858200	CN.BS.PIN	3P
	CB2	VQ963300	CN.BS.PIN	12P
	CB3	VQ963300	CN.BS.PIN	12P
	CB4	VM859700	CN.BS.PIN	16P
	CB5	VQ044600	CN.BS.PIN	13P(UCA)
	CB6	VP682300	CN.BS.PIN	8P
	CB7	VD004500	CN.BS.PIN	2P
	CB8	VB858200	CN.BS.PIN	3P
	CB9	VQ044500	CN.BS.PIN	11P
	CB10	VF982300	CN.BS.PIN	17P
	CB11	VP682300	CN.BS.PIN	8P
	CB12	VQ045600	CN.BS.PIN	27P
	CB13	VB858200	CN.BS.PIN	3P
	CB14	VB858400	CN.BS.PIN	5P
	CB15	VB858500	CN.BS.PIN	6P
	CB16	VQ044700	CN.BS.PIN	16P
	CB17	VB858300	CN.BS.PIN	4P
*	CB351	V3768800	SOCKET	17LE-23090-28
	CB352	VQ044500	CN.BS.PIN	11P
	C1	VD930900	C.CE.SMI	0.1uF 25V
	C4	UB245100	C.CE.M.CHP	0.1uF 25V
	C5	UB245100	C.CE.M.CHP	0.1uF 25V
*	C6	UU166100	C.EL	1uF 50V
	C7	UP652220	C.POL	220pF 100V
	C10	UP652220	C.POL	220pF 100V
*	C11	UU166100	C.EL	1uF 50V
	C12	UP652470	C.POL	470pF 100V
	C13	UP652470	C.POL	470pF 100V
	C14	UP652470	C.POL	470pF 100V(RTBG)
	C15	UP652470	C.POL	470pF 100V(RTBG)
	C16	UP652470	C.POL	470pF 100V
	C17	UP652470	C.POL	470pF 100V
	C18	UP652470	C.POL	470pF 100V
	C19	UP652470	C.POL	470pF 100V
	C20	UP652470	C.POL	470pF 100V
	C21	UP652470	C.POL	470pF 100V
	C22	UP652470	C.POL	470pF 100V
	C23	UP652470	C.POL	470pF 100V
*	C24	UU166470	C.EL	4.7uF 50V
	C25	UP652470	C.POL	470pF 100V
	C26	UP652470	C.POL	470pF 100V
*	C27	UU166470	C.EL	4.7uF 50V
*	C28	UU166470	C.EL	4.7uF 50V
	C29	UP652470	C.POL	470pF 100V
	C30	UP652470	C.POL	470pF 100V
*	C31	UU166470	C.EL	4.7uF 50V
*	C32	UU166470	C.EL	4.7uF 50V
	C33	UP652470	C.POL	470pF 100V
	C34	UP652470	C.POL	470pF 100V

* New Parts

Schm Ref.	PART NO.	Description			
*	C35	UU166470	C.EL	4.7uF	50V
	C36	UP652470	C.POL	470pF	100V
	C37	UP652470	C.POL	470pF	100V
*	C38	UU147100	C.EL	10uF	25V
	C39	UA654390	C.MYLAR	0.039uF	50V
	C40	UA654110	C.MYLAR	0.011uF	50V
*	C41	UU118220	C.EL	220uF	6.3V
*	C42	UU118220	C.EL	220uF	6.3V
	C43	UA654390	C.MYLAR	0.039uF	50V
	C44	UA654110	C.MYLAR	0.011uF	50V
*	C45	UU147100	C.EL	10uF	25V
*	C46	UU166220	C.EL	2.2uF	50V
	C47	UP652100	C.POL	100pF	100V
	C48	UP652100	C.POL	100pF	100V
*	C49	UU166220	C.EL	2.2uF	50V
*	C50	UU147100	C.EL	10uF	25V
*	C51	UU147100	C.EL	10uF	25V
*	C52	UU147100	C.EL	10uF	25V
*	C53	UU147100	C.EL	10uF	25V
*	C54	UU147100	C.EL	10uF	25V
*	C55	UU147100	C.EL	10uF	25V
*	C56	UU137470	C.EL	47uF	16V
	C57	UP652100	C.POL	100pF	100V
	C58	UP652100	C.POL	100pF	100V
*	C59	UU137470	C.EL	47uF	16V
*	C60	UU138100	C.EL	100uF	16V
*	C61	UU137470	C.EL	47uF	16V
	C62	UA653100	C.MYLAR	1000pF	50V
	C63	UA653100	C.MYLAR	1000pF	50V
*	C64	UU138100	C.EL	100uF	16V
*	C65	UU137470	C.EL	47uF	16V
*	C66	UU147100	C.EL	10uF	25V
*	C67	UU166470	C.EL	4.7uF	50V
*	C68	UU166470	C.EL	4.7uF	50V
*	C69	UU147100	C.EL	10uF	25V
*	C70	UU147100	C.EL	10uF	25V
*	C71	UU147100	C.EL	10uF	25V
*	C72	UU147100	C.EL	10uF	25V
*	C73	UU137470	C.EL	47uF	16V
*	C74	UU137470	C.EL	47uF	16V
*	C75	UU166100	C.EL	1uF	50V
*	C76	UU137470	C.EL	47uF	16V
*	C77	UU166100	C.EL	1uF	50V
*	C78	UU137470	C.EL	47uF	16V
*	C79	UU166100	C.EL	1uF	50V
*	C80	UU137470	C.EL	47uF	16V
*	C81	UU147100	C.EL	10uF	25V
*	C82	UU147100	C.EL	10uF	25V
*	C83	UU137470	C.EL	47uF	16V
*	C84	UU166470	C.EL	4.7uF	50V
	C85	UP652100	C.POL	100pF	100V
*	C86	UU166470	C.EL	4.7uF	50V
	C87	UP652100	C.POL	100pF	100V

* New Parts

P.C.B. FUNCTION

Schm Ref.	PART NO.	Description		
* C88	UU137220	C.EL	22uF	16V
C89	UP654270	C.POL	0.027uF	100V
C90	UP654270	C.POL	0.027uF	100V
* C91	UU137220	C.EL	22uF	16V
* C92	UU147100	C.EL	10uF	25V
* C93	UU147100	C.EL	10uF	25V
* C94	UU147100	C.EL	10uF	25V
* C95	UU147100	C.EL	10uF	25V
* C96	UU147100	C.EL	10uF	25V
* C97	UU147100	C.EL	10uF	25V
* C98	UU147100	C.EL	10uF	25V
* C99	UU147100	C.EL	10uF	25V
* C100	UU147100	C.EL	10uF	25V
* C101	UU147100	C.EL	10uF	25V
* C102	UU166220	C.EL	2.2uF	50V
* C103	UU166220	C.EL	2.2uF	50V
C104	UB245100	C.CE.M.CHP	0.1uF	25V(UCA)
C105	UP654270	C.POL	0.027uF	100V
* C106	UU147100	C.EL	10uF	25V
* C107	UU147100	C.EL	10uF	25V
C108	UP654270	C.POL	0.027uF	100V
* C109	UU147100	C.EL	10uF	25V
* C110	UU147100	C.EL	10uF	25V
* C111	UU147100	C.EL	10uF	25V
* C112	UU147100	C.EL	10uF	25V
* C113	UU147100	C.EL	10uF	25V
* C114	UU147100	C.EL	10uF	25V
* C115	UU147100	C.EL	10uF	25V
* C116	UU147100	C.EL	10uF	25V
* C117	UU147100	C.EL	10uF	25V
* C118	UU147100	C.EL	10uF	25V
C119	UB245100	C.CE.M.CHP	0.1uF	25V
* C120	UU118100	C.EL	100uF	6.3V
C121	UB245100	C.CE.M.CHP	0.1uF	25V
C122	UB245100	C.CE.M.CHP	0.1uF	25V
C123	UB245100	C.CE.M.CHP	0.1uF	25V
C124	UB245100	C.CE.M.CHP	0.1uF	25V
C125	UB245100	C.CE.M.CHP	0.1uF	25V
C127	UB245100	C.CE.M.CHP	0.1uF	25V
C128	UB245100	C.CE.M.CHP	0.1uF	25V
C130	UB245100	C.CE.M.CHP	0.1uF	25V
* C131	UU118100	C.EL	100uF	6.3V
C132	UB245100	C.CE.M.CHP	0.1uF	25V
C133	UB245100	C.CE.M.CHP	0.1uF	25V
C134	UB245100	C.CE.M.CHP	0.1uF	25V
C135	UB245100	C.CE.M.CHP	0.1uF	25V
* C136	UU118100	C.EL	100uF	6.3V
C137	UB245100	C.CE.M.CHP	0.1uF	25V
C138	UB245100	C.CE.M.CHP	0.1uF	25V
* C140	UU137470	C.EL	47uF	16V
C141	UB245100	C.CE.M.CHP	0.1uF	25V
C142	UB245100	C.CE.M.CHP	0.1uF	25V
C143	UB245100	C.CE.M.CHP	0.1uF	25V

* New Parts

Schm Ref.	PART NO.	Description		
C144	UB245100	C.CE.M.CHP	0.1uF	25V
C145	UB245100	C.CE.M.CHP	0.1uF	25V
C146	UB245100	C.CE.M.CHP	0.1uF	25V
C147	UB245100	C.CE.M.CHP	0.1uF	25V
C148	UB245100	C.CE.M.CHP	0.1uF	25V
C149	UB245100	C.CE.M.CHP	0.1uF	25V
C150	UP652100	C.POL	100pF	100V
C151	UP652100	C.POL	100pF	100V
* C152	UU147100	C.EL	10uF	25V
* C153	UU147100	C.EL	10uF	25V
* C154	UU147100	C.EL	10uF	25V
* C155	UU147100	C.EL	10uF	25V
* C156	UU137470	C.EL	47uF	16V
* C157	UU137470	C.EL	47uF	16V
C159	UP652100	C.POL	100pF	100V
C160	UP652100	C.POL	100pF	100V
* C162	UU147100	C.EL	10uF	25V(U CABG)
* C162	UU168100	C.EL	100uF	50V(RT)
* C163	UU165470	C.EL	0.47uF	50V
C164	UB245100	C.CE.M.CHP	0.1uF	25V
* C165	UU137470	C.EL	47uF	16V
* C170	UU137470	C.EL	47uF	16V
C171	UP652100	C.POL	100pF	100V
C174	UP652100	C.POL	100pF	100V
C175	VU545000	C.EL	47000uF	5.5V
* C176	UU119100	C.EL	1000uF	6.3V
* C177	UU137470	C.EL	47uF	16V
C178	UB245100	C.CE.M.CHP	0.1uF	25V
* C179	UU119100	C.EL	1000uF	6.3V
* C180	UU147100	C.EL	10uF	25V
* C181	UU137470	C.EL	47uF	16V
* C182	UU137470	C.EL	47uF	16V
* C183	UU137470	C.EL	47uF	16V
* C184	UU137470	C.EL	47uF	16V
* C185	UU147100	C.EL	10uF	25V
C186	UP652100	C.POL	100pF	100V
C188	UP652100	C.POL	100pF	100V
C190	UB013100	C.CE.M.CHP	1000pF	50V
C191	UB013100	C.CE.M.CHP	1000pF	50V
* C192	UU118100	C.EL	100uF	6.3V
C193	UB245100	C.CE.M.CHP	0.1uF	25V
* C194	UU147100	C.EL	10uF	25V
* C195	UU147100	C.EL	10uF	25V
C196	UP652100	C.POL	100pF	100V
C198	UB245100	C.CE.M.CHP	0.1uF	25V
C199	UB245100	C.CE.M.CHP	0.1uF	25V
C200	UB245100	C.CE.M.CHP	0.1uF	25V
C201	UB245100	C.CE.M.CHP	0.1uF	25V
* C202	UU138100	C.EL	100uF	16V
C203	UP652100	C.POL	100pF	100V
* C204	UU166220	C.EL	2.2uF	50V
* C205	UU166220	C.EL	2.2uF	50V
* C206	UU166220	C.EL	2.2uF	50V

* New Parts

P.C.B. FUNCTION

Schm Ref.	PART NO.	Description		
* C207	UU166220	C.EL	2.2uF	50V
* C208	UU166220	C.EL	2.2uF	50V
* C211	UU119100	C.EL	1000uF	6.3V
C212	UB245100	C.CE.M.CHP	0.1uF	25V
C213	UB245100	C.CE.M.CHP	0.1uF	25V
C214	UB245100	C.CE.M.CHP	0.1uF	25V
C215	UB013100	C.CE.M.CHP	1000pF	50V
C216	UB013100	C.CE.M.CHP	1000pF	50V
* C217	UU137220	C.EL	22uF	16V
* C218	UU137220	C.EL	22uF	16V
C219	UB245100	C.CE.M.CHP	0.1uF	25V
C220	UB245100	C.CE.M.CHP	0.1uF	25V
C221	UB245100	C.CE.M.CHP	0.1uF	25V
C222	UB245100	C.CE.M.CHP	0.1uF	25V
C223	UB245100	C.CE.M.CHP	0.1uF	25V
C244	UB245100	C.CE.M.CHP	0.1uF	25V
* C245	UU166100	C.EL	1uF	50V
C246	UB245100	C.CE.M.CHP	0.1uF	25V
C247	UB245100	C.CE.M.CHP	0.1uF	25V
* C248	UU147100	C.EL	10uF	25V
* C249	UU147100	C.EL	10uF	25V
* C250	UU147100	C.EL	10uF	25V
* C251	UU147100	C.EL	10uF	25V
* C252	UU147100	C.EL	10uF	25V
* C253	UU147100	C.EL	10uF	25V
C351	UB245100	C.CE.M.CHP	0.1uF	25V
* C353	UU118100	C.EL	100uF	6.3V
C354	UB245100	C.CE.M.CHP	0.1uF	25V
D3	VG437400	DIODE.ZENR	MTZJ5.1B	5.1V
D4	VT332900	DIODE	1SS355	
D5	VG437700	DIODE.ZENR	MTZJ5.6B	5.6V
D6	VG437700	DIODE.ZENR	MTZJ5.6B	5.6V
D7	VG437300	DIODE.ZENR	MTZJ5.1A	5.1V
D8	VG437300	DIODE.ZENR	MTZJ5.1A	5.1V
D9	iF004600	DIODE	1SS133	
D10	VG438100	DIODE.ZENR	MTZJ6.2C	6.2V(RT)
D10	VG438200	DIODE.ZENR	MTZJ6.8A6.8V	(UCABG)
D11	VT332900	DIODE	1SS355	
D12	iF004600	DIODE	1SS133	
D13	iF004600	DIODE	1SS133	
D16	iF004600	DIODE	1SS133	
D17	iF004600	DIODE	1SS133	
D18	VT332900	DIODE	1SS355	
D19	VT332900	DIODE	1SS355	
D20	VT332900	DIODE	1SS355	
D21	VT332900	DIODE	1SS355	
D22	VT332900	DIODE	1SS355	
D351	iF004600	DIODE	1SS133	
* D352	V2598200	LED	SIR-505ST	
D353	iF004600	DIODE	1SS133	
IC1	XJ553A00	IC	NJM2068MD	
* IC2	XW192A00	IC	TC9274N-XXX	
* IC3	XW192A00	IC	TC9274N-XXX	

* New Parts

Schm Ref.	PART NO.	Description		
IC4	XF291A00	IC		uPC4570G2
IC5	XF291A00	IC		uPC4570G2
IC6	XF291A00	IC		uPC4570G2
IC7	XF291A00	IC		uPC4570G2
IC8	XF291A00	IC		uPC4570G2
IC9	XS884A00	IC		LC7536Y
IC10	XF291A00	IC		uPC4570G2
IC11	XP894A00	IC		LC78211
IC12	XF291A00	IC		uPC4570G2
IC13	XF291A00	IC		uPC4570G2
IC14	XF291A00	IC		uPC4570G2
IC15	XF291A00	IC		uPC4570G2
* IC16	XW173A00	IC		CS3310-KS
* IC17	XW173A00	IC		CS3310-KS
* IC18	XW173A00	IC		CS3310-KS
* IC19	XW173A00	IC		CS3310-KS
* IC20	XW173A00	IC		CS3310-KS
IC21	XP895A00	IC		LC78212
IC22	XF291A00	IC		uPC4570G2
IC23	XF291A00	IC		uPC4570G2
IC24	XF291A00	IC		uPC4570G2
IC25	XF291A00	IC		uPC4570G2
IC26	XF291A00	IC		uPC4570G2
* IC27	XW729A00	IC		CPU,EPROM
IC28	XA507A00	IC		AN78N05
* IC31	XW863A00	IC		ADM202JRN-REEL7
JK351	VJ726800	JACK.MNI		
JK352	VJ726800	JACK.MNI		
JK353	VJ726800	JACK.MNI		
JK354	VJ726800	JACK.MNI		
* PJ1	V4805800	JACK.PIN		4P
* PJ2	V4807000	JACK.PIN		4P(UCA)
* PJ2	V4807100	JACK.PIN		6P(RTBG)
* PJ3	V4807000	JACK.PIN		4P
* PJ4	V4807000	JACK.PIN		4P
* PJ5	V4806600	JACK.PIN		2P
* PJ6	V4806500	JACK.PIN		2P
Q1	VD303700	TR		2SC3326 A,B
Q2	VD303700	TR		2SC3326 A,B
Q3	iA103700	TR.CHP		2SA1037 Q,R,S
Q4	iA103700	TR.CHP		2SA1037 Q,R,S
Q5	iA103700	TR.CHP		2SA1037 Q,R,S
Q6	iA103700	TR.CHP		2SA1037 Q,R,S
Q7	iA103700	TR.CHP		2SA1037 Q,R,S
Q8	VV655700	TR.DGT		DTC144EKA
Q9	iA103700	TR.CHP		2SA1037 Q,R,S
Q10	iA103700	TR.CHP		2SA1037 Q,R,S
Q11	iA103700	TR.CHP		2SA1037 Q,R,S
Q12	iA103700	TR.CHP		2SA1037 Q,R,S
Q13	iA103700	TR.CHP		2SA1037 Q,R,S
Q14	iA103700	TR.CHP		2SA1037 Q,R,S
Q15	iA103700	TR.CHP		2SA1037 Q,R,S
Q16	iA103700	TR.CHP		2SA1037 Q,R,S

* New Parts

P.C.B. FUNCTION

Schm Ref.	PART NO.	Description
Q17	iA103700	TR.CHP 2SA1037 Q,R,S
Q18	iA103700	TR.CHP 2SA1037 Q,R,S
Q19	VD303700	TR 2SC3326 A,B
Q20	VP872700	TR 2SC4488 S,T
Q21	VP872600	TR 2SA1708 S,T
Q22	VV655700	TR.DGT DTC144EKA
Q23	VV655300	TR.DGT DTA144EKA
Q24	VD303700	TR 2SC3326 A,B
Q25	VD303700	TR 2SC3326 A,B
Q26	VV556400	TR 2SC2412K Q,R,S
R5	Vi199600	R.MTL.CHP 82KΩ 1/10W
R7	VK581200	R.MTL.CHP 120KΩ 1/10W
R8	VK581200	R.MTL.CHP 120KΩ 1/10W
R10	Vi199600	R.MTL.CHP 82KΩ 1/10W
R14	Vi199200	R.MTL.CHP 56KΩ 1/10W
R15	Vi199200	R.MTL.CHP 56KΩ 1/10W
R18	Vi199200	R.MTL.CHP 56KΩ 1/10W(RTBG)
R19	Vi199200	R.MTL.CHP 56KΩ 1/10W(RTBG)
R22	Vi199200	R.MTL.CHP 56KΩ 1/10W
R23	Vi199200	R.MTL.CHP 56KΩ 1/10W
R28	Vi199200	R.MTL.CHP 56KΩ 1/10W
R29	Vi199200	R.MTL.CHP 56KΩ 1/10W
R34	Vi199200	R.MTL.CHP 56KΩ 1/10W
R35	VK582200	R.MTL.CHP 330KΩ 1/10W
R36	VK582200	R.MTL.CHP 330KΩ 1/10W
R37	Vi199200	R.MTL.CHP 56KΩ 1/10W
R40	Vi199200	R.MTL.CHP 56KΩ 1/10W
R41	VK582200	R.MTL.CHP 330KΩ 1/10W
R42	VK582200	R.MTL.CHP 330KΩ 1/10W
R43	Vi199200	R.MTL.CHP 56KΩ 1/10W
R46	Vi199200	R.MTL.CHP 56KΩ 1/10W
R47	VK582200	R.MTL.CHP 330KΩ 1/10W
R48	Vi199200	R.MTL.CHP 56KΩ 1/10W
R49	VK582200	R.MTL.CHP 330KΩ 1/10W
R52	Vi200000	R.MTL.CHP 100KΩ 1/10W
R53	Vi200000	R.MTL.CHP 100KΩ 1/10W
R55	Vi192500	R.MTL.CHP 100Ω 1/10W
R56	Vi199600	R.MTL.CHP 82KΩ 1/10W
R57	Vi197000	R.MTL.CHP 6.8KΩ 1/10W
R58	Vi199000	R.MTL.CHP 47KΩ 1/10W
R59	Vi192900	R.MTL.CHP 150Ω 1/10W
R60	Vi192900	R.MTL.CHP 150Ω 1/10W
R61	Vi199000	R.MTL.CHP 47KΩ 1/10W
R62	Vi192500	R.MTL.CHP 100Ω 1/10W
R63	Vi199600	R.MTL.CHP 82KΩ 1/10W
R64	Vi197000	R.MTL.CHP 6.8KΩ 1/10W
R65	VK583400	R.MTL.CHP 1MΩ 1/10W
R66	VK583400	R.MTL.CHP 1MΩ 1/10W
R67	VK583400	R.MTL.CHP 1MΩ 1/10W
R68	VK583400	R.MTL.CHP 1MΩ 1/10W
R69	Vi200000	R.MTL.CHP 100KΩ 1/10W
R70	Vi200000	R.MTL.CHP 100KΩ 1/10W
R71	Vi197400	R.MTL.CHP 10KΩ 1/10W

* New Parts

Schm Ref.	PART NO.	Description
R72	Vi196600	R.MTL.CHP 4.7KΩ 1/10W
R73	Vi200000	R.MTL.CHP 100KΩ 1/10W
R74	Vi196100	R.MTL.CHP 3.3KΩ 1/10W
R75	Vi197200	R.MTL.CHP 8.2KΩ 1/10W
R76	Vi197200	R.MTL.CHP 8.2KΩ 1/10W
R77	Vi196100	R.MTL.CHP 3.3KΩ 1/10W
R78	Vi194900	R.MTL.CHP 1KΩ 1/10W
R79	Vi197000	R.MTL.CHP 6.8KΩ 1/10W
R80	Vi196100	R.MTL.CHP 3.3KΩ 1/10W
R81	Vi198600	R.MTL.CHP 33KΩ 1/10W
R82	Vi198600	R.MTL.CHP 33KΩ 1/10W
R83	Vi196100	R.MTL.CHP 3.3KΩ 1/10W
R84	Vi197000	R.MTL.CHP 6.8KΩ 1/10W
R85	Vi194900	R.MTL.CHP 1KΩ 1/10W
R86	HV455100	R.CAR.FP 100Ω 1/4W
R87	Vi192500	R.MTL.CHP 100Ω 1/10W
R88	Vi192500	R.MTL.CHP 100Ω 1/10W
R89	HV455100	R.CAR.FP 100Ω 1/4W
R90	VK583400	R.MTL.CHP 1MΩ 1/10W
R91	VK583400	R.MTL.CHP 1MΩ 1/10W
R92	VK583400	R.MTL.CHP 1MΩ 1/10W
R93	VK583400	R.MTL.CHP 1MΩ 1/10W
R94	Vi197400	R.MTL.CHP 10KΩ 1/10W
R95	Vi196600	R.MTL.CHP 4.7KΩ 1/10W
R96	Vi195700	R.MTL.CHP 2.2KΩ 1/10W
R97	Vi195100	R.MTL.CHP 1.2KΩ 1/10W
R98	VK583400	R.MTL.CHP 1MΩ 1/10W
R99	VK583400	R.MTL.CHP 1MΩ 1/10W
R100	Vi195100	R.MTL.CHP 1.2KΩ 1/10W
R101	Vi200000	R.MTL.CHP 100KΩ 1/10W
R102	Vi200000	R.MTL.CHP 100KΩ 1/10W
R103	Vi199000	R.MTL.CHP 47KΩ 1/10W
R104	Vi197400	R.MTL.CHP 10KΩ 1/10W
R105	Vi197400	R.MTL.CHP 10KΩ 1/10W
R106	Vi199000	R.MTL.CHP 47KΩ 1/10W
R107	VK583400	R.MTL.CHP 1MΩ 1/10W
R108	VK583400	R.MTL.CHP 1MΩ 1/10W
R109	VK583400	R.MTL.CHP 1MΩ 1/10W
R110	VK583400	R.MTL.CHP 1MΩ 1/10W
R111	Vi200000	R.MTL.CHP 100KΩ 1/10W
R112	Vi200000	R.MTL.CHP 100KΩ 1/10W
R113	Vi200000	R.MTL.CHP 100KΩ 1/10W
R114	Vi200000	R.MTL.CHP 100KΩ 1/10W
R115	Vi200000	R.MTL.CHP 100KΩ 1/10W
R116	Vi200000	R.MTL.CHP 100KΩ 1/10W
R117	Vi200000	R.MTL.CHP 100KΩ 1/10W
R118	Vi191700	R.MTL.CHP 47Ω 1/10W(UCA)
R119	Vi191700	R.MTL.CHP 47Ω 1/10W(UCA)
R120	Vi191700	R.MTL.CHP 47Ω 1/10W(UCA)
R121	Vi192500	R.MTL.CHP 100Ω 1/10W
R122	Vi192500	R.MTL.CHP 100Ω 1/10W
R123	Vi192500	R.MTL.CHP 100Ω 1/10W
R124	Vi192500	R.MTL.CHP 100Ω 1/10W

* New Parts

P.C.B. FUNCTION

Schm Ref.	PART NO.	Description		
R125	Vi192500	R.MTL.CHP	100Ω	1/10W
R126	HV453220	R.CAR.FP	2.2Ω	1/4W
R127	Vi199000	R.MTL.CHP	47KΩ	1/10W
R128	Vi200000	R.MTL.CHP	100KΩ	1/10W
R129	Vi200000	R.MTL.CHP	100KΩ	1/10W
R130	Vi199000	R.MTL.CHP	47KΩ	1/10W
R131	Vi200000	R.MTL.CHP	100KΩ	1/10W
R132	Vi200000	R.MTL.CHP	100KΩ	1/10W
R133	Vi200000	R.MTL.CHP	100KΩ	1/10W
R134	Vi200000	R.MTL.CHP	100KΩ	1/10W
R135	Vi200000	R.MTL.CHP	100KΩ	1/10W
R136	Vi197400	R.MTL.CHP	10KΩ	1/10W
R137	Vi200000	R.MTL.CHP	100KΩ	1/10W
R138	Vi192500	R.MTL.CHP	100Ω	1/10W
R139	Vi200000	R.MTL.CHP	100KΩ	1/10W
R140	Vi197400	R.MTL.CHP	10KΩ	1/10W
R141	Vi200000	R.MTL.CHP	100KΩ	1/10W
R142	Vi192500	R.MTL.CHP	100Ω	1/10W
R143	Vi200000	R.MTL.CHP	100KΩ	1/10W
R144	Vi191700	R.MTL.CHP	47Ω	1/10W(UCA)
R145	Vi191700	R.MTL.CHP	47Ω	1/10W(UCA)
R147	Vi198200	R.MTL.CHP	22KΩ	1/10W
R148	Vi191700	R.MTL.CHP	47Ω	1/10W(UCA)
R149	Vi191700	R.MTL.CHP	47Ω	1/10W(UCA)
R150	Vi198200	R.MTL.CHP	22KΩ	1/10W
R152	Vi192500	R.MTL.CHP	100Ω	1/10W
R153	Vi195300	R.MTL.CHP	1.5KΩ	1/10W
R154	HV453220	R.CAR.FP	2.2Ω	1/4W
R155	HV454100	R.CAR.FP	10Ω	1/4W
R156	Vi199000	R.MTL.CHP	47KΩ	1/10W
R157	Vi199000	R.MTL.CHP	47KΩ	1/10W
R158	Vi199000	R.MTL.CHP	47KΩ	1/10W
R159	Vi199000	R.MTL.CHP	47KΩ	1/10W
R160	Vi199000	R.MTL.CHP	47KΩ	1/10W
R161	Vi197400	R.MTL.CHP	10KΩ	1/10W
R163	Vi197400	R.MTL.CHP	10KΩ	1/10W
R164	Vi192500	R.MTL.CHP	100Ω	1/10W
R165	Vi194100	R.MTL.CHP	470Ω	1/10W
R166	Vi200000	R.MTL.CHP	100KΩ	1/10W
R167	Vi195300	R.MTL.CHP	1.5KΩ	1/10W
R169	Vi197400	R.MTL.CHP	10KΩ	1/10W
R170	Vi197400	R.MTL.CHP	10KΩ	1/10W
R171	Vi200000	R.MTL.CHP	100KΩ	1/10W
R172	Vi197400	R.MTL.CHP	10KΩ	1/10W
R173	Vi197800	R.MTL.CHP	15KΩ	1/10W
R174	Vi200000	R.MTL.CHP	100KΩ	1/10W
R175	Vi196800	R.MTL.CHP	5.6KΩ	1/10W
R176	Vi196800	R.MTL.CHP	5.6KΩ	1/10W
R177	Vi194900	R.MTL.CHP	1KΩ	1/10W
R178	Vi195900	R.MTL.CHP	2.7KΩ	1/10W
R179	Vi196600	R.MTL.CHP	4.7KΩ	1/10W
R180	Vi192500	R.MTL.CHP	100Ω	1/10W
R181	VK583400	R.MTL.CHP	1MΩ	1/10W

* New Parts

Schm Ref.	PART NO.	Description		
R182	Vi196100	R.MTL.CHP	3.3KΩ	1/10W
R183	VK583400	R.MTL.CHP	1MΩ	1/10W
R184	Vi196100	R.MTL.CHP	3.3KΩ	1/10W
R185	Vi192500	R.MTL.CHP	100Ω	1/10W
R186	Vi196600	R.MTL.CHP	4.7KΩ	1/10W
R187	Vi196600	R.MTL.CHP	4.7KΩ	1/10W
R188	Vi196100	R.MTL.CHP	3.3KΩ	1/10W
R189	Vi199000	R.MTL.CHP	47KΩ	1/10W
R190	Vi199000	R.MTL.CHP	47KΩ	1/10W
R191	Vi199000	R.MTL.CHP	47KΩ	1/10W
R192	Vi199000	R.MTL.CHP	47KΩ	1/10W
R193	Vi199000	R.MTL.CHP	47KΩ	1/10W
R194	Vi199000	R.MTL.CHP	47KΩ	1/10W
R195	Vi196100	R.MTL.CHP	3.3KΩ	1/10W
R196	Vi196600	R.MTL.CHP	4.7KΩ	1/10W
R197	Vi196600	R.MTL.CHP	4.7KΩ	1/10W
R198	Vi192500	R.MTL.CHP	100Ω	1/10W
R199	Vi196100	R.MTL.CHP	3.3KΩ	1/10W
R200	Vi196100	R.MTL.CHP	3.3KΩ	1/10W
R201	Vi196100	R.MTL.CHP	3.3KΩ	1/10W
R202	Vi196100	R.MTL.CHP	3.3KΩ	1/10W
R203	Vi192500	R.MTL.CHP	100Ω	1/10W
R204	Vi197400	R.MTL.CHP	10KΩ	1/10W
R205	Vi197400	R.MTL.CHP	10KΩ	1/10W
R206	Vi196700	R.MTL.CHP	5.1KΩ	1/10W
R207	Vi200000	R.MTL.CHP	100KΩ	1/10W
R208	Vi196100	R.MTL.CHP	3.3KΩ	1/10W
R209	Vi197400	R.MTL.CHP	10KΩ	1/10W
R210	Vi199000	R.MTL.CHP	47KΩ	1/10W
R211	Vi197200	R.MTL.CHP	8.2KΩ	1/10W
R212	Vi197200	R.MTL.CHP	8.2KΩ	1/10W
R213	Vi199000	R.MTL.CHP	47KΩ	1/10W
R214	Vi197400	R.MTL.CHP	10KΩ	1/10W
R215	Vi196100	R.MTL.CHP	3.3KΩ	1/10W
R216	Vi197400	R.MTL.CHP	10KΩ	1/10W
R219	Vi197400	R.MTL.CHP	10KΩ	1/10W
R220	Vi192500	R.MTL.CHP	100Ω	1/10W(A)
R221	Vi192500	R.MTL.CHP	100Ω	1/10W(UC)
R222	Vi192500	R.MTL.CHP	100Ω	1/10W(UCA)
R224	Vi199000	R.MTL.CHP	47KΩ	1/10W(UC)
R225	Vi195900	R.MTL.CHP	2.7KΩ	1/10W
R226	Vi192100	R.MTL.CHP	68Ω	1/10W
R227	Vi192500	R.MTL.CHP	100Ω	1/10W
R228	Vi197200	R.MTL.CHP	8.2KΩ	1/10W
R229	Vi196100	R.MTL.CHP	3.3KΩ	1/10W
R230	Vi196100	R.MTL.CHP	3.3KΩ	1/10W
R231	Vi197200	R.MTL.CHP	8.2KΩ	1/10W
R232	Vi192500	R.MTL.CHP	100Ω	1/10W
R233	Vi199000	R.MTL.CHP	47KΩ	1/10W(RTABG)
R234	Vi199000	R.MTL.CHP	47KΩ	1/10W
R235	Vi199000	R.MTL.CHP	47KΩ	1/10W
R236	Vi200000	R.MTL.CHP	100KΩ	1/100W(RTBG)
R237	Vi200000	R.MTL.CHP	100KΩ	1/100W(RTBG)

* New Parts

P.C.B. FUNCTION

Schm Ref.	PART NO.	Description
R240	Vi191700	R.MTL.CHP 47Ω 1/10W
R241	Vi191700	R.MTL.CHP 47Ω 1/10W
R242	Vi200000	R.MTL.CHP 100KΩ 1/10W
R243	Vi200000	R.MTL.CHP 100KΩ 1/10W
R244	Vi200000	R.MTL.CHP 100KΩ 1/10W
R245	Vi200000	R.MTL.CHP 100KΩ 1/10W
R246	Vi196100	R.MTL.CHP 3.3KΩ 1/10W
R247	Vi196100	R.MTL.CHP 3.3KΩ 1/10W
R248	Vi196100	R.MTL.CHP 3.3KΩ 1/10W
R249	Vi196100	R.MTL.CHP 3.3KΩ 1/10W
R250	Vi197400	R.MTL.CHP 10KΩ 1/10W
R251	Vi200000	R.MTL.CHP 100KΩ 1/10W
R252	Vi197400	R.MTL.CHP 10KΩ 1/10W
R253	Vi200000	R.MTL.CHP 100KΩ 1/10W
R254	Vi197400	R.MTL.CHP 10KΩ 1/10W
R255	Vi200000	R.MTL.CHP 100KΩ 1/10W
R256	Vi197400	R.MTL.CHP 10KΩ 1/10W
R257	Vi200000	R.MTL.CHP 100KΩ 1/10W
R258	Vi197400	R.MTL.CHP 10KΩ 1/10W
R259	Vi200000	R.MTL.CHP 100KΩ 1/10W
R261	HV454100	R.CAR.FP 10Ω 1/4W
R262	Vi196100	R.MTL.CHP 3.3KΩ 1/10W
R263	HV453220	R.CAR.FP 2.2Ω 1/4W
R264	HV453220	R.CAR.FP 2.2Ω 1/4W
R265	Vi199600	R.MTL.CHP 82KΩ 1/10W
R266	Vi192500	R.MTL.CHP 100Ω 1/10W
R267	Vi199600	R.MTL.CHP 82KΩ 1/10W
R268	Vi192500	R.MTL.CHP 100Ω 1/10W
R269	Vi199600	R.MTL.CHP 82KΩ 1/10W
R270	Vi192500	R.MTL.CHP 100Ω 1/10W
R271	Vi199600	R.MTL.CHP 82KΩ 1/10W
R272	Vi192500	R.MTL.CHP 100Ω 1/10W
R273	Vi199600	R.MTL.CHP 82KΩ 1/10W
R274	Vi192500	R.MTL.CHP 100Ω 1/10W
R277	Vi192500	R.MTL.CHP 100Ω 1/10W
R278	Vi192500	R.MTL.CHP 100Ω 1/10W
R279	Vi192500	R.MTL.CHP 100Ω 1/10W
R280	Vi192500	R.MTL.CHP 100Ω 1/10W
R281	Vi192500	R.MTL.CHP 100Ω 1/10W
R282	Vi192500	R.MTL.CHP 100Ω 1/10W
R283	Vi200000	R.MTL.CHP 100KΩ 1/10W
R284	Vi196600	R.MTL.CHP 4.7KΩ 1/10W
R285	Vi192500	R.MTL.CHP 100Ω 1/10W
R286	Vi192500	R.MTL.CHP 100Ω 1/10W
R287	Vi192500	R.MTL.CHP 100Ω 1/10W
R288	Vi192500	R.MTL.CHP 100Ω 1/10W
R289	Vi194100	R.MTL.CHP 470Ω 1/10W
R290	Vi194100	R.MTL.CHP 470Ω 1/10W
R291	Vi194100	R.MTL.CHP 470Ω 1/10W
R292	Vi191700	R.MTL.CHP 47Ω 1/10W
R296	Vi191700	R.MTL.CHP 47Ω 1/10W
R297	Vi191700	R.MTL.CHP 47Ω 1/10W
R299	Vi191700	R.MTL.CHP 47Ω 1/10W

* New Parts

Schm Ref.	PART NO.	Description
R300	Vi191700	R.MTL.CHP 47Ω 1/10W
R301	VK583400	R.MTL.CHP 1MΩ 1/10W
R302	VK583400	R.MTL.CHP 1MΩ 1/10W
R303	VK583400	R.MTL.CHP 1MΩ 1/10W
R304	VK583400	R.MTL.CHP 1MΩ 1/10W
R305	VK583400	R.MTL.CHP 1MΩ 1/10W
R307	Vi197400	R.MTL.CHP 10KΩ 1/10W
R311	Vi199000	R.MTL.CHP 47KΩ 1/10W
R312	Vi199000	R.MTL.CHP 47KΩ 1/10W
R313	HV453220	R.CAR.FP 2.2Ω 1/4W
R314	Vi197400	R.MTL.CHP 10KΩ 1/10W
R315	Vi200000	R.MTL.CHP 100KΩ 1/10W
R316	Vi200000	R.MTL.CHP 100KΩ 1/10W
R318	Vi195300	R.MTL.CHP 1.5KΩ 1/10W
R319	VK583400	R.MTL.CHP 1MΩ 1/10W
R321	Vi200000	R.MTL.CHP 100KΩ 1/10W
R322	Vi200000	R.MTL.CHP 100KΩ 1/10W
R323	Vi197400	R.MTL.CHP 10KΩ 1/10W
R324	Vi197400	R.MTL.CHP 10KΩ 1/10W
R325	Vi199000	R.MTL.CHP 47KΩ 1/10W(ABG)
R326	Vi199000	R.MTL.CHP 47KΩ 1/10W(UCRT)
R327	Vi200000	R.MTL.CHP 100KΩ 1/10W
R351	HL315100	R.MTL.OXD 100Ω 1W
R353	Vi191700	R.MTL.CHP 47Ω 1/10W
R356	Vi197400	R.MTL.CHP 10KΩ 1/10W
RY1	VM640200	RELAY RY12W-OH-K-DC12V
SW351	VT903900	SW.SLIDE SSAA22(RT)
U351	VU591000	L.DTCT GP1U271X
* XL1	V4738900	RSNR.CE 12MHz
	V3750100	PIN L=50
	BB071360	SCR.TERM 8.3x13

* New Parts

P.C.B. DSP

Schm Ref.	PART NO.	Description
*	V5003000	P.C.B. DSP(RBGT)
*	V5003100	P.C.B. DSP(UA)
*	V5003200	P.C.B. DSP(C)
*	CB1	V4707900 CN.FBRSNSR 1P GP1F37R1
*	CB2	V4707900 CN.FBRSNSR 1P GP1F37R1
*	CB3	V4707800 CN.FBRLINK 1P GP1F38T2
*	CB4	V4707900 CN.FBRSNSR 1P GP1F37R1
*	CB5	V4707900 CN.FBRSNSR 1P GP1F37R1
*	CB6	V4707900 CN.FBRSNSR 1P GP1F37R1
*	CB7	V4707900 CN.FBRSNSR 1P GP1F37R1
*	CB8	V4707900 CN.FBRSNSR 1P GP1F37R1
	CB11	VP682300 CN.BS.PIN 8P
	CB12	VP682300 CN.BS.PIN 8P
	CB13	LB919040 CN.BS.PIN 4P
	CB14	VQ044700 CN.BS.PIN 16P
	CB15	LB919020 CN.BS.PIN 2P
	CB801	LA002000 TERM.WRAP 2P(C)
	CB802	LA002000 TERM.WRAP 2P(C)
	CB901	VB858200 CN.BS.PIN 3P
	CB902	VQ044700 CN.BS.PIN 16P
	CB941	VQ963700 CN.BS.PIN 16P(UAC)
	CB942	VM923600 CN.BS.PIN 13P(UAC)
	C1	UB245100 C.CE.M.CHP 0.1uF 25V
	C2	UB245100 C.CE.M.CHP 0.1uF 25V
	C3	UB245100 C.CE.M.CHP 0.1uF 25V
	C4	UB245100 C.CE.M.CHP 0.1uF 25V
	C5	UB245100 C.CE.M.CHP 0.1uF 25V
	C6	UB245100 C.CE.M.CHP 0.1uF 25V
	C7	UB245100 C.CE.M.CHP 0.1uF 25V
	C8	UB245100 C.CE.M.CHP 0.1uF 25V
	C9	UB051100 C.CE.M.CHP 10pF 50V
	C10	UB044220 C.CE.M.CHP 0.022uF 50V
	C11	UB044220 C.CE.M.CHP 0.022uF 50V
	C12	UB245100 C.CE.M.CHP 0.1uF 25V
*	C13	UU147220 C.EL 22uF 25V
	C14	UB051220 C.CE.M.CHP 22pF 50V
	C15	UB245100 C.CE.M.CHP 0.1uF 25V
*	C16	UU147220 C.EL 22uF 25V
	C17	UB051220 C.CE.M.CHP 22pF 50V
	C18	UB245100 C.CE.M.CHP 0.1uF 25V
*	C19	UU147220 C.EL 22uF 25V
	C20	UB051220 C.CE.M.CHP 22pF 50V
	C21	UB245100 C.CE.M.CHP 0.1uF 25V
	C22	UB044220 C.CE.M.CHP 0.022uF 50V
	C23	VJ901600 C.CE.M.CHP 75pF 50V
	C24	UB012220 C.CE.M.CHP 220pF 50V
	C25	UB051100 C.CE.M.CHP 10pF 50V
*	C26	UU137470 C.EL 47uF 16V
	C27	UB245100 C.CE.M.CHP 0.1uF 25V
	C28	UB012220 C.CE.M.CHP 220pF 50V
	C29	UB051100 C.CE.M.CHP 10pF 50V
	C30	UB012220 C.CE.M.CHP 220pF 50V
	C31	UB051100 C.CE.M.CHP 10pF 50V

* New Parts

Schm Ref.	PART NO.	Description
	C32	UB044220 C.CE.M.CHP 0.022uF 50V
	C33	UB245100 C.CE.M.CHP 0.1uF 25V
	C34	UB051100 C.CE.M.CHP 10pF 50V
	C35	UB245100 C.CE.M.CHP 0.1uF 25V
	C36	UB013100 C.CE.M.CHP 1000pF 50V
*	C37	UU137470 C.EL 47uF 16V
*	C38	UU137470 C.EL 47uF 16V
*	C39	V3888000 C.MYLAR 150pF 50V
*	C40	UU147100 C.EL 10uF 25V
	C41	UB245100 C.CE.M.CHP 0.1uF 25V
*	C42	UU147100 C.EL 10uF 25V
	C43	UB245100 C.CE.M.CHP 0.1uF 25V
*	C44	V3888000 C.MYLAR 150pF 50V
*	C45	UU137470 C.EL 47uF 16V
*	C46	UU137470 C.EL 47uF 16V
*	C47	UU137470 C.EL 47uF 16V
	C48	UB245100 C.CE.M.CHP 0.1uF 25V
*	C49	UU137470 C.EL 47uF 16V
	C50	UB245100 C.CE.M.CHP 0.1uF 25V
	C51	UB013100 C.CE.M.CHP 1000pF 50V
	C52	UB013100 C.CE.M.CHP 1000pF 50V
	C53	UB013100 C.CE.M.CHP 1000pF 50V
	C54	UB245100 C.CE.M.CHP 0.1uF 25V
	C55	UB051100 C.CE.M.CHP 10pF 50V
	C56	UB245100 C.CE.M.CHP 0.1uF 25V
*	C57	VJ900600 C.CE.M.CHP 30pF 50V
	C58	UB013100 C.CE.M.CHP 1000pF 50V
*	C59	VJ900600 C.CE.M.CHP 30pF 50V
	C60	UB044220 C.CE.M.CHP 0.022uF 50V
*	C61	V3888000 C.MYLAR 150pF 50V
	C62	UA654220 C.MYLAR 0.022uF 50V
*	C63	UU147100 C.EL 10uF 25V
	C64	UB245100 C.CE.M.CHP 0.1uF 25V
	C65	UB245100 C.CE.M.CHP 0.1uF 25V
*	C66	UU147100 C.EL 10uF 25V
	C67	UA654220 C.MYLAR 0.022uF 50V
*	C68	V3888000 C.MYLAR 150pF 50V
	C69	UB051100 C.CE.M.CHP 10pF 50V
	C70	UB044100 C.CE.M.CHP 0.01uF 50V
	C71	UB245100 C.CE.M.CHP 0.1uF 25V
*	C72	UU147100 C.EL 10uF 25V
	C73	UB245100 C.CE.M.CHP 0.1uF 25V
	C74	UA653470 C.MYLAR 4700pF 50V
	C75	UB245100 C.CE.M.CHP 0.1uF 25V
*	C76	UU147100 C.EL 10uF 25V
	C77	UB245220 C.CE.M.CHP 0.22uF 25V
	C78	UB245220 C.CE.M.CHP 0.22uF 25V
*	C79	UU147100 C.EL 10uF 25V
	C80	UB245100 C.CE.M.CHP 0.1uF 25V
	C81	VR169200 C.MYLAR.ML ECQ-V1H474JL3
	C82	VR169200 C.MYLAR.ML ECQ-V1H474JL3
	C83	UB245100 C.CE.M.CHP 0.1uF 25V
	C84	UB245100 C.CE.M.CHP 0.1uF 25V

* New Parts

P.C.B. DSP

Schm Ref.	PART NO.	Description		
C85	VJ900700	C.CE.M.CHP	33pF	50V
C86	VJ900700	C.CE.M.CHP	33pF	50V
C87	UB245100	C.CE.M.CHP	0.1uF	25V
* C88	UU128100	C.EL	100uF	10V
* C89	UU128100	C.EL	100uF	10V
C90	UB245100	C.CE.M.CHP	0.1uF	25V
C91	UB245100	C.CE.M.CHP	0.1uF	25V
* C92	UU147100	C.EL	10uF	25V
C93	UB245100	C.CE.M.CHP	0.1uF	25V
* C94	UU128100	C.EL	100uF	10V
C95	UB245100	C.CE.M.CHP	0.1uF	25V
* C96	UU147100	C.EL	10uF	25V
C97	UB245100	C.CE.M.CHP	0.1uF	25V
* C98	UU128100	C.EL	100uF	10V
C99	UB245100	C.CE.M.CHP	0.1uF	25V
C100	UB245100	C.CE.M.CHP	0.1uF	25V
C101	UB245100	C.CE.M.CHP	0.1uF	25V
C102	UB245100	C.CE.M.CHP	0.1uF	25V
* C103	UU128100	C.EL	100uF	10V
C104	UB245100	C.CE.M.CHP	0.1uF	25V
C105	UB245100	C.CE.M.CHP	0.1uF	25V
C107	UN837470	C.EL	47uF	16V
* C108	UU128100	C.EL	100uF	10V
C109	UB245100	C.CE.M.CHP	0.1uF	25V
C110	UB245100	C.CE.M.CHP	0.1uF	25V
C111	UB245100	C.CE.M.CHP	0.1uF	25V
C112	UB245100	C.CE.M.CHP	0.1uF	25V
C113	VJ900100	C.CE.M.CHP	18pF	50V
C114	VJ898700	C.CE.M.CHP	2pF	50V
* C118	UU128100	C.EL	100uF	10V
C119	UB044100	C.CE.M.CHP	0.01uF	50V
C120	UB044100	C.CE.M.CHP	0.01uF	50V
C121	UB245100	C.CE.M.CHP	0.1uF	25V
* C122	UU128100	C.EL	100uF	10V
C126	UB245100	C.CE.M.CHP	0.1uF	25V
C127	UB245100	C.CE.M.CHP	0.1uF	25V
* C128	UU128100	C.EL	100uF	10V
C129	UB245100	C.CE.M.CHP	0.1uF	25V
C139	UB245100	C.CE.M.CHP	0.1uF	25V
C140	UB012470	C.CE.M.CHP	470pF	50V
C141	UB245100	C.CE.M.CHP	0.1uF	25V
C146	UB245100	C.CE.M.CHP	0.1uF	25V
C149	UB245100	C.CE.M.CHP	0.1uF	25V
* C150	UU118330	C.EL	330uF	6.3V
C151	UB245100	C.CE.M.CHP	0.1uF	25V
C152	UB245100	C.CE.M.CHP	0.1uF	25V
C153	UB245100	C.CE.M.CHP	0.1uF	25V
C157	UB245100	C.CE.M.CHP	0.1uF	25V
C158	UB245100	C.CE.M.CHP	0.1uF	25V
* C159	UU128100	C.EL	100uF	10V
C160	UB245100	C.CE.M.CHP	0.1uF	25V
C161	UB245100	C.CE.M.CHP	0.1uF	25V
C162	UB245100	C.CE.M.CHP	0.1uF	25V

* New Parts

Schm Ref.	PART NO.	Description		
* C163	UU137470	C.EL	47uF	16V
* C164	UU137470	C.EL	47uF	16V
C165	VQ645600	C.MYLAR	100pF	50V
* C166	Vi716600	C.MYLAR	8200pF	50V
C167	UB012470	C.CE.M.CHP	470pF	50V
C168	UB245100	C.CE.M.CHP	0.1uF	25V
* C169	UU137470	C.EL	47uF	16V
C170	UB245100	C.CE.M.CHP	0.1uF	25V
C171	UB245100	C.CE.M.CHP	0.1uF	25V
C172	UB245100	C.CE.M.CHP	0.1uF	25V
* C173	UU128100	C.EL	100uF	10V
* C174	UU137220	C.EL	22uF	16V
* C175	UU128100	C.EL	100uF	10V
* C176	UU147100	C.EL	10uF	25V
C177	Vi716100	C.MYLAR	3300pF	50V
C178	Vi715100	C.MYLAR	470pF	50V
* C179	UU137470	C.EL	47uF	16V
* C180	UU137470	C.EL	47uF	16V
* C181	UU118330	C.EL	330uF	6.3V
* C182	UU147100	C.EL	10uF	25V
C183	UB245100	C.CE.M.CHP	0.1uF	25V
* C184	UU137470	C.EL	47uF	16V
C185	UB245100	C.CE.M.CHP	0.1uF	25V
C186	UB245100	C.CE.M.CHP	0.1uF	25V
C187	UB245100	C.CE.M.CHP	0.1uF	25V
* C188	UU137470	C.EL	47uF	16V
* C189	UU128100	C.EL	100uF	10V
* C190	UU137220	C.EL	22uF	16V
* C191	UU128100	C.EL	100uF	10V
C192	VQ645600	C.MYLAR	100pF	50V
* C193	UU147100	C.EL	10uF	25V
C194	Vi716100	C.MYLAR	3300pF	50V
C195	Vi715100	C.MYLAR	470pF	50V
* C196	Vi716600	C.MYLAR	8200pF	50V
* C197	UU128100	C.EL	100uF	10V
C198	UB245100	C.CE.M.CHP	0.1uF	25V
C199	UB245100	C.CE.M.CHP	0.1uF	25V
C200	UB245100	C.CE.M.CHP	0.1uF	25V
C201	UB245100	C.CE.M.CHP	0.1uF	25V
C202	UB245100	C.CE.M.CHP	0.1uF	25V
C203	UB245100	C.CE.M.CHP	0.1uF	25V
C204	UB245100	C.CE.M.CHP	0.1uF	25V
* C205	UU128100	C.EL	100uF	10V
C206	UB245100	C.CE.M.CHP	0.1uF	25V
C207	UB245100	C.CE.M.CHP	0.1uF	25V
* C208	UU137470	C.EL	47uF	16V
* C209	UU137470	C.EL	47uF	16V
C210	UB245100	C.CE.M.CHP	0.1uF	25V
* C211	UU137470	C.EL	47uF	16V
C212	VQ645600	C.MYLAR	100pF	50V
* C213	UU147100	C.EL	10uF	25V
* C214	Vi716500	C.MYLAR	6800pF	50V
* C215	Vi715500	C.MYLAR	1000pF	50V

* New Parts

P.C.B. DSP

Schm Ref.	PART NO.	Description		
* C216	Vi717000	C.MYLAR	0.018uF	50V
* C217	UU118330	C.EL	330uF	6.3V
C218	UB245100	C.CE.M.CHP	0.1uF	25V
C219	UB245100	C.CE.M.CHP	0.1uF	25V
C220	UB245100	C.CE.M.CHP	0.1uF	25V
* C221	UU137470	C.EL	47uF	16V
* C222	UU137470	C.EL	47uF	16V
C223	UB245100	C.CE.M.CHP	0.1uF	25V
C224	UB245100	C.CE.M.CHP	0.1uF	25V
C225	UB245100	C.CE.M.CHP	0.1uF	25V
* C226	UU128100	C.EL	100uF	10V
* C227	UU137220	C.EL	22uF	16V
* C228	UU137470	C.EL	47uF	16V
* C229	UU128100	C.EL	100uF	10V
* C230	UU128100	C.EL	100uF	10V
C231	VQ645600	C.MYLAR	100pF	50V
* C232	Vi716500	C.MYLAR	6800pF	50V
C233	Vi715500	C.MYLAR	1000pF	50V
* C234	UU137470	C.EL	47uF	16V
* C235	UU137470	C.EL	47uF	16V
* C236	UU128100	C.EL	100uF	10V
C237	UB245100	C.CE.M.CHP	0.1uF	25V
C238	UB245100	C.CE.M.CHP	0.1uF	25V
* C239	UU147100	C.EL	10uF	25V
C240	UB245100	C.CE.M.CHP	0.1uF	25V
* C241	UU137470	C.EL	47uF	16V
C242	UB245100	C.CE.M.CHP	0.1uF	25V
C243	UB245100	C.CE.M.CHP	0.1uF	25V
* C244	UU128100	C.EL	100uF	10V
* C245	UU137220	C.EL	22uF	16V
* C246	UU147100	C.EL	10uF	25V
* C247	Vi717000	C.MYLAR	0.018uF	50V
C248	UB245100	C.CE.M.CHP	0.1uF	25V
C249	UB245100	C.CE.M.CHP	0.1uF	25V
C250	UB245100	C.CE.M.CHP	0.1uF	25V
* C251	UU137470	C.EL	47uF	16V
C252	UB245100	C.CE.M.CHP	0.1uF	25V
C253	UB245100	C.CE.M.CHP	0.1uF	25V
* C254	UU137470	C.EL	47uF	16V
* C255	UU128100	C.EL	100uF	10V
* C256	UU137220	C.EL	22uF	16V
C257	VQ645600	C.MYLAR	100pF	50V
* C258	UU147100	C.EL	10uF	25V
* C259	Vi716500	C.MYLAR	6800pF	50V
C260	Vi715500	C.MYLAR	1000pF	50V
* C261	Vi717000	C.MYLAR	0.018uF	50V
* C262	UU137470	C.EL	47uF	16V
* C263	UU137470	C.EL	47uF	16V
* C264	UU137470	C.EL	47uF	16V
C265	UB245100	C.CE.M.CHP	0.1uF	25V
C266	UB245100	C.CE.M.CHP	0.1uF	25V
C267	UB245100	C.CE.M.CHP	0.1uF	25V
C268	UB245100	C.CE.M.CHP	0.1uF	25V

* New Parts

Schm Ref.	PART NO.	Description		
* C269	UU137470	C.EL	47uF	16V
* C270	UU128100	C.EL	100uF	10V
* C271	UU128100	C.EL	100uF	10V
* C272	UU128100	C.EL	100uF	10V
C273	VQ645600	C.MYLAR	100pF	50V
* C274	UU147100	C.EL	10uF	25V
* C275	Vi716500	C.MYLAR	6800pF	50V
C276	Vi715500	C.MYLAR	1000pF	50V
* C277	Vi717000	C.MYLAR	0.018uF	50V
* C278	UU137470	C.EL	47uF	16V
C279	UB245100	C.CE.M.CHP	0.1uF	25V
* C280	UU128100	C.EL	100uF	10V
C281	UB245100	C.CE.M.CHP	0.1uF	25V
C282	UB245100	C.CE.M.CHP	0.1uF	25V
C283	UB245100	C.CE.M.CHP	0.1uF	25V
* C284	UU118330	C.EL	330uF	6.3V
C285	UB245100	C.CE.M.CHP	0.1uF	25V
* C286	UU147100	C.EL	10uF	25V
C287	UB245100	C.CE.M.CHP	0.1uF	25V
* C288	UU137470	C.EL	47uF	16V
* C289	UU137470	C.EL	47uF	16V
* C290	UU137220	C.EL	22uF	16V
* C291	UU137470	C.EL	47uF	16V
C292	VQ645600	C.MYLAR	100pF	50V
* C293	Vi717000	C.MYLAR	0.018uF	50V
* C294	UU128100	C.EL	100uF	10V
C295	UB245100	C.CE.M.CHP	0.1uF	25V
* C296	UU118330	C.EL	330uF	6.3V
C297	UB245100	C.CE.M.CHP	0.1uF	25V
C298	UB245100	C.CE.M.CHP	0.1uF	25V
C299	UB245100	C.CE.M.CHP	0.1uF	25V
C300	UB245100	C.CE.M.CHP	0.1uF	25V
C302	UB245100	C.CE.M.CHP	0.1uF	25V
C303	UB245100	C.CE.M.CHP	0.1uF	25V
C304	UB245100	C.CE.M.CHP	0.1uF	25V
* C305	UU137470	C.EL	47uF	16V
* C306	UU137470	C.EL	47uF	16V
C307	UB245100	C.CE.M.CHP	0.1uF	25V
C308	UB245100	C.CE.M.CHP	0.1uF	25V
C309	UB245100	C.CE.M.CHP	0.1uF	25V
C310	UB245100	C.CE.M.CHP	0.1uF	25V
* C311	UU128100	C.EL	100uF	10V
* C312	UU137220	C.EL	22uF	16V
* C313	UU128100	C.EL	100uF	10V
* C314	UU128100	C.EL	100uF	10V
* C315	UU147100	C.EL	10uF	25V
* C316	Vi716500	C.MYLAR	6800pF	50V
C317	Vi715500	C.MYLAR	1000pF	50V
* C318	UU137470	C.EL	47uF	16V
* C319	UU137470	C.EL	47uF	16V
C320	UB245100	C.CE.M.CHP	0.1uF	25V
* C321	UU147100	C.EL	10uF	25V
C322	UB245100	C.CE.M.CHP	0.1uF	25V

* New Parts

P.C.B. DSP

Schm Ref.	PART NO.	Description		
* C323	UU137470	C.EL	47uF	16V
C324	UB245100	C.CE.M.CHP	0.1uF	25V
C325	UB245100	C.CE.M.CHP	0.1uF	25V
* C326	UU137470	C.EL	47uF	16V
* C327	UU128100	C.EL	100uF	10V
* C328	UU137220	C.EL	22uF	16V
C329	VQ645600	C.MYLAR	100pF	50V
* C330	UU147100	C.EL	10uF	25V
* C331	Vi716500	C.MYLAR	6800pF	50V
C332	Vi715500	C.MYLAR	1000pF	50V
* C333	Vi717000	C.MYLAR	0.018uF	50V
C334	UB245100	C.CE.M.CHP	0.1uF	25V
C335	UB245100	C.CE.M.CHP	0.1uF	25V
* C336	UU137470	C.EL	47uF	16V
C337	UB245100	C.CE.M.CHP	0.1uF	25V
C338	UB245100	C.CE.M.CHP	0.1uF	25V
* C339	UU137470	C.EL	47uF	16V
* C340	UU128100	C.EL	100uF	10V
C341	VQ645600	C.MYLAR	100pF	50V
* C342	UU147100	C.EL	10uF	25V
* C343	Vi716500	C.MYLAR	6800pF	50V
C344	Vi715500	C.MYLAR	1000pF	50V
* C345	Vi717000	C.MYLAR	0.018uF	50V
C346	UB245100	C.CE.M.CHP	0.1uF	25V
C347	UB245100	C.CE.M.CHP	0.1uF	25V
* C348	UU137470	C.EL	47uF	16V
* C349	UU137470	C.EL	47uF	16V
C350	UB245100	C.CE.M.CHP	0.1uF	25V
C351	UB245100	C.CE.M.CHP	0.1uF	25V
* C352	UU137220	C.EL	22uF	16V
* C353	UU137470	C.EL	47uF	16V
* C354	UU128100	C.EL	100uF	10V
* C355	UU128100	C.EL	100uF	10V
C356	VQ645600	C.MYLAR	100pF	50V
* C357	Vi716500	C.MYLAR	6800pF	50V
C358	Vi715500	C.MYLAR	1000pF	50V
* C359	UU137470	C.EL	47uF	16V
* C360	UU137470	C.EL	47uF	16V
C361	UB245100	C.CE.M.CHP	0.1uF	25V
* C362	UU128100	C.EL	100uF	10V
C363	UB245100	C.CE.M.CHP	0.1uF	25V
C364	UB245100	C.CE.M.CHP	0.1uF	25V
C365	UB245100	C.CE.M.CHP	0.1uF	25V
* C366	UU118330	C.EL	330uF	6.3V
C367	UB245100	C.CE.M.CHP	0.1uF	25V
* C368	UU147100	C.EL	10uF	25V
C369	UB245100	C.CE.M.CHP	0.1uF	25V
* C370	UU137470	C.EL	47uF	16V
C371	UB245100	C.CE.M.CHP	0.1uF	25V
C372	UB245100	C.CE.M.CHP	0.1uF	25V
* C373	UU128100	C.EL	100uF	10V
* C374	UU137220	C.EL	22uF	16V
* C375	UU147100	C.EL	10uF	25V

* New Parts

Schm Ref.	PART NO.	Description		
* C376	Vi717000	C.MYLAR	0.018uF	50V
C381	UB051470	C.CE.M.CHP	47pF	50V
C382	UB051470	C.CE.M.CHP	47pF	50V
C383	UB051470	C.CE.M.CHP	47pF	50V
C384	UB051470	C.CE.M.CHP	47pF	50V
C385	UB051470	C.CE.M.CHP	47pF	50V
C386	UB051470	C.CE.M.CHP	47pF	50V
C387	UB051470	C.CE.M.CHP	47pF	50V
C388	UB051470	C.CE.M.CHP	47pF	50V
C389	UB051470	C.CE.M.CHP	47pF	50V
C390	UB245100	C.CE.M.CHP	0.1uF	25V
C391	UB245100	C.CE.M.CHP	0.1uF	25V
C392	UB051470	C.CE.M.CHP	47pF	50V
C393	UB051470	C.CE.M.CHP	47pF	50V
C394	UB051470	C.CE.M.CHP	47pF	50V
C395	UB245100	C.CE.M.CHP	0.1uF	25V
C396	UB245100	C.CE.M.CHP	0.1uF	25V
C397	UB245100	C.CE.M.CHP	0.1uF	25V
C398	UB245100	C.CE.M.CHP	0.1uF	25V
C399	UB051470	C.CE.M.CHP	47pF	50V
C400	UB051470	C.CE.M.CHP	47pF	50V
C401	UB051470	C.CE.M.CHP	47pF	50V
C402	UB051470	C.CE.M.CHP	47pF	50V
C403	UB051470	C.CE.M.CHP	47pF	50V
C404	UB051470	C.CE.M.CHP	47pF	50V
C405	UB051470	C.CE.M.CHP	47pF	50V
C406	UB051470	C.CE.M.CHP	47pF	50V
C407	UB051470	C.CE.M.CHP	47pF	50V
C408	UB051470	C.CE.M.CHP	47pF	50V
C409	UB051470	C.CE.M.CHP	47pF	50V
C410	UB051470	C.CE.M.CHP	47pF	50V
C411	UB245100	C.CE.M.CHP	0.1uF	25V
C412	UB245100	C.CE.M.CHP	0.1uF	25V
* C413	UU147100	C.EL	10uF	25V
C414	UB245100	C.CE.M.CHP	0.1uF	25V
C415	UB245100	C.CE.M.CHP	0.1uF	25V
* C416	UU128100	C.EL	100uF	10V
C417	UB245100	C.CE.M.CHP	0.1uF	25V
* C418	UU128100	C.EL	100uF	10V
C419	UB245100	C.CE.M.CHP	0.1uF	25V
* C420	UU128100	C.EL	100uF	10V
C421	UB245100	C.CE.M.CHP	0.1uF	25V
C422	UB245100	C.CE.M.CHP	0.1uF	25V
* C423	UU128100	C.EL	100uF	10V
* C424	UU128100	C.EL	100uF	10V
C425	UB245100	C.CE.M.CHP	0.1uF	25V
* C426	UU128100	C.EL	100uF	10V
C427	UB245100	C.CE.M.CHP	0.1uF	25V
* C428	UU128100	C.EL	100uF	10V
C429	UB245100	C.CE.M.CHP	0.1uF	25V
C430	UB245100	C.CE.M.CHP	0.1uF	25V
* C431	UU128100	C.EL	100uF	10V
* C432	UU128100	C.EL	100uF	10V

* New Parts

P.C.B. DSP

Schm Ref.	PART NO.	Description		
C433	UB245100	C.CE.M.CHP	0.1uF	25V
* C434	UU128100	C.EL	100uF	10V
C901	VH053100	C.CE.TUBLR	0.1uF	50V
C902	VH053100	C.CE.TUBLR	0.1uF	50V
C903	VH053100	C.CE.TUBLR	0.1uF	50V
C904	VH053100	C.CE.TUBLR	0.1uF	50V
C905	VH053100	C.CE.TUBLR	0.1uF	50V
C906	VH053100	C.CE.TUBLR	0.1uF	50V
C907	UB245100	C.CE.M.CHP	0.1uF	25V
* C908	UU137100	C.EL	10uF	16V
C909	UB245100	C.CE.M.CHP	0.1uF	25V
C910	VH053100	C.CE.TUBLR	0.1uF	50V
C911	UB245100	C.CE.M.CHP	0.1uF	25V
* C912	UU167100	C.EL	10uF	50V
* C913	UU118330	C.EL	330uF	6.3V
C914	UB245100	C.CE.M.CHP	0.1uF	25V
C915	VJ901900	C.CE.M.CHP	100pF	50V
C916	UB245100	C.CE.M.CHP	0.1uF	25V
C917	VH053100	C.CE.TUBLR	0.1uF	50V
C918	VH053100	C.CE.TUBLR	0.1uF	50V
C921	VH053100	C.CE.TUBLR	0.1uF	50V
C922	VH053100	C.CE.TUBLR	0.1uF	50V
C923	VH053100	C.CE.TUBLR	0.1uF	50V
C924	VH053100	C.CE.TUBLR	0.1uF	50V
C925	VH053100	C.CE.TUBLR	0.1uF	50V
C926	VH053100	C.CE.TUBLR	0.1uF	50V
C927	VH053100	C.CE.TUBLR	0.1uF	50V
D1	VT332900	DIODE	1SS355	
D2	VT332900	DIODE	1SS355	
D3	VT332900	DIODE	1SS355	
D4	VT332900	DIODE	1SS355	
D5	VT332900	DIODE	1SS355	
D6	VT332900	DIODE	1SS355	
D7	VT332900	DIODE	1SS355	
D8	VT332900	DIODE	1SS355	
D9	VT332900	DIODE	1SS355	
D10	VT332900	DIODE	1SS355	
D11	VV220700	DIODE.SHOT	RB501V-40	
D12	VV220700	DIODE.SHOT	RB501V-40	
D13	VV220700	DIODE.SHOT	RB501V-40	
D14	VV220700	DIODE.SHOT	RB501V-40	
D15	VV220700	DIODE.SHOT	RB501V-40	
D16	VV220700	DIODE.SHOT	RB501V-40	
D17	VV220700	DIODE.SHOT	RB501V-40	
D18	VV220700	DIODE.SHOT	RB501V-40	
D19	VT332900	DIODE	1SS355	
D20	VT707700	C.TRIM	KV1851-TL	
D901	VG438300	DIODE.ZENR	MTZJ6.8B 6.8V	
* D902	V2598200	LED	SIR-505ST	
G1	VR463400	TERM.GND	D3.5 TP00385	
G2	VR463400	TERM.GND	D3.5 TP00385	
G3	VR463400	TERM.GND	D3.5 TP00385	
* IC1	XW504A00	IC	CPU,EPROM	

* New Parts

Schm Ref.	PART NO.	Description		
* IC2	XW526A00	IC		YSD917
* IC3	XW272A00	IC		AK5383-VS
IC4	XP250A00	IC		HD74HC00FPTR NAND
IC5	XU728A00	IC		YSS908-F
IC6	XV304B00	IC		YSS918D-F
* IC7	XV988A00	IC		YSS910-S
* IC8	XV988A00	IC		YSS910-S
* IC9	XV058A00	IC		DF1704E
* IC10	XV057A00	IC		PCM1704U
* IC11	XV057A00	IC		PCM1704U
* IC12	XV058A00	IC		DF1704E
* IC13	XV057A00	IC		PCM1704U
* IC14	XV057A00	IC		PCM1704U
* IC15	XV058A00	IC		DF1704E
* IC16	XV057A00	IC		PCM1704U
* IC17	XV057A00	IC		PCM1704U
* IC18	XV058A00	IC		DF1704E
* IC19	XV057A00	IC		PCM1704U
* IC20	XV057A00	IC		PCM1704U
* IC21	XV058A00	IC		DF1704E
* IC22	XV057A00	IC		PCM1704U
* IC23	XV057A00	IC		PCM1704U
IC24	XT958A00	IC		PM4007A
IC25	XV411A00	IC		W24258S-70LE-EL10
IC33	XV077A00	IC		MSM514260C-60JS
IC34	XV077A00	IC		MSM514260C-60JS
IC35	XV077A00	IC		MSM514260C-60JS
IC36	XP250A00	IC		HD74HC00FPTR NAND
IC37	XP250A00	IC		HD74HC00FPTR NAND
IC38	XF291A00	IC		uPC4570G2
* IC39	XD598A00	IC		TC74HCU04AFEL INV
* IC40	XD598A00	IC		TC74HCU04AFEL INV
IC41	XS776A00	IC		TC74HC126AF BUS BU
IC42	XQ248A00	IC		TC74HC125AF BUS BU
IC43	XV493A00	IC		HD74HC151FPEL
IC44	XV493A00	IC		HD74HC151FPEL
IC45	XR038A00	IC		NJM2904M OP AMP
IC46	XE518A00	IC		uPC4574G2
IC47	XF291A00	IC		uPC4570G2
IC48	XF291A00	IC		uPC4570G2
IC49	XF291A00	IC		uPC4570G2
IC50	XF291A00	IC		uPC4570G2
IC51	XF291A00	IC		uPC4570G2
IC52	XF291A00	IC		uPC4570G2
IC53	XF291A00	IC		uPC4570G2
IC54	XF291A00	IC		uPC4570G2
IC55	XF291A00	IC		uPC4570G2
IC56	XF291A00	IC		uPC4570G2
IC57	XP250A00	IC		HD74HC00FPTR NAND
* IC901	XY115A00	IC		M66004MAFP-200C
* IC902	XY115A00	IC		M66004MAFP-200C
L1	V2726500	COIL		68uH
L2	V2726500	COIL		68uH

* New Parts

P.C.B. DSP

Schm Ref.	PART NO.	Description	
L3	V2726500	COIL	68uH
L4	V2726500	COIL	68uH
L5	V2726500	COIL	68uH
L6	V2726500	COIL	68uH
L7	V2726500	COIL	68uH
L8	V2726500	COIL	68uH
L9	VT623200	FLTR.LC	SBP-4930
PJ1	VZ726300	JACK.PIN	2P
PJ2	VZ726400	JACK.PIN	2P
Q1	iA103700	TR.CHP	2SA1037 Q,R,S
Q2	VV556400	TR	2SC2412K Q,R,S
Q3	VV556400	TR	2SC2412K Q,R,S
Q4	VV556400	TR	2SC2412K Q,R,S
Q5	VV556400	TR	2SC2412K Q,R,S
Q6	iA103700	TR.CHP	2SA1037 Q,R,S
Q7	iA103700	TR.CHP	2SA1037 Q,R,S
Q8	VV556400	TR	2SC2412K Q,R,S
Q901	iC241200	TR.CHP	2SC2412K Q,R,S
Q902	iC241200	TR.CHP	2SC2412K Q,R,S
Q903	iC241200	TR.CHP	2SC2412K Q,R,S
Q904	iC241200	TR.CHP	2SC2412K Q,R,S
Q905	iC241200	TR.CHP	2SC2412K Q,R,S
Q906	iC241200	TR.CHP	2SC2412K Q,R,S
Q907	iC241200	TR.CHP	2SC2412K Q,R,S
Q908	iC241200	TR.CHP	2SC2412K Q,R,S
Q909	iC241200	TR.CHP	2SC2412K Q,R,S
Q910	iC241200	TR.CHP	2SC2412K Q,R,S
R12	Vi196500	R.MTL.CHP	4.3KΩ 1/10W
R13	Vi196500	R.MTL.CHP	4.3KΩ 1/10W
R39	Vi196600	R.MTL.CHP	4.7KΩ 1/10W
R41	Vi196600	R.MTL.CHP	4.7KΩ 1/10W
R42	Vi196600	R.MTL.CHP	4.7KΩ 1/10W
R43	Vi196600	R.MTL.CHP	4.7KΩ 1/10W
R44	Vi196600	R.MTL.CHP	4.7KΩ 1/10W
R46	Vi196600	R.MTL.CHP	4.7KΩ 1/10W
R60	HV453100	R.CAR.FP	1Ω 1/4W
R66	HV454220	R.CAR.FP	22Ω 1/4W
R67	Vi196600	R.MTL.CHP	4.7KΩ 1/10W
R68	Vi191800	R.MTL.CHP	51Ω 1/10W
R69	Vi191800	R.MTL.CHP	51Ω 1/10W
R70	Vi191800	R.MTL.CHP	51Ω 1/10W
R71	Vi191800	R.MTL.CHP	51Ω 1/10W
R72	Vi196600	R.MTL.CHP	4.7KΩ 1/10W
R73	HV454220	R.CAR.FP	22Ω 1/4W
R82	HV453220	R.CAR.FP	2.2Ω 1/4W
R84	HV453100	R.CAR.FP	1Ω 1/4W
R85	Vi197400	R.MTL.CHP	10KΩ 1/10W
R86	Vi197400	R.MTL.CHP	10KΩ 1/10W
R91	HV453100	R.CAR.FP	1Ω 1/4W
R92	HV453100	R.CAR.FP	1Ω 1/4W
R95	HV454330	R.CAR.FP	33Ω 1/4W
R118	HV453100	R.CAR.FP	1Ω 1/4W
R119	HV453100	R.CAR.FP	1Ω 1/4W

* New Parts

Schm Ref.	PART NO.	Description	
R138	Vi195900	R.MTL.CHP	2.7KΩ 1/10W
R139	HV454220	R.CAR.FP	22Ω 1/4W
R141	Vi200000	R.MTL.CHP	100KΩ 1/10W
R142	Vi194900	R.MTL.CHP	1KΩ 1/10W
R143	Vi194900	R.MTL.CHP	1KΩ 1/10W
R144	Vi194900	R.MTL.CHP	1KΩ 1/10W
R145	Vi192500	R.MTL.CHP	100Ω 1/10W
R148	Vi195900	R.MTL.CHP	2.7KΩ 1/10W
R149	Vi200000	R.MTL.CHP	100KΩ 1/10W
R150	Vi194900	R.MTL.CHP	1KΩ 1/10W
R151	Vi194900	R.MTL.CHP	1KΩ 1/10W
R152	Vi194900	R.MTL.CHP	1KΩ 1/10W
R153	HV454220	R.CAR.FP	22Ω 1/4W
R154	Vi192500	R.MTL.CHP	100Ω 1/10W
R155	HV454150	R.CAR.FP	15Ω 1/4W
R156	Vi196500	R.MTL.CHP	4.3KΩ 1/10W
R157	Vi200000	R.MTL.CHP	100KΩ 1/10W
R158	Vi194900	R.MTL.CHP	1KΩ 1/10W
R159	Vi194900	R.MTL.CHP	1KΩ 1/10W
R160	Vi194900	R.MTL.CHP	1KΩ 1/10W
R161	HV454220	R.CAR.FP	22Ω 1/4W
R162	Vi192500	R.MTL.CHP	100Ω 1/10W
R163	Vi196400	R.MTL.CHP	3.9KΩ 1/10W
R164	Vi200000	R.MTL.CHP	100KΩ 1/10W
R165	HV454220	R.CAR.FP	22Ω 1/4W
R167	HV454150	R.CAR.FP	15Ω 1/4W
R168	Vi194900	R.MTL.CHP	1KΩ 1/10W
R169	Vi194900	R.MTL.CHP	1KΩ 1/10W
R170	Vi194900	R.MTL.CHP	1KΩ 1/10W
R171	Vi192500	R.MTL.CHP	100Ω 1/10W
R172	Vi196500	R.MTL.CHP	4.3KΩ 1/10W
R173	Vi200000	R.MTL.CHP	100KΩ 1/10W
R174	Vi194900	R.MTL.CHP	1KΩ 1/10W
R175	Vi194900	R.MTL.CHP	1KΩ 1/10W
R176	Vi194900	R.MTL.CHP	1KΩ 1/10W
R177	HV454220	R.CAR.FP	22Ω 1/4W
R178	Vi192500	R.MTL.CHP	100Ω 1/10W
R179	Vi196500	R.MTL.CHP	4.3KΩ 1/10W
R180	Vi200000	R.MTL.CHP	100KΩ 1/10W
R181	Vi194900	R.MTL.CHP	1KΩ 1/10W
R182	Vi194900	R.MTL.CHP	1KΩ 1/10W
R183	Vi194900	R.MTL.CHP	1KΩ 1/10W
R184	HV454220	R.CAR.FP	22Ω 1/4W
R185	Vi192500	R.MTL.CHP	100Ω 1/10W
R186	HV454150	R.CAR.FP	15Ω 1/4W
R187	Vi196500	R.MTL.CHP	4.3KΩ 1/10W
R188	HV454220	R.CAR.FP	22Ω 1/4W
R189	Vi200000	R.MTL.CHP	100KΩ 1/10W
R190	Vi194900	R.MTL.CHP	1KΩ 1/10W
R191	Vi194900	R.MTL.CHP	1KΩ 1/10W
R192	Vi194900	R.MTL.CHP	1KΩ 1/10W
R193	Vi192500	R.MTL.CHP	100Ω 1/10W
R194	HV454150	R.CAR.FP	15Ω 1/4W

* New Parts

P.C.B. TUNER (Lead Type)

Schm Ref.	PART NO.	Description
	V2518600	P.C.B.
	V2518800	P.C.B.
	VQ961900	CN
CB4	VQ961900	CN
C1	VG288900	C.EL
C3	VG275800	C.CE.TUBLR
C4	VJ837200	C.EL
C5	VF467300	C.CE.TUBLR
C6	VJ837200	C.EL
C7	VJ839100	C.EL
C8	VF467300	C.CE.TUBLR
C9	VF467300	C.CE.TUBLR
C10	VF467300	C.CE.TUBLR
C11	VF467000	C.CE.TUBLR
C12	VJ836900	C.EL
C13	VJ836900	C.EL
C14	FG212100	C.CE
C15	VF467000	C.CE.TUBLR
C16	VF466700	C.CE.TUBLR
C17	VJ837200	C.EL
C19	VA760600	C.CE
C20	VG288900	C.EL
C21	VJ599000	C.CE.TUBLR
C22	VG290700	C.EL
C23	VF467300	C.CE.TUBLR
C24	UM416470	C.EL
C25	UM216330	C.EL
C26	VJ836900	C.EL
C27	VF467300	C.CE.TUBLR
C28	VA760600	C.CE
C29	VJ839100	C.EL
C30	VJ839100	C.EL
C31	VG288900	C.EL
C32	VJ839000	C.EL
C33	VJ839100	C.EL
C34	UA654470	C.MYLAR
C35	VG290700	C.EL
C36	UA652270	C.MYLAR
C36	UA653100	C.MYLAR
C37	UA652270	C.MYLAR
C37	UA653100	C.MYLAR
C38	VF466900	C.CE.TUBLR
C39	VG290900	C.EL
C40	VG290700	C.EL
C41	UA653390	C.MYLAR
C42	UM407220	C.EL
C43	UA653390	C.MYLAR
C44	VG290700	C.EL
C45	VJ837200	C.EL
C46	VJ837200	C.EL
C49	UA652120	C.MYLAR
C49	UA653220	C.MYLAR
C50	VJ599000	C.CE.TUBLR
D1	VD631600	DIODE

* New Parts

Schm Ref.	PART NO.	Description
D2	VD631600	DIODE
D3	VG437700	DIODE.ZENR
Fi1	GG000560	FLTR.CE
Fi2	GG000560	FLTR.CE
* Fi2	V4545200	FLTR.CE
Fi3	VC219000	FLTR.CE
IC1	XB760A00	IC
IC2	XQ944A00	IC
IC3	iG158100	IC
L1	Vi546100	COIL
L2	Vi546100	COIL
L3	Vi546100	COIL
L4	Vi546100	COIL
PK1	V2716700	TUNER.PK
PK1	V2909100	TUNER.PK
PK2	VU333700	COIL.RF.AM
Q1	iC053540	TR
Q2	iC053540	TR
Q3	VD678500	TR.DGT
Q4	iC174020	TR
Q5	VG722000	TR.DGT
Q6	iC1815C0	TR
Q7	VD678500	TR.DGT
R56	HV454470	R.CAR.FP
* T1	V3725400	COIL.DT
T2	VR895700	COIL.IF
T3	VT486800	COIL
T4	VQ138200	FLTR.LC
T5	VQ138200	FLTR.LC
TE1	VU477800	TERM.ANT
TP1	VT969000	PIN.TEST
TP2	VT969000	PIN.TEST
VR1	VJ694000	VR.TRIM
VR2	VJ694000	VR.TRIM
XL1	VY734600	RSNR.CRYS
XL2	GG000750	RSNR.CE
	BB071360	SCR.TERM
	VR282500	PLATE

* New Parts

P.C.B. TUNER (Lead Type & SMD)

Schm Ref.	PART NO.	Description		
*	V2519300	P.C.B.CHP	TUNER/TU-01(UC)	
*	V2519500	P.C.B.CHP	TUNER/TU-01(A)	
C1	VG287600	C.EL	100uF	25V
C3	UB050800	C.CE.M.CHP	8pF	50V
C4	UR837470	C.EL	47uF	16V
C5	UB044100	C.CE.M.CHP	0.01uF	50V
C6	UR837470	C.EL	47uF	16V
C7	UM416100	C.EL	1uF	50V
C8	UB044100	C.CE.M.CHP	0.01uF	50V
C9	UB044100	C.CE.M.CHP	0.01uF	50V
C10	UB044100	C.CE.M.CHP	0.01uF	50V
C11	UB013100	C.CE.M.CHP	1000pF	50V
C12	UM397100	C.EL	10uF	16V
C13	UM397100	C.EL	10uF	16V
C14	FG652100	C.CE	100pF	50V
C15	UB013100	C.CE.M.CHP	1000pF	50V
C16	UB051470	C.CE.M.CHP	47pF	50V
C17	UR837470	C.EL	47uF	16V
C19	V4006100	C.CE	10pF	50V
C20	VG287600	C.EL	100uF	25V
C21	UB044470	C.CE.M.CHP	0.047uF	50V
C22	VG290700	C.EL	3.3uF	50V
C23	UB044100	C.CE.M.CHP	0.01uF	50V
C24	UM406470	C.EL	4.7uF	50V
C25	UM416330	C.EL	3.3uF	50V
C26	UM397100	C.EL	10uF	16V
C27	UB044100	C.CE.M.CHP	0.01uF	50V
C28	VA760600	C.CE	10pF	50V
C29	UM416100	C.EL	1uF	50V
C30	UM416100	C.EL	1uF	50V
C31	VG287600	C.EL	100uF	25V
C32	UM415470	C.EL	0.47uF	50V
C33	UM416100	C.EL	1uF	50V
C34	UA954470	C.MYLAR	0.047uF	50V
C35	VG290700	C.EL	3.3uF	50V
C36	UA952270	C.MYLAR	270pF	50V(A)
C36	UA953100	C.MYLAR	1000pF	50V(UC)
C37	UA952270	C.MYLAR	270pF	50V(A)
C37	UA953100	C.MYLAR	1000pF	50V(U)
C38	UB012470	C.CE.M.CHP	470pF	50V
C39	VG287200	C.EL	10uF	50V
C40	VG290700	C.EL	3.3uF	50V
C41	UA953390	C.MYLAR	3900pF	50V
C42	UM397220	C.EL	22uF	25V
C43	UA953390	C.MYLAR	3900pF	50V
C44	VG290700	C.EL	3.3uF	50V
C45	UR837470	C.EL	47uF	16V
C46	UR837470	C.EL	47uF	16V
C47	UB012330	C.CE.M.CHP	330pF	50V
C48	UB012560	C.CE.M.CHP	560pF	50V
C49	UA952120	C.MYLAR	120pF	50V(A)
C49	UA953220	C.MYLAR	2200pF	50V(UC)
C50	UB044470	C.CE.M.CHP	0.047uF	50V

* New Parts

Schm Ref.	PART NO.	Description		
C51	UR837470	C.EL	47uF	16V
C52	UR837470	C.EL	47uF	16V
C53	UR837470	C.EL	47uF	16V
C54	VA761100	C.CE	27pF	50V
C55	VA761100	C.CE	27pF	50V
C56	UB044470	C.CE.M.CHP	0.047uF	50V
C57	UB012330	C.CE.M.CHP	330pF	50V
CB4	VQ961900	CN	16P	
D1	VT332900	DIODE	1SS355	
D2	VT332900	DIODE	1SS355	
D3	VU172000	DIODE.ZENR	UDZS5.6BTE-17	5.6V
Fi1	GG000560	FLTR.CE	SFE10.7MS3GHY-A	
Fi2	GG000560	FLTR.CE	SFE10.7MS3GHY-A	
Fi3	VC219000	FLTR.CE	SFZ450JL3	
IC1	XB760A00	IC	LA1266	
IC2	XQ944A00	IC	LC72131	
IC3	iG158100	IC	LA3401	
L1	VU889500	COIL	220uH	
L2	VU889500	COIL	220uH	
L3	VU889500	COIL	220uH	
L4	VU889500	COIL	220uH	
L5	VU889500	COIL	220uH	
PK1	V2716700	TUNER.PK	ENV-172A4G1(A)	
PK1	V2909100	TUNER.PK	ENV-172C8G1R(UC)	
PK2	VU333700	COIL.RF.AM	940536051A	
Q1	iC053540	TR	2SC535 A,B,C	
Q2	iC053540	TR	2SC535 A,B,C	
Q3	VD678500	TR.DGT	DTA114ES	
Q4	iC174020	TR	2SC1740S R,S	
Q5	VG722000	TR.DGT	DTC144ES	
Q6	iC181510	TR	2SC1815 Y	
Q7	VD678500	TR.DGT	DTA114ES	
R56	HV754470	R.CAR.FP	47Ω	1/4W
* T1	V3725400	COIL.DT	10.7MHZ	104A
T2	VR895700	COIL.IF	450KHz	
T3	VT486800	COIL	XYA2(A)	
T4	VQ138200	FLTR.LC	19KHz	
T5	VQ138200	FLTR.LC	19KHz	
TE1	VU477800	TERM.ANT	AJ-2038-040	
TP1	VT969000	PIN.TEST	IRS-2049	
TP2	VT969000	PIN.TEST	IRS-2049	
VR1	VJ694000	VR.TRIM	B47KΩ	
VR2	VJ694000	VR.TRIM	B47KΩ	
XL1	VY734600	RSNR.CRYS	7.2MHz	
XL2	GG000750	RSNR.CE	18.95KHz	
XL3	V3930900	RSNR.CRYS	4.332MHz	
	BB071360	SCR.TERM	8.3x13	
	VR282500	PLATE	ANT.	

* New Parts

CHIP RESISTOR

Schm Ref.	PART NO.	Description	Schm Ref.	PART NO.	Description
	RD250000	R.CAR.CHP 0Ω			
	RD253100	R.CAR.CHP 1Ω			
	RD253220	R.CAR.CHP 2.2Ω			
	RD253470	R.CAR.CHP 4.7Ω			
	RD254100	R.CAR.CHP 10Ω			
	RD254330	R.CAR.CHP 33Ω			
	RD254470	R.CAR.CHP 47Ω			
	RD254680	R.CAR.CHP 68Ω			
	RD254750	R.CAR.CHP 75Ω			
	RD254820	R.CAR.CHP 82Ω			
	RD255100	R.CAR.CHP 100Ω			
	RD255120	R.CAR.CHP 120Ω			
	RD255150	R.CAR.CHP 150Ω			
	RD255220	R.CAR.CHP 220Ω			
	RD255330	R.CAR.CHP 330Ω			
	RD255470	R.CAR.CHP 470Ω			
	RD255560	R.CAR.CHP 560Ω			
	RD255680	R.CAR.CHP 680Ω			
	RD255820	R.CAR.CHP 820Ω			
	RD256100	R.CAR.CHP 1KΩ			
	RD256120	R.CAR.CHP 1.2KΩ			
	RD256180	R.CAR.CHP 1.8KΩ			
	RD256200	R.CAR.CHP 2KΩ			
	RD256220	R.CAR.CHP 2.2KΩ			
	RD256270	R.CAR.CHP 2.7KΩ			
	RD256330	R.CAR.CHP 3.3KΩ			
	RD256430	R.CAR.CHP 4.3KΩ			
	RD256470	R.CAR.CHP 4.7KΩ			
	RD256510	R.CAR.CHP 5.1KΩ			
	RD256680	R.CAR.CHP 6.8KΩ			
	RD256750	R.CAR.CHP 7.5KΩ			
	RD256820	R.CAR.CHP 8.2KΩ			
	RD257100	R.CAR.CHP 10KΩ			
	RD257120	R.CAR.CHP 12KΩ			
	RD257150	R.CAR.CHP 15KΩ			
	RD257180	R.CAR.CHP 18KΩ			
	RD257220	R.CAR.CHP 22KΩ			
	RD257270	R.CAR.CHP 27KΩ			
	RD257330	R.CAR.CHP 33KΩ			
	RD257470	R.CAR.CHP 47KΩ			
	RD257680	R.CAR.CHP 68KΩ			
	RD258100	R.CAR.CHP 100KΩ			
	RD258220	R.CAR.CHP 220KΩ			
	RD258470	R.CAR.CHP 470KΩ			
	RD258680	R.CAR.CHP 680KΩ			
	RD259100	R.CAR.CHP 1MΩ			
	RD259220	R.CAR.CHP 2.2MΩ			

* New Parts

* New Parts

DSP-AX1/RX-V1

EXPLODED VIEW

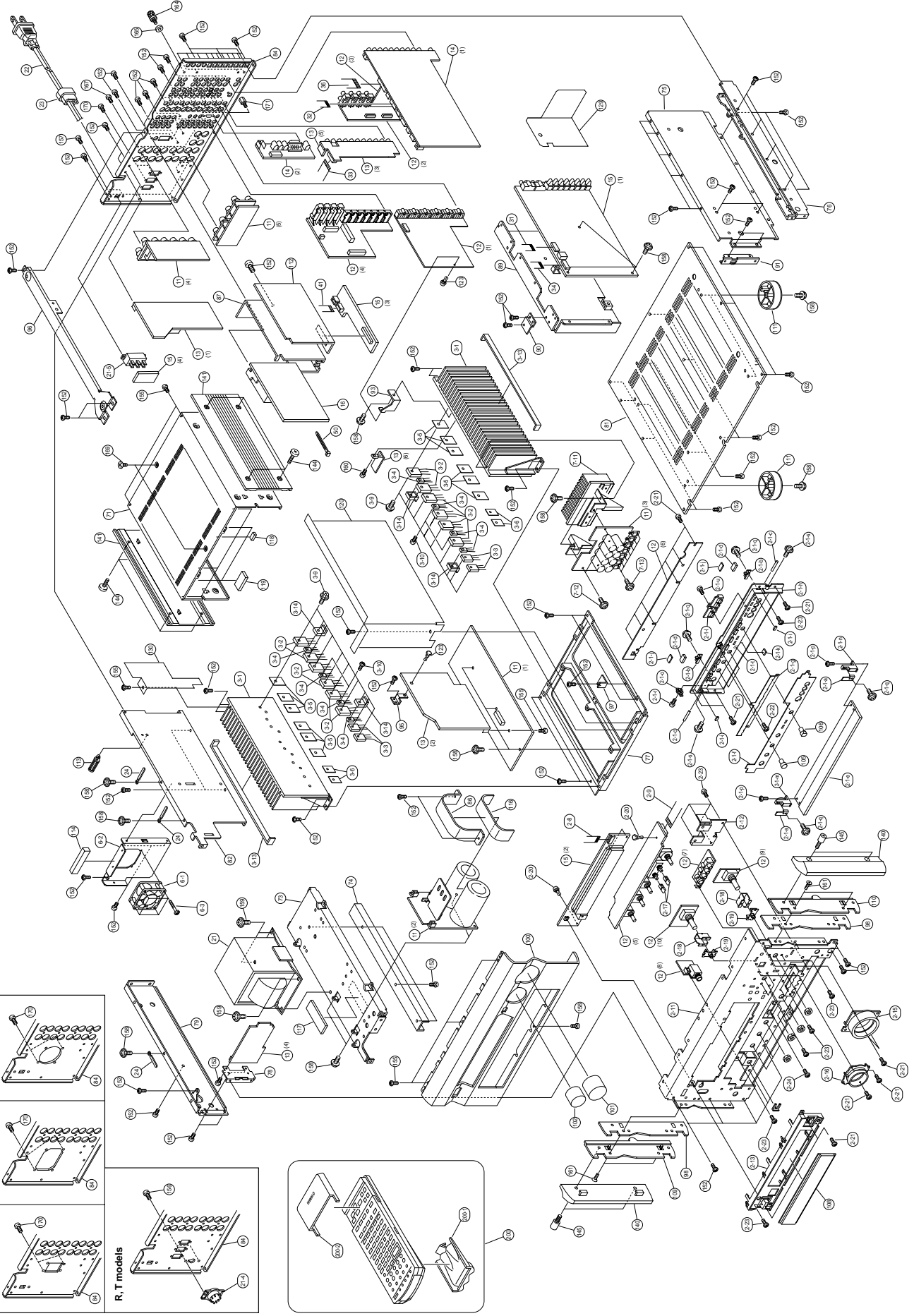
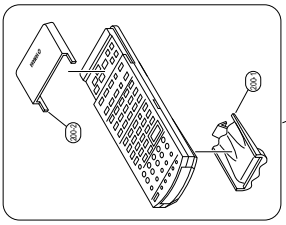
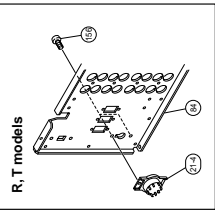
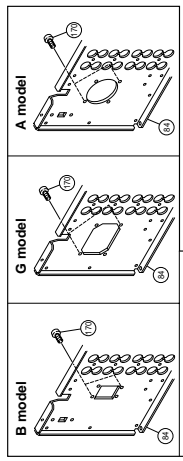

MECHANICAL PARTS

Ref. No.	PART NO.	Description	Remarks	Markets
2-1a	VZ619800	SUPPORT		
2-1b	VZ830500	SUPPORT		
2-1c	VZ621800	SHAFT		
2-1d	VZ621900	MAGNET		
2-1e	V4321400	PANEL, LID	BL	
2-1f	V4321600	PANEL, LID	GD	
2-1g	V4324400	PLATE, L	RX-V1 BL	(UCA)
2-1h	V4324700	PLATE, L	RX-V1 GD	(UCA)
2-1i	V4481600	PLATE, L	DSP-AX1 BL	(RBGT)
2-1j	V4481800	PLATE, L	DSP-AX1 GD	(RBGT)
2-1k	V4324800	PLATE, SP	RX-V1 BL	(UCA)
2-1l	V4325000	PLATE, SP	RX-V1 GD	(UCA)
2-1m	V4516800	PLATE, SP	DSP-AX1 BL	(RBGT)
2-1n	V4517000	PLATE, SP	DSP-AX1 GD	(RBGT)
2-1o	V4328200	CASE, SUB PANEL	BL	
2-1p	V4328400	CASE, SUB PANEL	GD	
2-1q	V2048500	CUSHION, LID	GD	
2-1r	V7062900	CUSHION	BL	
2-1s	VZ875000	SPACER		
2-1t	VH625500	DAMPER		
2-1u	V4481100	BUTTON, TU		
2-1v	V4481300	BUTTON, TU	RX-V1 BL	(UCA)
2-1w	V4329400	HINGE, R	RX-V1 GD	(UCA)
2-1x	V4329600	HINGE, R	BL	
2-1y	V0047400	HINDGE	GD	
2-1z	VZ629400	HINDGE	GD	
2-2a	V5095100	DAMPER, GEAR	BL	
2-2b	ED330066	BIND HEAD SCREW		
2-2c	EK930010	PW HEAD B-TITE SCREW		
2-2d	VG893900	BIND HEAD P-TITE SCREW		
2-2e	VE529700	PW HEAD B-TITE SCREW		
2-2f	V3217600	PLATE, GROUND		
2-2g	EP600190	BIND HEAD B-TITE SCREW		
2-2h	MF116250	FLEXIBLE FLAT CABLE		
2-2i	MF117200	FLEXIBLE FLAT CABLE		
2-2j	V4318400	SUB CHASSIS		
2-2k	V4481900	SUPPORT, PJ		
2-2l	V4328700	BUTTON CASE	BL	
2-2m	V4328900	BUTTON CASE	GD	
2-2n	V4323100	ESCUITCHEON, VOL	BL	
2-2o	V4323300	ESCUITCHEON, VOL	GD	
2-2p	VZ625900	ESCUITCHEON, SEL	BL	
2-2q	VZ756800	ESCUITCHEON, SEL	GD	
2-2r	V2467300	BUTTON	BL	
2-2s	V2467500	BUTTON	GD	
2-2t	V5181000	SUPPORT		
2-2u	V5181200	SUPPORT		
2-2v	CB605620	PLASTIC RIVET		
2-2w	EP600190	BIND HEAD B-TITE SCREW		
2-2x	VR145000	BIND HEAD BONDING TAP, SCREW	3x8 ZMC2-BL	
2-2y	VN413300	BIND HEAD BONDING B-T. SCREW	3x12 MFZN2-BL	
2-2z	ED330066	BIND HEAD SCREW	3x8 MFZN2-BL	
3-1	V4325100	HEAT SINK ASSY, L	3x6 FCRM3-BL	
3-2	V4325100	HEAT SINK ASSY, R	52BS300-L130ASSY	

* New Parts

Ref. No.	PART NO.	Description	Remarks	Markets
3-1	V4766700	HEAT SINK ASSY, R		
3-2	V4863600	PAIR TRANSISTOR		
3-3	V4863600	PAIR TRANSISTOR		
3-3A	IX615750	TRANSISTOR		
3-3C	IX615760	TRANSISTOR		
3-4	VC398100	TRANSISTOR		
3-4	VC398100	TRANSISTOR		
3-4	VC398100	TRANSISTOR		
3-5	VK195900	SHEET		
3-6	VK195900	SHEET		
3-9	VK173200	SCREW, TRANSISTOR		
3-10	VK697600	BIND HEAD B-TITE SCREW		
3-13	VU195800	DAMPER, FIN		
3-14	V5120300	SUPPORT, PCB		
6-1	V3316600	DC BRUSHLESS FAN		
6-2	VZ619400	SUPPORT		
6-3	VV220300	BIND HEAD B-TITE SCREW		
7-11	V4326200	HEAT SINK, L		
7-12	EK930010	PW HEAD B-TITE SCREW		
7-13	VK697600	BIND HEAD B-TITE SCREW		
11	V5001000	P.C.B. ASSY		
11	V5001100	P.C.B. ASSY		
11	V5001200	P.C.B. ASSY		
11	V5001300	P.C.B. ASSY		
11	V5001400	P.C.B. ASSY		
12	V5001600	P.C.B. ASSY		
12	V5001700	P.C.B. ASSY		
12	V5001800	P.C.B. ASSY		
12	V5001900	P.C.B. ASSY		
13	V5002100	P.C.B. ASSY		
13	V5002200	P.C.B. ASSY		
13	V5002300	P.C.B. ASSY		
13	V5002400	P.C.B. ASSY		
13	V5003500	P.C.B. ASSY		
13	V5003600	P.C.B. ASSY		
14	V5002600	P.C.B. ASSY		
14	V5002700	P.C.B. ASSY		
14	V5002800	P.C.B. ASSY		
14	V5002900	P.C.B. ASSY		
15	V5003000	P.C.B. ASSY		
15	V5003100	P.C.B. ASSY		
15	V5003200	P.C.B. ASSY		
16	V2518600	P.C.B. ASSY		
16	V2518800	P.C.B. ASSY		
16	V2519300	P.C.B. ASSY		
16	V2519500	P.C.B. ASSY		
21	XW967A00	POWER TRANSFORMER		
21	XW968A00	POWER TRANSFORMER		
21	XW969A00	POWER TRANSFORMER		
21	XW970A00	POWER TRANSFORMER		
21	XW971A00	POWER TRANSFORMER		
21-4	V449800	VOLTAGE SELECTOR		
21-5	VZ855600	SLIDE SWITCH		

* New Parts

Ref. No.	PART NO.	Description	Remarks	Markets
* 22	V5069600	POWER CORD ASSY		(UC)
* 22	VP418300	POWER CORD ASSY		(A)
* 22	V5759300	POWER CORD ASSY		(G)
* 22	VU411300	POWER CORD ASSY		(B)
* 22	VZ542500	POWER CORD ASSY		(RT)
23	VN158600	CORD STOPPER	No.2104	(RABGT)
23	VQ583400	CORD STOPPER	No.2272	(UC)
24	CB502030	BINDING TIE	S-75B	
31	MF108080	FLEXIBLE FLAT CABLE	8P 80mm	
32	MF111400	FLEXIBLE FLAT CABLE	11P 400mm	
33	MF116060	FLEXIBLE FLAT CABLE	16P 60mm	
34	MF116250	FLEXIBLE FLAT CABLE	16P 250mm	
36	MF127350	FLEXIBLE FLAT CABLE	27P 350mm	
* 41	V4868500	CONNECTOR, FLAT CABLE	13P 450mm	(UCA)
50	CB069250	BINDING TIE	BK-1	
* 71	V4318100	TOP COVER		BL
* 71	V4318300	TOP COVER		GD
73	VZ618000	FRAME	L	
* 75	V4318600	FRAME, L/SF		
* 76	V4318500	FRAME	R/UPPER	
* 77	V4600900	FRAME CENTER	R/LOWER	
* 78	V4320400	SUPPORT, A	SUB	
* 79	V4318800	FRAME	SL	
* 81	V4803700	BOTTOM COVER	CF	
* 82	V4318900	FRAME		(U)
* 84	V4319100	REAR PANEL		(C)
* 84	V4319200	REAR PANEL		(A)
* 84	V4319400	REAR PANEL		(RT)
* 84	V4563300	REAR PANEL		(G)
* 84	V4563500	REAR PANEL		(B)
* 84	V4563600	REAR PANEL		(UCA)
86	VZ764400	SUPPORT	CMCN	
* 87	V4847300	SHIELD CASE		
* 89	V4318700	SHIELD CASE		
* 90	V4320200	SUPPORT	I/PCB	
91	VT989700	SUPPORT	R/R	
* 93	V4320300	SUPPORT	S/PCB	
* 95	V4847400	SUPPORT	C/PCB	
* 96	V4319700	FRAME	C/UP	
* 97	V4949800	SUPPORT	F/PCB	
* 98	V4320100	SUPPORT, SIDE	AA	
* 100	V4321000	FRONT PANEL		(UCA)
* 100	V4321200	FRONT PANEL		(UCA)
* 100	V4515100	FRONT PANEL	DSP-AX1 BL	(RABGT)
* 100	V4515300	FRONT PANEL	DSP-AX1 GD	(RABGT)
* 101	V4322200	NOB, D45	BL	GD
* 101	V4322500	NOB, D45	GD	GD
* 102	V5541300	NOB	BL	BL
105	V5757200	NOB	D12P	BL
105	VZ891300	NOB	D12P	GD
106	VT275100	NOB	D12R	BL

* New Parts

Ref. No.	PART NO.	Description	Remarks	Markets
106	VZ891400	KNOB	GD	
* 108	V4329700	WINDOW PANEL, LID		
* 109	V4329300	PLATE SIDE/H190		
* 110	V4665700	PLATE	CB	
111	V0042500	LEG	GD	
111	V5025000	LEG	BL	
* 112	V5126500	SHIELD PLATE	RX-V1	(UCA)
* 113	V5118300	SPACER		
114	VZ822300	CUSHION, FAN		
116	VZ764800	DAMPER	BLACK	
117	VK492200	DAMPER	A	
118	VE222800	CUSHION	TOP	
119	VK706800	DAMPER		
* 120	V4867300	PLATE/FUNC	No.1781	
123	CB605620	PLASTIC RIVET		
* 129	V5177100	PLATE/DSP		
* 130	V5177200	PLATE/HEAT		
* 140	V4321800	PANEL, SIDE	BL	
* 140	V4322000	PANEL, SIDE	GD	
* 141	V4563800	SIDE PANEL	BL	
* 141	V4564000	SIDE PANEL	GD	
* 144	V4656000	FLAT FILLISTER HEAD SCREW	4x12-10 MFZN2-BL	
* 144	V4656200	FLAT FILLISTER HEAD SCREW	4x12-10 MFNI33	
* 145	V4656300	SPECIAL SCREW	4-7 MFZN2-BL	
* 145	V4656500	SPECIAL SCREW	4-7 MFNI33	
152	VN413300	BIND HEAD BONDING B-T, SCREW	3x8 MFZN2-BL	
155	EP600190	BIND HEAD B-TITE SCREW	3x8 ZMC2-BL	(R)
156	ED330066	BIND HEAD SCREW	3x6 FCRM3-BL	(C)
157	EP600530	BIND HEAD S-TITE SCREW	3x8 ZMC2-BL	
158	EK930010	PW HEAD B-TITE SCREW	3x8-8 FCRM3-BL	
159	VK625000	CUP S-TITE SCREW	5x10-12 ZMC2-Y	
160	VK697600	BIND HEAD B-TITE SCREW	3x10 SP ZMC2-Y	
161	EP600790	FLAT HEAD B-TITE SCREW	3x8 MFZN2-BL	
164	AA627310	GROUND TERMINAL	3.6x10x0.8 FNM3-3G	
165	EV265560	PLAIN WASHER	3x10 MFNI33	
167	VY731200	BONDING HEAD TAPPING SCREW	4x8-10 FCRM3-BL	
169	EX601850	SPECIAL SCREW S-TITE	4x8-10 MFNI-33	BL
169	VZ893000	DECORATED SCREW S-TIGHT	GD	
170	EP600220	BIND HEAD B-TITE SCREW	3x10 ZMC2-Y	
* 171	V3768900	SCREW, LOCK	17L-003C41	
* 200	V4565600	ACCESSORIES	RAV220	
200-1	AAAX12830	REMOTE CONTROL TRANSMITTER LID	103RRR-170-01R SMK	
200-2	VG850700	SLIDE COVER	103RRR-171-01R SMK	
	VQ307400	ANTENNA, FM	1.4m	RX-V1
	VT948000	ANTENNA ADAPTER	81-653-645-110	RX-V1
		BATTERY (ALKALINE DRY)	1.5V LR6(3S)AG	(UC)

* New Parts

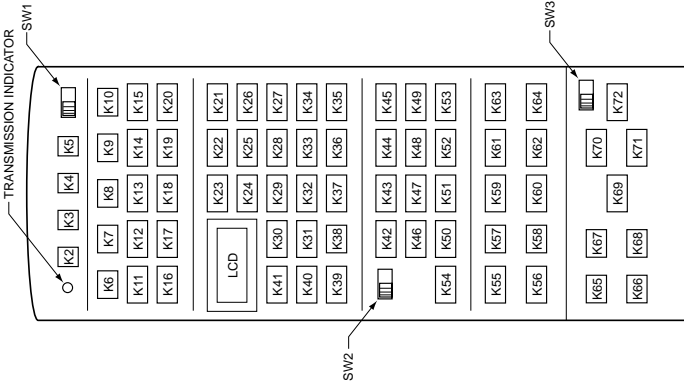
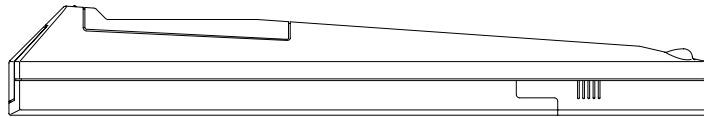
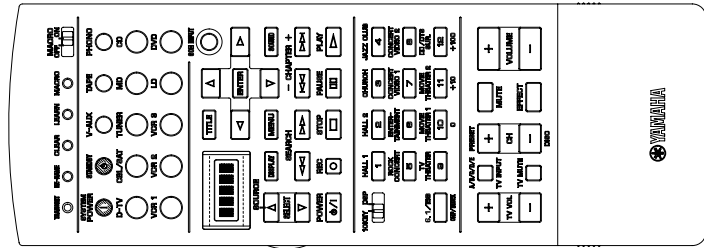
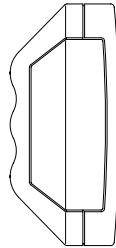

Key arrangement

Initial code of Yamaha/ヤマハ初期コード・・・1/2

*1: Those code are transmitted when "DSP" is set-up as AMP library.
AMPライブラリをDSPに設定することで送信される。
*2: Those code are transmitted when "Zone2" is chosen with Select key.
SelectキーによってZone2を選択することで送信される。

*: Transmitting Code of K6, "7A-1D"
K6送信コード: 7A-1Dにおいて
Full word transmitted twice.
フルワード2回送信される。
Devices not mentioned on this table has no initial code.
本表に記載されていないデバイスは、初期コードはなし。

Key No.	Key Name	YPC	DSP #1	Zone2 #2
1	RE-NAME	---	---	---
2	CLEAR	---	---	---
3	LEARN	---	---	---
5	MACRO	---	---	---
6	POWER on	7A-1D	7D-90	7A-1D
7	STANDBY	7A-1E	7D-91	7A-1E
8	VAUX	7A-55	7D-8A	7A-D8
9	TAPE	7A-18	7D-8B	7A-D3
10	PHONO	7A-14	7D-98	7A-D0
11	DTV	7A-54	7D-84	7A-D9
12	SBSAT	7A-00	7D-96	7A-C0
13	TUNER	7A-09	7D-98	7A-C2
14	LD	7A-15	7D-87	7A-D1
15	CD	7A-0F	7D-81	7A-D7
17	VCR1	7A-13	7D-82	7A-D5
18	VCR3	7A-08	7D-85	7A-C6
19	LD	7A-17	7D-83	7A-D5
20	DVD	7A-C1	7D-97	7A-C0
21	EXT. DEC.	7A-87	7D-8C	7A-87
Device				
22	Up	7C-B4	---	---
23	TITLE	7C-B1	---	---
24	Left	7C-B5	---	---
25	Enter	7C-B8	---	---
26	Right	7C-B6	---	---
27	SOUND	7C-AD	7C-12	---
28	Down	7C-B3	---	---
29	MENU	7C-B2	---	---
30	DISPLAY	7C-13	7D-0A	7A-45
31	STOP	7C-86	7A-09	7A-01
32	SKIP	7C-97	7A-0E	7A-02
33	SKIP	7C-99	7A-0E	7A-02
34	SKIP	7C-98	7A-0B	7A-0B
35	PLAY	7C-8A	7C-03	7A-0A
36	PAUSE	7C-82	7C-05	7A-08
37	STOP	7C-83	7C-5A	7A-09
38	REC	7C-85	7C-5B	7A-0A
39	POWER	7C-87	---	---
40	SELECT down	---	---	---
41	SELECT up	---	---	---

Initial code of Yamaha/ヤマハ初期コード・・・2/2

Key No.	Key Name	YPC	DSP #1	Zone2 #2	DVD	LD	CD	MD	TUNER	TAPE
42	PRG1	7A-88	DSP	7A-88	7C-94	7C-17	79-11	79-65	7A-85	---
43	PRG2	7A-89	DSP	7D-D1	7A-89	7C-95	7C-18	79-12	79-66	7A-85
44	PRG3	7A-8A	DSP	7D-D2	7A-8A	7C-96	7C-19	79-13	79-67	7A-E7
45	PRG4	7A-8B	DSP	7D-D3	7A-8B	7C-97	7C-1A	79-14	79-68	7A-E8
46	PRG5	7A-8C	DSP	7D-D4	7A-8C	7C-98	7C-1B	79-15	79-69	7A-E9
47	PRG6	7A-8D	DSP	7D-D5	7A-8D	7C-99	7C-1C	79-16	79-70	7A-EA
48	PRG7	7A-8E	DSP	7D-D6	7A-8E	7C-9A	7C-1D	79-17	79-6A	7A-EB
49	PRG8	7A-8F	DSP	7D-D7	7A-8F	7C-9B	7C-1E	79-18	79-6B	7A-EC
50	PRG9	7A-90	DSP	7D-D8	7A-90	7C-9C	7C-1F	79-19	79-6C	7A-ED
51	PRG10	7A-91	DSP	7D-D9	7A-91	7C-9D	7C-16	79-10	79-6E	7A-F2
52	PRG11	7A-92	DSP	7D-0A	7A-92	7C-9D	7C-5D	79-1A	79-6F	7A-F3
53	PRG12	7A-93	DSP	7D-0B	7A-93	7C-9E	7C-5E	79-0B	---	7A-F4
54	Extra	7A-97	DSP	7D-0F	7A-97	7C-9E	7C-15	79-0D	---	7A-F0
55	TV VOL up	---	---	---	---	---	---	---	---	---
56	TV VOL down	---	---	---	---	---	---	---	---	---
57	TV INPUT	---	---	---	---	---	---	---	---	---
58	TV MUTE	---	---	---	---	---	---	---	---	---
59	CH up	---	---	---	---	---	---	---	---	---
60	CH down	---	---	---	---	---	---	---	---	---
61	MUTE	7A-1C	7D-94	7A-DC	7C-8B	---	---	---	---	---
62	EFFECT	7A-56	7D-C1	7A-56	7C-8A	---	---	---	---	---
63	VOL up	7A-1A	7D-8D	7A-DA	7C-8A	---	---	---	---	---
64	VOL down	7A-1B	7D-8E	7A-DB	7C-8A	---	---	---	---	---
SW3										
65	ON SCREEN	7A-57	7D-C2	7A-C3	---	---	---	---	---	---
66	SLEEP	7A-57	7D-93	7A-57	---	---	---	---	---	---
67	LEVEL	7A-86	7D-95	7A-86	---	---	---	---	---	---
68	TEST	7A-85	7D-CA	7A-85	---	---	---	---	---	---
69	LEFT	7A-C7	7A-9F	7D-C7	7D-9F	7A-C7	7A-9F	---	---	---
70	UP	7A-C5	7A-9D	7D-C5	7D-9D	7A-C5	7A-9D	---	---	---
71	DOWN	7A-C4	7A-9C	7D-C4	7D-9C	7A-C4	7A-9C	---	---	---
72	RIGHT	7A-C6	7A-9E	7D-C6	7D-9E	7A-C6	7A-9E	---	---	---

Key type table/キー種別表

No.	Key Name	Learn	Macro	Device	Illustration
#1	#2	#3	#4		
1	RE-NAME	—	—	—	—
2	CLEAR	—	—	—	—
3	LEARN	—	—	—	—
4	POWER on	—	—	—	—
5	STANDBY	—	—	—	—
6	TAPE	—	—	—	—
7	PHONO	—	—	—	—
8	D-TV	—	—	—	—
9	CBSAT	—	—	—	—
10	TUNER	—	—	—	—
11	CD	—	—	—	—
12	VCR1	—	—	—	—
13	VCR2	—	—	—	—
14	VCR3	—	—	—	—
15	LD	—	—	—	—
16	DVD	—	—	—	—
17	EXT. DEC.	—	—	—	—
18	TITLE	—	—	—	—
19	Left	—	—	—	—
20	Enter	—	—	—	—
21	Right	—	—	—	—
22	SOUND	—	—	—	—
23	Down	—	—	—	—
24	Menu	—	—	—	—
25	DISPLAY	—	—	—	—
26	REWSEARCH	—	—	—	—
27	CH/PSKIP-	—	—	—	—
28	CH/PSKIP+	—	—	—	—
29	PAUSE	—	—	—	—
30	STOP	—	—	—	—
31	REC	—	—	—	—
32	POWER	—	—	—	—
33	SELECT up	—	—	—	—
34	EXT. DEC.	—	—	—	—
35	TITLE	—	—	—	—
36	Left	—	—	—	—
37	Enter	—	—	—	—
38	Right	—	—	—	—
39	SOUND	—	—	—	—
40	Down	—	—	—	—
41	Menu	—	—	—	—
42	DISPLAY	—	—	—	—
43	REWSEARCH	—	—	—	—
44	CH/PSKIP-	—	—	—	—
45	CH/PSKIP+	—	—	—	—
46	PAUSE	—	—	—	—
47	STOP	—	—	—	—
48	REC	—	—	—	—
49	POWER	—	—	—	—
50	SELECT down	—	—	—	—
51	EXT. DEC.	—	—	—	—
52	TITLE	—	—	—	—
53	Left	—	—	—	—
54	Enter	—	—	—	—
55	Right	—	—	—	—
56	SOUND	—	—	—	—
57	Down	—	—	—	—
58	Menu	—	—	—	—
59	DISPLAY	—	—	—	—
60	REWSEARCH	—	—	—	—
61	CH/PSKIP-	—	—	—	—
62	CH/PSKIP+	—	—	—	—
63	PAUSE	—	—	—	—
64	STOP	—	—	—	—
65	REC	—	—	—	—
66	POWER	—	—	—	—
67	SELECT up	—	—	—	—
68	EXT. DEC.	—	—	—	—
69	TITLE	—	—	—	—
70	Left	—	—	—	—
71	Enter	—	—	—	—
72	Right	—	—	—	—

*1: The key which has O is learning key.
 Oのキーは学習可能キー
 *2: The key which has O is Macro transmitting key.
 Oのキーはマクロ送信可能キー
 *3: The key which has O is for Device select.
 Oのキーはデバイス選択キー
 *4: The key which has D** is illuminated key.
 D**表記のあるキーは発光キー
 (O** : LED Assign/LED アサインを示す)

Key Function of K22・K60/K22~K600キーファンクション

Device	DVD	LD	VCR3	VCR2	VCR1	CD	MD	TUNER	CBSAT	D-TV	PHONO	TAPE	VAUX	OPTN
22 Up	Menu up	—	—	—	—	—	—	—	Menu up	—	—	—	—	—
23 TITLE	Title	—	—	—	—	—	—	—	—	—	—	—	—	—
24 Left	Menu left	—	—	—	—	—	—	—	Menu left	—	—	—	—	—
25 Enter	Menu enter	—	—	—	—	—	—	—	Menu select	—	—	—	—	—
26 Right	Menu right	—	—	—	—	—	—	—	Menu right	—	—	—	—	—
27 SOUND	Audio	—	—	—	—	—	—	—	—	—	—	A/B	—	—
28 Down	Menu down	—	—	—	—	—	—	—	Menu down	—	—	—	—	—
29 MENU	MENU	—	—	—	—	—	—	—	MENU	—	—	—	—	—
30 DISPLAY	Display	—	—	—	—	—	—	—	Display	—	—	—	—	—
31 REWSEARCH	Rew	FF	Rew	FF	Rew	FF	FF	FF	Display (VCR1 Rew)	—	—	Rew	—	—
32 CH/PSKIP-	FF	FF	FF	FF	FF	FF	FF	FF	(VCR1 FF)	—	—	FF	—	—
33 CH/PSKIP+	Chap/Skip-	Chap/Skip-	Chap/Skip-	Chap/Skip-	Chap/Skip-	Chap/Skip-	Chap/Skip-	Chap/Skip-	(VCR1 FF)	—	—	FF	—	—
34 PAUSE	Play	Play	Play	Play	Play	Play	Play	Play	(VCR1 Play)	—	—	Play	—	—
35 PLAY	Pause	Pause	Pause	Pause	Pause	Pause	Pause	Pause	(VCR1 Pause)	—	—	Pause	—	—
36 PAUSE	Stop	Stop	Stop	Stop	Stop	Stop	Stop	Stop	(VCR1 Stop)	—	—	Stop	—	—
37 STOP	Return	Return	REC	REC	REC	REC	REC	REC	(VCR1 Stop)	—	—	Stop	—	—
38 REC	Power	Power	Power	Power	Power	Power	Power	Power	(VCR1 REC)	—	—	Power	—	—
39 POWER	Power	Power	Power	Power	Power	Power	Power	Power	(VCR1 REC)	—	—	Power	—	—
40 SELECT down	Device select down	—	—	—	—	—	—	—	Power	—	—	Power	—	—
41 SELECT up	Device select up	—	—	—	—	—	—	—	Power	—	—	Power	—	—
42 PRG1	1	1	1	1	1	1	1	1	P1	1	1	—	—	—
43 PRG2	2	2	2	2	2	2	2	2	P2	2	2	—	—	—
44 PRG3	3	3	3	3	3	3	3	3	P3	3	3	—	—	—
45 PRG4	4	4	4	4	4	4	4	4	P4	4	4	—	—	—
46 PRG5	5	5	5	5	5	5	5	5	P5	5	5	—	—	—
47 PRG6	6	6	6	6	6	6	6	6	P6	6	6	—	—	—
48 PRG7	7	7	7	7	7	7	7	7	P7	7	7	—	—	—
49 PRG8	8	8	8	8	8	8	8	8	P8	8	8	—	—	—
50 PRG9	9	9	9	9	9	9	9	9	P9	9	9	—	—	—
51 PRG10	0	0	0/10	0/10	0/10	0	0	0	P0	0	0	—	—	—
52 PRG11	+10	+10	0/10	0/10	0/10	+10	+10	+10	P10	0/10	—	—	—	—
53 PRG12	Clear	Clear	Clear	Clear	Clear	Clear	Clear	Clear	P11	—	—	—	—	—
54 CH/PSKIP-	Chap/Skip-	Chap/Skip-	Chap/Skip-	Chap/Skip-	Chap/Skip-	Chap/Skip-	Chap/Skip-	Chap/Skip-	P12	—	—	—	—	—
55 CH/PSKIP+	Chap/Skip+	Chap/Skip+	Chap/Skip+	Chap/Skip+	Chap/Skip+	Chap/Skip+	Chap/Skip+	Chap/Skip+	P13	—	—	—	—	—
56 TV VOL down	(TV Input)	(TV Input)	(TV Input)	(TV Input)	(TV Input)	(TV Input)	(TV Input)	(TV Input)	(TV Input)	(TV Input)	(TV Input)	(TV Input)	(TV Input)	(TV Input)
57 TV INPUT	(TV Input)	(TV Input)	(TV Input)	(TV Input)	(TV Input)	(TV Input)	(TV Input)	(TV Input)	(TV Input)	(TV Input)	(TV Input)	(TV Input)	(TV Input)	(TV Input)
58 TV MUTE	(TV Mute)	(TV Mute)	(TV Mute)	(TV Mute)	(TV Mute)	(TV Mute)	(TV Mute)	(TV Mute)	(TV Mute)	(TV Mute)	(TV Mute)	(TV Mute)	(TV Mute)	(TV Mute)
59 CH up	DISC+	DISC+	CH up	CH down	CH up	DISC+	DISC+	DISC+	CH up	CH up	CH up	CH up	CH up	CH up
60 CH down	DISC-	DISC-	CH down	CH down	CH down	DISC-	DISC-	DISC-	CH down	CH down	CH down	CH down	CH down	CH down

Initial Macro setup/初期登録マクロ

Key	Key Name	1	2	3	4~10
7	POWER on	K6	K35 TV	—	—
8	STANDBY	K7	—	—	—
9	VAUX	K8	—	—	—
10	PHONO	K9	—	—	—
11	TV	K10	K35 TAPE	—	—
12	D8S	K6	K12	—	—
13	TUNER	K6	K13	—	—
14	CD	K6	K14	K35 CD	—
15	MD	K6	K15	K35 MD	—
16	VCR1	K6	K16	K35 VCR1	—
17	VCR2	K6	K17	K35 VCR2	—
18	VCR3	K6	K18	K35 VCR3	—
19	LD	K6	K19	K35 LD	—
20	DVD	K6	K20	K35 DVD	—

*1: The key which has O is learning key.
 Oのキーは学習可能キー
 *2: The key which has O is Macro transmitting key.
 Oのキーはマクロ送信可能キー
 *3: The key which has O is for Device select.
 Oのキーはデバイス選択キー
 *4: The key which has D** is illuminated key.
 D**表記のあるキーは発光キー
 (O** : LED Assign/LED アサインを示す)

Parts List for Carbon Resistors

Value	1/4W Type Part No.	1/6W Type Part No.	Value	1/4W Type Part No.	1/6W Type Part No.
1.0 Ω	HJ35 3100	HF85 3100	10 kΩ	HF45 7100	HF45 7100
1.8 Ω	HJ35 3180	* HF85 3220	11 kΩ	HF45 7110	HF45 7110
2.2 Ω	HJ35 3220	HF85 3220	12 kΩ	HJ35 7120	HF85 7120
3.3 Ω	HJ35 3330	HF85 3330	13 kΩ	HF45 7130	HF45 7130
4.7 Ω	HJ35 3470	HF85 3470	15 kΩ	HF45 7150	HF45 7150
5.6 Ω	HJ35 3560	HF85 3560	18 kΩ	HF45 7180	HF45 7180
10 Ω	HF45 4100	HF45 4100	22 kΩ	HF45 7220	HF45 7220
15 Ω	HJ35 4150	HF85 4150	24 kΩ	HF45 7240	HF45 7240
22 Ω	HF45 4220	HF45 4220	27 kΩ	HJ35 7270	HF85 7270
27 Ω	HJ35 4270	HF85 4270	30 kΩ	HF45 7300	HF45 7300
33 Ω	HF45 4330	HF45 4330	33 kΩ	HF45 7330	HF45 7330
39 Ω	HJ35 4470	HF85 4390	36 kΩ	HF45 7360	HF45 7360
47 Ω	HF45 4470	HF45 4470	39 kΩ	HF45 7390	HF45 7390
56 Ω	HF45 4560	HF45 4560	47 kΩ	HF45 7470	HF45 7470
68 Ω	HF45 4680	HF45 4680	51 kΩ	HF45 7510	HF45 7510
75 Ω	HF45 4750	HF45 4750	56 kΩ	HF45 7560	HF45 7560
82 Ω	HF45 4820	HF45 4820	62 kΩ	HF45 7620	HF45 7620
91 Ω	HF45 4910	HF45 4910	68 kΩ	HF45 7680	HF45 7680
100 Ω	HF45 5100	HF45 5100	82 kΩ	HF45 7820	HF45 7820
110 Ω	HJ35 5110	HF85 5110	91 kΩ	HF45 7910	HF45 7910
120 Ω	HF45 5120	HF45 5120	100 kΩ	HF45 8100	HF45 8100
150 Ω	HF45 5150	HF45 5150	110 kΩ	HF45 8110	HF45 8110
160 Ω	HJ35 5160	* HF85 8120	120 kΩ	HF45 8120	HF45 8120
180 Ω	HF45 5180	HF45 5180	150 kΩ	HF45 8150	HF45 8150
200 Ω	HF45 5200	HF45 5200	180 kΩ	HF45 8180	HF45 8180
220 Ω	HF45 5220	HF45 5220	220 kΩ	HJ35 8220	HF85 8220
270 Ω	HF45 5270	HF45 5270	270 kΩ	HF45 8270	HF45 8270
330 Ω	HF45 5330	HF45 5330	300 kΩ	HF45 8300	HF45 8300
390 Ω	HF45 5390	HF45 5390	330 kΩ	HF45 8330	HF45 8330
430 Ω	HF45 5430	HF45 5430	390 kΩ	HJ35 8390	HF85 8390
470 Ω	HF45 5470	HF45 5470	470 kΩ	HF45 8470	HF45 8470
510 Ω	HF45 5510	HF45 5510	560 kΩ	HJ35 8560	HF85 8560
560 Ω	HF45 5560	HF45 5560	680 kΩ	HJ35 8680	HF85 8680
680 Ω	HF45 5680	HF45 5680	820 kΩ	HJ35 8820	HF85 8820
820 Ω	HF45 5820	HF45 5820	1.0 MΩ	HF45 9100	HF45 9100
910 Ω	HF45 5910	HF45 5910	1.2 MΩ	HJ35 9120	*
1.0 kΩ	HF45 6100	HF45 6100	1.5 MΩ	HJ35 9150	HF85 9150
1.2 kΩ	HF45 6120	HF45 6120	1.8 MΩ	HJ35 9180	HF85 9180
1.5 kΩ	HF45 6150	HF45 6150	2.2 MΩ	HJ35 9220	HF85 9220
1.8 kΩ	HF45 6180	HF45 6180	3.3 MΩ	HJ35 9330	HF85 9330
2.0 kΩ	HJ35 6200	HF85 6200	3.9 MΩ	HJ35 9390	*
2.2 kΩ	HF45 6220	HF45 6220	4.7 MΩ	HJ35 9470	HF85 9470
2.4 kΩ	HJ35 6240	HF85 6240			
2.7 kΩ	HF45 6270	HF45 6270			
3.0 kΩ	HF45 6300	HF45 6300			
3.3 kΩ	HF45 6330	HF45 6330			
3.6 kΩ	HJ35 6360	HF85 6360			
3.9 kΩ	HF45 6390	HF45 6390			
4.7 kΩ	HF45 6470	HF45 6470			
5.1 kΩ	HF45 6510	HF45 6510			
5.6 kΩ	HF45 6560	HF45 6560			
6.8 kΩ	HF45 6680	HF45 6680			
8.2 kΩ	HF45 6820	HF45 6820			
9.1 kΩ	HF45 6910	HF45 6910			

1/4W Type

HJ35

1/6W Type

HF85

DSP-AX1/RX-V1

YAMAHA